



# Fundamentals of Acoustics

**Michel Bruneau**

**Thomas Scelo**  
*translator and contributor*

**ISTE**

# Fundamentals of Acoustics

*This page intentionally left blank*

# Fundamentals of Acoustics

Michel Bruneau

Thomas Scelo  
Translator and Contributor

*Series Editor*  
*Société Française d'Acoustique*

ISTE

First published in France in 1998 by Editions Hermès entitled “Manuel d’acoustique fondamentale”

First published in Great Britain and the United States in 2006 by ISTE Ltd

Apart from any fair dealing for the purposes of research or private study, or criticism or review, as permitted under the Copyright, Designs and Patents Act 1988, this publication may only be reproduced, stored or transmitted, in any form or by any means, with the prior permission in writing of the publishers, or in the case of reprographic reproduction in accordance with the terms and licenses issued by the CLA. Enquiries concerning reproduction outside these terms should be sent to the publishers at the undermentioned address:

ISTE Ltd  
6 Fitzroy Square  
London W1T 5DX  
UK

ISTE USA  
4308 Patrice Road  
Newport Beach, CA 92663  
USA

[www.iste.co.uk](http://www.iste.co.uk)

© ISTE Ltd, 2006

© Editions Hermès, 1998

The rights of Michel Bruneau and Thomas Scelo to be identified as the authors of this work have been asserted by them in accordance with the Copyright, Designs and Patents Act 1988.

---

Library of Congress Cataloging-in-Publication Data

Bruneau, Michel.

[Manuel d'acoustique fondamentale. English]

Fundamentals of acoustics / Michel Bruneau; Thomas Scelo, translator and contributor.

p. cm.

Includes index.

ISBN-13: 978-1-905209-25-5

ISBN-10: 1-905209-25-8

1. Sound. 2. Fluids--Acoustic properties. 3. Sound--Transmission. I. Title.

QC225.15.B78 2006

534--dc22

2006014582

---

British Library Cataloguing-in-Publication Data

A CIP record for this book is available from the British Library

ISBN 10: 1-905209-25-8

ISBN 13: 978-1-905209-25-5

---

Printed and bound in Great Britain by Antony Rowe Ltd, Chippenham, Wiltshire.

# Table of Contents

<b>Preface</b> . . . . .	13
<b>Chapter 1. Equations of Motion in Non-dissipative Fluid</b> . . . . .	15
1.1. Introduction. . . . .	15
1.1.1. Basic elements . . . . .	15
1.1.2. Mechanisms of transmission . . . . .	16
1.1.3. Acoustic motion and driving motion . . . . .	17
1.1.4. Notion of frequency . . . . .	17
1.1.5. Acoustic amplitude and intensity. . . . .	18
1.1.6. Viscous and thermal phenomena . . . . .	19
1.2. Fundamental laws of propagation in non-dissipative fluids . . . . .	20
1.2.1. Basis of thermodynamics . . . . .	20
1.2.2. Lagrangian and Eulerian descriptions of fluid motion . . . . .	25
1.2.3. Expression of the fluid compressibility: mass conservation law . . . . .	27
1.2.4. Expression of the fundamental law of dynamics: Euler's equation. . . . .	29
1.2.5. Law of fluid behavior: law of conservation of thermomechanic energy . . . . .	30
1.2.6. Summary of the fundamental laws. . . . .	31
1.2.7. Equation of equilibrium of moments . . . . .	32
1.3. Equation of acoustic propagation . . . . .	33
1.3.1. Equation of propagation . . . . .	33
1.3.2. Linear acoustic approximation . . . . .	34
1.3.3. Velocity potential. . . . .	38
1.3.4. Problems at the boundaries . . . . .	40
1.4. Density of energy and energy flow, energy conservation law . . . . .	42
1.4.1. Complex representation in the Fourier domain . . . . .	42
1.4.2. Energy density in an "ideal" fluid . . . . .	43
1.4.3. Energy flow and acoustic intensity . . . . .	45
1.4.4. Energy conservation law. . . . .	48

**Chapter 1: Appendix. Some General Comments on Thermodynamics . . . . .** 50

    A.1. Thermodynamic equilibrium and equation of state . . . . . 50

    A.2. Digression on functions of multiple variables  
(study case of two variables) . . . . . 51

        A.2.1. Implicit functions . . . . . 51

        A.2.2. Total exact differential form . . . . . 53

**Chapter 2. Equations of Motion in Dissipative Fluid . . . . .** 55

    2.1. Introduction. . . . . 55

    2.2. Propagation in viscous fluid: Navier-Stokes equation . . . . . 56

        2.2.1. Deformation and strain tensor . . . . . 57

        2.2.2. Stress tensor . . . . . 62

        2.2.3. Expression of the fundamental law of dynamics . . . . . 64

    2.3. Heat propagation: Fourier equation. . . . . 70

    2.4. Molecular thermal relaxation . . . . . 72

        2.4.1. Nature of the phenomenon . . . . . 72

        2.4.2. Internal energy, energy of translation, of rotation and of  
vibration of molecules . . . . . 74

        2.4.3. Molecular relaxation: delay of molecular vibrations . . . . . 75

    2.5. Problems of linear acoustics in dissipative fluid at rest . . . . . 77

        2.5.1. Propagation equations in linear acoustics. . . . . 77

        2.5.2. Approach to determine the solutions . . . . . 81

        2.5.3. Approach of the solutions in presence of acoustic sources. . . . . 84

        2.5.4. Boundary conditions . . . . . 85

**Chapter 2: Appendix. Equations of continuity and equations at the  
thermomechanic discontinuities in continuous media. . . . .** 93

    A.1. Introduction . . . . . 93

        A.1.1. Material derivative of volume integrals . . . . . 93

        A.1.2. Generalization . . . . . 96

    A.2. Equations of continuity . . . . . 97

        A.2.1. Mass conservation equation . . . . . 97

        A.2.2. Equation of impulse continuity . . . . . 98

        A.2.3. Equation of entropy continuity. . . . . 99

        A.2.4. Equation of energy continuity . . . . . 99

    A.3. Equations at discontinuities in mechanics . . . . . 102

        A.3.1. Introduction . . . . . 102

        A.3.2. Application to the equation of impulse conservation. . . . . 103

        A.3.3. Other conditions at discontinuities . . . . . 106

    A.4. Examples of application of the equations at discontinuities  
in mechanics: interface conditions . . . . . 106

        A.4.1. Interface solid – viscous fluid . . . . . 107

        A.4.2. Interface between perfect fluids . . . . . 108

        A.4.3. Interface between two non-miscible fluids in motion. . . . . 109

<b>Chapter 3. Problems of Acoustics in Dissipative Fluids.</b>	111
3.1. Introduction.	111
3.2. Reflection of a harmonic wave from a rigid plane..	111
3.2.1. Reflection of an incident harmonic plane wave	111
3.2.2. Reflection of a harmonic acoustic wave	115
3.3. Spherical wave in infinite space: Green's function	118
3.3.1. Impulse spherical source.	118
3.3.2. Green's function in three-dimensional space.	121
3.4. Digression on two- and one-dimensional Green's functions in non-dissipative fluids	125
3.4.1. Two-dimensional Green's function	125
3.4.2. One-dimensional Green's function	128
3.5. Acoustic field in "small cavities" in harmonic regime	131
3.6. Harmonic motion of a fluid layer between a vibrating membrane and a rigid plate, application to the capillary slit.	136
3.7. Harmonic plane wave propagation in cylindrical tubes: propagation constants in "large" and "capillary" tubes.	141
3.8. Guided plane wave in dissipative fluid.	148
3.9. Cylindrical waveguide, system of distributed constants.	151
3.10. Introduction to the thermoacoustic engines (on the use of phenomena occurring in thermal boundary layers)	154
3.11. Introduction to acoustic gyrometry (on the use of the phenomena occurring in viscous boundary layers)	162
 <b>Chapter 4. Basic Solutions to the Equations of Linear Propagation in Cartesian Coordinates.</b>	 169
4.1. Introduction.	169
4.2. General solutions to the wave equation	173
4.2.1. Solutions for propagative waves	173
4.2.2. Solutions with separable variables	176
4.3. Reflection of acoustic waves on a locally reacting surface	178
4.3.1. Reflection of a harmonic plane wave	178
4.3.2. Reflection from a locally reacting surface in random incidence	183
4.3.3. Reflection of a harmonic spherical wave from a locally reacting plane surface	184
4.3.4. Acoustic field before a plane surface of impedance $Z$ under the load of a harmonic plane wave in normal incidence	185
4.4. Reflection and transmission at the interface between two different fluids.	187
4.4.1. Governing equations	187
4.4.2. The solutions	189
4.4.3. Solutions in harmonic regime.	190
4.4.4. The energy flux	192



4.5. Harmonic waves propagation in an infinite waveguide with rectangular cross-section. . . . .	193
4.5.1. The governing equations. . . . .	193
4.5.2. The solutions . . . . .	195
4.5.3. Propagating and evanescent waves . . . . .	197
4.5.4. Guided propagation in non-dissipative fluid . . . . .	200
4.6. Problems of discontinuity in waveguides . . . . .	206
4.6.1. Modal theory . . . . .	206
4.6.2. Plane wave fields in waveguide with section discontinuities . . . . .	207
4.7. Propagation in horns in non-dissipative fluids . . . . .	210
4.7.1. Equation of horns . . . . .	210
4.7.2. Solutions for infinite exponential horns. . . . .	214
<b>Chapter 4: Appendix. Eigenvalue Problems, Hilbert Space . . . . .</b>	<b>217</b>
A.1. Eigenvalue problems . . . . .	217
A.1.1. Properties of eigenfunctions and associated eigenvalues . . . . .	217
A.1.2. Eigenvalue problems in acoustics . . . . .	220
A.1.3. Degeneracy . . . . .	220
A.2. Hilbert space. . . . .	221
A.2.1. Hilbert functions and $L^2$ space . . . . .	221
A.2.2. Properties of Hilbert functions and complete discrete ortho-normal basis . . . . .	222
A.2.3. Continuous complete ortho-normal basis . . . . .	223
<b>Chapter 5. Basic Solutions to the Equations of Linear Propagation in Cylindrical and Spherical Coordinates . . . . .</b>	<b>227</b>
5.1. Basic solutions to the equations of linear propagation in cylindrical coordinates . . . . .	227
5.1.1. General solution to the wave equation . . . . .	227
5.1.2. Progressive cylindrical waves: radiation from an infinitely long cylinder in harmonic regime . . . . .	231
5.1.3. Diffraction of a plane wave by a cylinder characterized by a surface impedance. . . . .	236
5.1.4. Propagation of harmonic waves in cylindrical waveguides . . . . .	238
5.2. Basic solutions to the equations of linear propagation in spherical coordinates . . . . .	245
5.2.1. General solution of the wave equation . . . . .	245
5.2.2. Progressive spherical waves . . . . .	250
5.2.3. Diffraction of a plane wave by a rigid sphere . . . . .	258
5.2.4. The spherical cavity . . . . .	262
5.2.5. Digression on monopolar, dipolar and 2n-polar acoustic fields. . . . .	266

<b>Chapter 6. Integral Formalism in Linear Acoustics . . . . .</b>	<b>277</b>
6.1. Considered problems . . . . .	277
6.1.1. Problems . . . . .	277
6.1.2. Associated eigenvalues problem . . . . .	278
6.1.3. Elementary problem: Green's function in infinite space . . . . .	279
6.1.4. Green's function in finite space . . . . .	280
6.1.5. Reciprocity of the Green's function . . . . .	294
6.2. Integral formalism of boundary problems in linear acoustics . . . . .	296
6.2.1. Introduction . . . . .	296
6.2.2. Integral formalism . . . . .	297
6.2.3. On solving integral equations. . . . .	300
6.3. Examples of application . . . . .	309
6.3.1. Examples of application in the time domain . . . . .	309
6.3.2. Examples of application in the frequency domain. . . . .	318
<b>Chapter 7. Diffusion, Diffraction and Geometrical Approximation. . . . .</b>	<b>357</b>
7.1. Acoustic diffusion: examples . . . . .	357
7.1.1. Propagation in non-homogeneous media . . . . .	357
7.1.2. Diffusion on surface irregularities . . . . .	360
7.2. Acoustic diffraction by a screen. . . . .	362
7.2.1. Kirchhoff-Fresnel diffraction theory. . . . .	362
7.2.2. Fraunhofer's approximation. . . . .	364
7.2.3. Fresnel's approximation. . . . .	366
7.2.4. Fresnel's diffraction by a straight edge . . . . .	369
7.2.5. Diffraction of a plane wave by a semi-infinite rigid plane: introduction to Sommerfeld's theory. . . . .	371
7.2.6. Integral formalism for the problem of diffraction by a semi-infinite plane screen with a straight edge . . . . .	376
7.2.7. Geometric Theory of Diffraction of Keller (GTD) . . . . .	379
7.3. Acoustic propagation in non-homogeneous and non-dissipative media in motion, varying "slowly" in time and space: geometric approximation . . . . .	385
7.3.1. Introduction . . . . .	385
7.3.2. Fundamental equations . . . . .	386
7.3.3. Modes of perturbation . . . . .	388
7.3.4. Equations of rays . . . . .	392
7.3.5. Applications to simple cases . . . . .	397
7.3.6. Fermat's principle . . . . .	403
7.3.7. Equation of parabolic waves . . . . .	405
<b>Chapter 8. Introduction to Sound Radiation and Transparency of Walls . . . . .</b>	<b>409</b>
8.1. Waves in membranes and plates . . . . .	409
8.1.1. Longitudinal and quasi-longitudinal waves. . . . .	410
8.1.2. Transverse shear waves . . . . .	412

8.1.3. Flexural waves . . . . .	413
8.2. Governing equation for thin, plane, homogeneous and isotropic plate in transverse motion . . . . .	419
8.2.1. Equation of motion of membranes . . . . .	419
8.2.2. Thin, homogeneous and isotropic plates in pure bending . . . . .	420
8.2.3. Governing equations of thin plane walls . . . . .	424
8.3. Transparency of infinite thin, homogeneous and isotropic walls . . . . .	426
8.3.1. Transparency to an incident plane wave . . . . .	426
8.3.2. Digressions on the influence and nature of the acoustic field on both sides of the wall . . . . .	431
8.3.3. Transparency of a multilayered system: the double leaf system . . . . .	434
8.4. Transparency of finite thin, plane and homogeneous walls: modal theory . . . . .	438
8.4.1. Generally . . . . .	438
8.4.2. Modal theory of the transparency of finite plane walls . . . . .	439
8.4.3. Applications: rectangular plate and circular membrane . . . . .	444
8.5. Transparency of infinite thick, homogeneous and isotropic plates . . . . .	450
8.5.1. Introduction . . . . .	450
8.5.2. Reflection and transmission of waves at the interface fluid-solid. . . . .	450
8.5.3. Transparency of an infinite thick plate . . . . .	457
8.6. Complements in vibro-acoustics: the Statistical Energy Analysis (SEA) method . . . . .	461
8.6.1. Introduction . . . . .	461
8.6.2. The method . . . . .	461
8.6.3. Justifying approach. . . . .	463
<b>Chapter 9. Acoustics in Closed Spaces . . . . .</b>	<b>465</b>
9.1. Introduction. . . . .	465
9.2. Physics of acoustics in closed spaces: modal theory. . . . .	466
9.2.1. Introduction . . . . .	466
9.2.2. The problem of acoustics in closed spaces . . . . .	468
9.2.3. Expression of the acoustic pressure field in closed spaces. . . . .	471
9.2.4. Examples of problems and solutions . . . . .	477
9.3. Problems with high modal density: statistically quasi-uniform acoustic fields . . . . .	483
9.3.1. Distribution of the resonance frequencies of a rectangular cavity with perfectly rigid walls . . . . .	483
9.3.2. Steady state sound field at “high” frequencies. . . . .	487
9.3.3. Acoustic field in transient regime at high frequencies . . . . .	494
9.4. Statistical analysis of diffused fields . . . . .	497
9.4.1. Characteristics of a diffused field . . . . .	497
9.4.2. Energy conservation law in rooms . . . . .	498
9.4.3. Steady-state radiation from a punctual source . . . . .	500
9.4.4. Other expressions of the reverberation time . . . . .	502

9.4.5. Diffused sound fields. . . . .	504
9.5. Brief history of room acoustics . . . . .	508
<b>Chapter 10. Introduction to Non-linear Acoustics, Acoustics in Uniform Flow, and Aero-acoustics. . . . .</b>	<b>511</b>
10.1. Introduction to non-linear acoustics in fluids initially at rest . . . . .	511
10.1.1. Introduction . . . . .	511
10.1.2. Equations of non-linear acoustics: linearization method . . . . .	513
10.1.3. Equations of propagation in non-dissipative fluids in one dimension, Fubini's solution of the implicit equations. . . . .	529
10.1.4. Bürger's equation for plane waves in dissipative (visco-thermal) media . . . . .	536
10.2. Introduction to acoustics in fluids in subsonic uniform flows . . . . .	547
10.2.1. Doppler effect . . . . .	547
10.2.2. Equations of motion . . . . .	549
10.2.3. Integral equations of motion and Green's function in a uniform and constant flow . . . . .	551
10.2.4. Phase velocity and group velocity, energy transfer – case of the rigid-walled guides with constant cross-section in uniform flow . . . . .	556
10.2.5. Equation of dispersion and propagation modes: case of the rigid-walled guides with constant cross-section in uniform flow . . . . .	560
10.2.6. Reflection and refraction at the interface between two media in relative motion (at subsonic velocity) . . . . .	562
10.3. Introduction to aero-acoustics . . . . .	566
10.3.1. Introduction . . . . .	566
10.3.2. Reminder about linear equations of motion and fundamental sources . . . . .	566
10.3.3. Lighthill's equation . . . . .	568
10.3.4. Solutions to Lighthill's equation in media limited by rigid obstacles: Curle's solution . . . . .	570
10.3.5. Estimation of the acoustic power of quadrupolar turbulences . . . . .	574
10.3.6. Conclusion . . . . .	574
<b>Chapter 11. Methods in Electro-acoustics . . . . .</b>	<b>577</b>
11.1. Introduction . . . . .	577
11.2. The different types of conversion . . . . .	578
11.2.1. Electromagnetic conversion . . . . .	578
11.2.2. Piezoelectric conversion (example) . . . . .	583
11.2.3. Electrodynamic conversion . . . . .	588
11.2.4. Electrostatic conversion . . . . .	589
11.2.5. Other conversion techniques . . . . .	591
11.3. The linear mechanical systems with localized constants . . . . .	592
11.3.1. Fundamental elements and systems . . . . .	592
11.3.2. Electromechanical analogies . . . . .	596

- 11.3.3. Digression on the one-dimensional mechanical systems with distributed constants: longitudinal motion of a beam. . . . . 601
- 11.4. Linear acoustic systems with localized and distributed constants . . . . 604
  - 11.4.1. Linear acoustic systems with localized constants . . . . . 604
  - 11.4.2. Linear acoustic systems with distributed constants: the cylindrical waveguide . . . . . 611
- 11.5. Examples of application to electro-acoustic transducers. . . . . 613
  - 11.5.1. Electrodynamic transducer. . . . . 613
  - 11.5.2. The electrostatic microphone . . . . . 619
  - 11.5.3. Example of piezoelectric transducer . . . . . 624
- Chapter 11: Appendix** . . . . . 626
  - A.1 Reminder about linear electrical circuits with localized constants. . . . . 626
  - A.2 Generalization of the coupling equations . . . . . 628
- Bibliography** . . . . . 631
- Index** . . . . . 633

## Preface

The need for an English edition of these lectures has provided the original author, Michel Bruneau, with the opportunity to complete the text with the contribution of the translator, Thomas Scelo.

This book is intended for researchers, engineers, and, more generally, postgraduate readers in any subject pertaining to “physics” in the wider sense of the term. It aims to provide the basic knowledge necessary to study scientific and technical literature in the field of acoustics, while at the same time presenting the wider applications of interest in acoustic engineering. The design of the book is such that it should be reasonably easy to understand without the need to refer to other works. On the whole, the contents are restricted to acoustics in fluid media, and the methods presented are mainly of an analytical nature. Nevertheless, some other topics are developed succinctly, one example being that whereas numerical methods for resolution of integral equations and propagation in condensed matter are not covered, integral equations (and some associated complex but limiting expressions), notions of stress and strain, and propagation in thick solid walls are discussed briefly, which should prove to be a considerable help for the study of those fields not covered extensively in this book.

The main theme of the 11 chapters of the book is acoustic propagation in fluid media, dissipative or non-dissipative, homogeneous or non-homogeneous, infinite or limited, etc., the emphasis being on the “theoretical” formulation of problems treated, rather than on their practical aspects. From the very first chapter, the basic equations are presented in a general manner as they take into account the nonlinearities related to amplitudes and media, the mean-flow effects of the fluid and its inhomogeneities. However, the presentation is such that the factors that translate these effects are not developed in detail at the beginning of the book, thus allowing the reader to continue without being hindered by the need for in-depth understanding of all these factors from the outset. Thus, with the exception of

Chapter 10 which is given over to this problem and a few specific sections (diffusion on inhomogeneities, slowly varying media) to be found elsewhere in the book, developments are mainly concerned with linear problems, in homogeneous media which are initially at rest and most often dissipative.

These dissipative effects of the fluid, and more generally the effects related to viscosity, thermal conduction and molecular relaxation, are introduced in the fundamental equations of movement, the equations of propagation and the boundary conditions, starting in the second chapter, which is addressed entirely to this question. The richness and complexity of the phenomena resulting from the taking into account of these factors are illustrated in Chapter 3, in the form of 13 related “exercises”, all of which are concerned with the fundamental problems of acoustics. The text goes into greater depth than merely discussing the dissipative effects on acoustic pressure; it continues on to shear and entropic waves coupled with acoustic movement by viscosity and thermal conduction, and, more particularly, on the use that can be made of phenomena that develop in the associated boundary layers in the fields of thermoacoustics, acoustic grometry, guided waves and acoustic cavities, etc.

Following these three chapters there is coverage (Chapters 4 and 5) of fundamental solutions for differential equation systems for linear acoustics in homogenous dissipative fluid at rest: classic problems are both presented and solved in the three basic coordinate systems (Cartesian, cylindrical and spherical). At the end of Chapter 4, there is a digression on boundary-value problems, which are widely used in solving problems of acoustics in closed or unlimited domain.

The presentation continues (Chapter 6) with the integral formulation of problems of linear acoustics, a major part of which is devoted to the Green’s function (previously introduced in Chapters 3 and 5). Thus, Chapter 6 constitutes a turning point in the book insofar as the end of this chapter and through Chapters 7 to 9, this formulation is extensively used to present several important classic acoustics problems, namely: radiation, resonators, diffusion, diffraction, geometrical approximation (rays theory), transmission loss and structural/acoustic coupling, and closed domains (cavities and rooms).

Chapter 10 aims to provide the reader with a greater understanding of notions that are included in the basic equations presented in Chapters 1 and 2, those which concern non-linear acoustics, fluid with mean flow and aero-acoustics, and can therefore be studied directly after the first two chapters.

Finally, the last chapter is given over to modeling of the strong coupling in acoustics, emphasizing the coupling between electro-acoustic transducers and the acoustic field in their vicinity, as an application of part of the results presented earlier in the book.

## Chapter 1

# Equations of Motion in Non-dissipative Fluid

The objective of the two first chapters of this book is to present the fundamental equations of acoustics in fluids resulting from the thermodynamics of continuous media, stressing the fact that thermal and mechanical effects in compressible fluids are absolutely indissociable.

This chapter presents the fundamental phenomena and the partial differential equations of motion in non-dissipative fluids (viscosity and thermal conduction are introduced in Chapter 2). These equations are widely applicable as they can deal with non-linear motions and media, non-homogeneities, flows and various types of acoustic sources. Phenomena such as cavitation and chemical reactions induced by acoustic waves are not considered.

Chapter 2 completes the presentation by introducing the basic phenomenon of dissipation associated to viscosity, thermal conduction and even molecular relaxation.

### **1.1. Introduction**

The first paragraph presents, in no particular order, some fundamental notions of thermodynamics.

#### **1.1.1. *Basic elements***

The domain of physics acoustics is simply part of the fast science of thermomechanics of continuous media. To ensure acoustic transmission, three fundamental elements are required: one or several emitters or sources, one receiver



and a propagation medium. The principle of transmission is based on the existence of “particles” whose position at equilibrium can be modified. All displacements related to any types of excitation other than those related to the transmitted quantity are generally not considered (i.e. the motion associated to Brownian noise in gases).

### 1.1.2. Mechanisms of transmission

The waves can either be transverse or longitudinal (the displacement of the particle is respectively perpendicular or parallel to the direction of propagation). The fundamental mechanisms of wave transmission can be qualitatively simplified as follows. A particle B, adjacent to a particle A set in a time-dependent motion, is driven, with little delay, via the bonding forces; the particle A is then acting as a source for the particle B, which acts as a source for the adjacent particle C and so on (Figure 1.1).

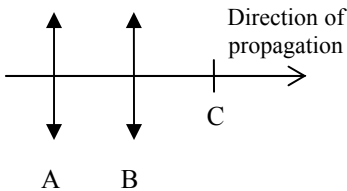

**Figure 1.1.** *Transverse wave*

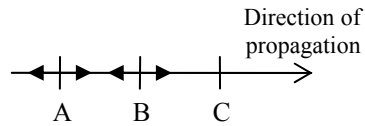

**Figure 1.2.** *Longitudinal wave*

The double bolt arrows represent the displacement of the particles.

In solids, acoustic waves are always composed of a longitudinal and a transverse component, for any given type of excitation. These phenomena depend on the type of bonds existing between the particles.

In liquids, the two types of wave always coexist even though the longitudinal vibrations are dominant.

In gases, the transverse vibrations are practically negligible even though their effects can still be observed when viscosity is considered, and particularly near walls limiting the considered space.

### 1.1.3. Acoustic motion and driving motion

The motion of a particle is not necessarily induced by an acoustic motion (audible sound or not). Generally, two motions are superposed: one is qualified as acoustic (A) and the other one is “anacoustic” and qualified as “driving” (E); therefore, if  $g$  defines an entity associated to the propagation phenomenon (pressure, displacement, velocity, temperature, entropy, density, etc.), it can be written as

$$g(x, t) = g_{(A)}(x, t) + g_{(E)}(x, t).$$

This field characteristic is also applicable to all sources. A fluid is said to be at rest if its driving velocity is null for all particles.

### 1.1.4. Notion of frequency

The notion of frequency is essential in acoustics; it is related to the repetition of a motion which is not necessarily sinusoidal (even if sinusoidal dependence is very important given its numerous characteristics). The sound-wave characteristics related to the frequency (in air) are given in Figure 1.3. According to the sound level, given on the dB scale (see definition in the forthcoming paragraph), the “areas” covered by music and voice are contained within the audible area.

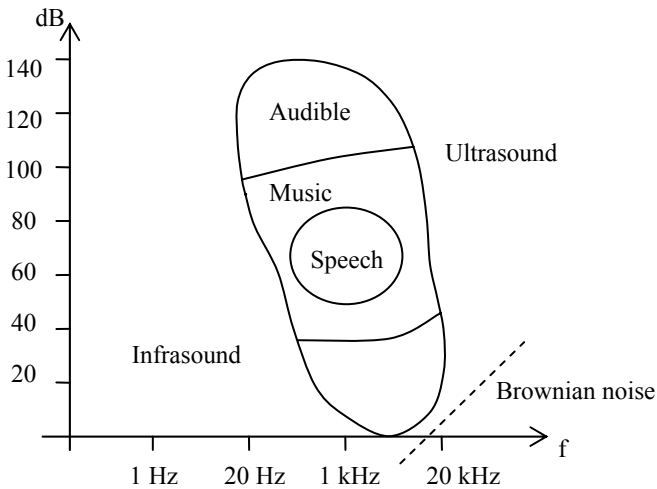

Figure 1.3. The sounds

### 1.1.5. Acoustic amplitude and intensity

The magnitude of an acoustic wave is usually expressed in decibels, which are unit based on the assumption that the ear approximately satisfies Weber-Fechner law, according to which the sense of audition is proportional to the logarithm of the intensity ( $I$ ) (the notion of intensity is described in detail at the end of this chapter). The level in decibel (dB) is then defined as follows:

$$L_{\text{dB}} = 10 \log_{10} I / I_r,$$

where  $I_r = 10^{-12} \text{ W/m}^2$  represents the intensity corresponding to the threshold of perception in the frequency domain where the ear sensitivity is maximum (approximately 1 kHz).

Assuming the intensity  $I$  is proportional to the square of the acoustic pressure (this point is discussed several times here), the level in dB can also be written as

$$L_{\text{dB}} = 20 \log_{10} p / p_r,$$

where  $p$  defines the magnitude of the pressure variation (called acoustic pressure) with respect to the static pressure (without acoustic perturbation) and where  $p_r = 2 \cdot 10^{-5} \text{ Pa}$  defines the value of this magnitude at the threshold of audibility around 1,000 Hz.

The origin 0 dB corresponds to the threshold of audibility; the threshold of pain, reached at about 120–140 dB, corresponds to an acoustic pressure equal to 20–200 Pa. The atmospheric pressure (static) in normal conditions is equal to  $1.013 \cdot 10^5 \text{ Pa}$  and is often written 1013 mbar or  $1.013 \cdot 10^6 \text{ } \mu\text{bar}$  (or baryes or  $\text{dyne/cm}^2$ ) or even 760 mm Hg.

The magnitude of an acoustic wave can also be given using other quantities, such as the particle displacement  $\xi$  or the particle velocity  $\vec{v}$ . A harmonic plane wave propagating in the air along an axis  $x$  under normal conditions of temperature (22°C) and of pressure can indifferently be represented by one of the following three variations of particle quantities

$$\begin{aligned} \xi &= \xi_0 \sin(\omega t - kx), \\ v &= \omega \xi_0 \sin(\omega t - kx), \\ p &= p_0 \sin(\omega t - kx), \end{aligned}$$

where  $p_0 = \rho_0 c_0 \omega \xi_0$ ,  $\rho_0$  defining the density of the fluid and  $c_0$  the speed of sound (these relations are demonstrated later on). For the air, in normal conditions of pressure and temperature,

$$\begin{aligned}c_0 &\cong 344.8 \text{ m s}^{-1}, \\ \rho_0 &\cong 1.2 \text{ kg m}^{-3}, \\ \rho_0 \cdot c_0 &\cong 400 \text{ kg m}^{-3} \text{ s}^{-1}\end{aligned}$$

At the threshold of audibility (0 dB), for a given frequency ( $N$ ) close to 1 kHz, the magnitudes are

$$\begin{aligned}p_0 &= 2 \cdot 10^{-5} \text{ Pa}, \\ v_0 &= \frac{p_0}{\rho_0 c_0} \cong 5 \cdot 10^{-8} \text{ ms}^{-1}, \\ \xi_0 &= \frac{v_0}{2\pi N} \cong 10^{-11} \text{ m}.\end{aligned}$$

It is worth noting that the magnitude  $\xi_0$  is 10 times smaller than the atomic radius of Bohr and only 10 times greater than the magnitude of the Brownian motion (which associated sound level is therefore equal to -20 dB, inaudible).

The magnitudes at the threshold of pain (at about 120 dB at 1 kHz) are

$$\begin{aligned}p_0 &= 20 \text{ Pa}, \\ v_0 &\cong 5 \cdot 10^{-2} \text{ ms}^{-1}, \\ \xi_0 &\cong 10^{-5} \text{ m}.\end{aligned}$$

These values are relevant as they justify the equations' linearization processes and therefore allow a first order expansion of the magnitude associated to acoustic motions.

### 1.1.6. *Viscous and thermal phenomena*

The mechanism of damping of a sound wave in “simple” media, homogeneous fluids that are not under any particular conditions (such as cavitation), results generally from two, sometimes three, processes related to viscosity, thermal conduction and molecular relaxation. These processes are introduced very briefly in this paragraph; they are not considered in this chapter, but are detailed in the next one.

When two adjacent layers of fluid are animated with different speeds, the viscosity generates reaction forces between these two layers that tend to oppose the displacements and are responsible for the damping of the waves. If case dissipation is negligible, these viscous phenomena are not considered.

When the pressure of a gas is modified, by forced variation of volume, the temperature of the gas varies in the same direction and sign as the pressure (Lechatelier's law). For an acoustic wave, regions of compression and depression are spatially adjacent; heat transfer from the "hot" region to the "cold" region is induced by the temperature difference between the two regions. The difference of temperature over half a wavelength and the phenomenon of diffusion of the heat wave are very slow and will therefore be neglected (even though they do occur); the phenomena will then be considered adiabatic as long as the dissipation of acoustic energy is not considered.

Finally, another damping phenomenon occurs in fluids: the delay of return to equilibrium due to the fact that the effect of the input excitation is not instantaneous. This phenomenon, called relaxation, occurs for physical, thermal and chemical equilibriums. The relaxation effect can be important, particularly in the air. As for viscosity and thermal conduction, this effect can also be neglected when dissipation is not important.

## **1.2. Fundamental laws of propagation in non-dissipative fluids**

### **1.2.1. Basis of thermodynamics**

"Sound" occurs when the medium presents dynamic perturbations that modify, at a given point and time, the pressure  $P$ , the density  $\rho_0$ , the temperature  $T$ , the entropy  $S$ , and the speed  $\bar{v}$  of the particles (only to mention the essentials). Relationships between those variables are obtained using the laws of thermomechanics in continuous media. These laws are presented in the following paragraphs for non-dissipative fluids and in the next chapter for dissipative fluids. Preliminarily, a reminder of the fundamental laws of thermodynamics is given; useful relationships in acoustics are numbered from (1.19) to (1.23). Complementary information on thermodynamics, believed to be useful, is given in the Appendix to this chapter.

A state of equilibrium of  $n$  moles of a pure fluid element is characterized by the relationship between its pressure  $P$ , its volume  $V$  (volume per unit of mass in acoustics), and its temperature  $T$ , in the form  $f(P, T, V) = 0$  (the law of perfect gases,  $PV - nRT = 0$ , for example, where  $n$  defines the number of moles and

$R = 8.32$  the constant of perfect gases). This thermodynamic state depends only on two, independent, thermodynamic variables.

The quantity of heat per unit of mass received by a fluid element  $dQ = T dS$  (where  $S$  represents the entropy) can then be expressed in various forms as a function of the pressure  $P$  and the volume per unit of mass  $V$  – reciprocal of the density  $\rho_0$  ( $V = 1/\rho_0$ )

$$T dS = C_p dT + h dP, \quad (1.1)$$

$$T dS = C_v dT + \ell dV, \quad (1.2)$$

where  $C_p$  and  $C_v$  are the heat capacities per unit of mass at respectively constant pressure and constant volume and where  $h$  and  $\ell$  represent the calorimetric coefficients defined by those two relations.

The entropy is a function of state; consequently,  $dS$  is an exact total differential, thus

$$\frac{C_p}{T} = \left( \frac{\partial S}{\partial T} \right)_P, \quad \frac{h}{T} = \left( \frac{\partial S}{\partial P} \right)_T \quad (1.3)$$

$$\frac{C_v}{T} = \left( \frac{\partial S}{\partial T} \right)_V, \quad \frac{\ell}{T} = \left( \frac{\partial S}{\partial V} \right)_T. \quad (1.4)$$

Applying Cauchy's conditions to the differential of the free energy  $F$  ( $dF = -SdT - PdV$ ) gives

$$\left( \frac{\partial P}{\partial T} \right)_V = \left( \frac{\partial S}{\partial V} \right)_T, \quad (1.5)$$

which, defining the increase of pressure per unit of temperature at constant density as  $\beta P = (\partial P / \partial T)_V$  and considering equation (1.4), gives

$$P \beta = \ell / T. \quad (1.6)$$

Similarly, Cauchy's conditions applied to the exact total differential of the enthalpy  $G$  ( $dG = -SdT + V dP$ ) gives

$$\left( \frac{\partial V}{\partial T} \right)_P = - \left( \frac{\partial S}{\partial P} \right)_T, \quad (1.7)$$

which, defining the increase of volume per unit of temperature at constant pressure as  $\alpha V = (\partial V / \partial T)_P$  and considering equation (1.3), gives

$$V\alpha = -h / T. \quad (1.8)$$

Reporting the relation

$$dV = (\partial V / \partial T)_P dT + (\partial V / \partial P)_T dP$$

Into

$$dS = (\partial S / \partial T)_V dT + (\partial S / \partial V)_T dV$$

leads to

$$\begin{aligned} dS &= [(\partial S / \partial T)_V + (\partial S / \partial V)_T (\partial V / \partial T)_P] dT + (\partial S / \partial V)_T (\partial V / \partial P)_T dP \\ \Rightarrow (\partial S / \partial T)_P &= (\partial S / \partial T)_V + (\partial S / \partial V)_T (\partial V / \partial T)_P. \end{aligned} \quad (1.9)$$

Finally, combining equations (1.3) to (1.8) yields

$$C_P - C_V = PVT\alpha\beta. \quad (1.10)$$

In the particular case where  $n$  moles of a perfect gas are contained in a volume  $V$  per unit of mass,

$$V\alpha = \frac{nR}{P} = \frac{V}{T} \quad \text{and} \quad P\beta = \frac{nR}{V} \quad \text{so} \quad C_P - C_V = nR. \quad (1.11)$$

Adopting the same approach as above and considering that

$$dT = (\partial T / \partial V)_P dV + (\partial T / \partial P)_V dP,$$

the quantity of heat per unit of mass  $dQ = TdS$  can be expressed in the forms

$$dQ = C_V dT + \ell dV = C_V (\partial T / \partial P)_V dP + [\ell + C_V (\partial T / \partial V)_P] dV \quad (1.12)$$

$$\text{or } dQ = C_P dT + h dV,$$

$$= C_P (\partial T / \partial V)_P dV + [h + C_P (\partial T / \partial P)_V] dP, \quad (1.13)$$

$$\text{or } dQ = \lambda dP + \mu dV. \quad (1.14)$$

Comparing equation (1.14) with equation (1.12) (considering, for example, an isochoric transformation followed by an isobaric transformation) directly gives

$$\lambda = C_V \left( \frac{\partial T}{\partial P} \right)_V = \frac{C_V}{P\beta} \quad \text{and} \quad \mu = C_P \left( \frac{\partial T}{\partial V} \right)_P = \frac{C_P}{V\alpha} = \frac{\rho C_P}{\alpha}. \quad (1.15)$$

Considering the fact that  $(\partial V / \partial P)_T (\partial T / \partial V)_P (\partial P / \partial T)_V = -1$  (directly obtained by eliminating the exact total differential of  $T(P, V)$  and also written as  $\alpha = \beta \chi_T P$ ) the ratio  $\lambda / \mu$  is defined by

$$\frac{\lambda}{\mu} = -\frac{1}{\gamma} \left( \frac{V}{\partial P} \right)_T = \frac{V \chi_T}{\gamma} = \frac{\chi_T}{\rho \gamma}, \quad (1.16)$$

where the coefficient of isothermal compressibility  $\chi_T$  is

$$\chi_T = -\frac{1}{V} \left( \frac{\partial V}{\partial P} \right)_T = \frac{1}{\rho} \left( \frac{\partial \rho}{\partial P} \right)_T, \quad (1.17)$$

and the ratio of specific heats is

$$\gamma = C_P / C_V.$$

For an adiabatic transformation  $dQ = \lambda dP + \mu dV = 0$ , the coefficient of adiabatic compressibility  $\chi_S$  defined by  $\chi_S V = -(\partial V / \partial P)_S$  can also be written as

$$-\chi_S V = (\partial V / \partial P)_S = -\frac{\lambda}{\mu} = -\frac{V \chi_T}{\gamma}.$$

Finally,

$$\chi_S = \chi_T / \gamma \quad (\text{Reech's formula}). \quad (1.18)$$

The variation of entropy per unit of mass is obtained from equations (1.14) and (1.15) as:

$$dS = \frac{C_V}{TP\beta} dP - \frac{C_P}{T\rho\alpha} d\rho. \quad (1.19)$$

Considering that  $\alpha = \beta \chi_T P$  and  $\chi_S = \chi_T / \gamma$ ,

$$dS = \frac{C_V}{TP\beta} \left[ dP - \frac{\gamma}{\rho \chi_T} d\rho \right] = \frac{C_V}{TP\beta} \left[ dP - \frac{1}{\rho \chi_S} d\rho \right]. \quad (1.20)$$



Moreover, equations (1.12) and (1.13) give

$$h + C_P(\partial T / \partial P)_V = C_V(\partial T / \partial P)_V \text{ and thus } h = -(C_P - C_V) / (P\beta).$$

Consequently, substituting the latter result into equation (1.13) yields

$$dS = \frac{C_P}{T} dT - \frac{C_P - C_V}{TP\beta} dP. \quad (1.21)$$

Substituting equation (1.10) and  $\gamma = \beta\chi_T P$  into equation (1.21) leads to

$$dS = \frac{C_P}{T} dT - \frac{P\beta}{\rho} \chi_T dP. \quad (1.22)$$

Lechatelier's law, according to which a gas temperature evolves linearly with its pressure, is there demonstrated, in particular for adiabatic transformations: writing  $dS=0$  in equation (1.22) brings proportionality between  $dT$  and  $dP$ , the proportionality coefficient  $TP\beta\chi_T / (\rho C_P)$  being positive.

The differential of the density  $d\rho = (\partial\rho / \partial P)_T dP + (\partial\rho / \partial T)_P dT$  can be expressed as a function of the coefficients of isothermal compressibility  $\chi_T$  and of thermal pressure variation  $\beta$  by writing that

$$\chi_T = -\frac{1}{V} \left( \frac{\partial V}{\partial P} \right)_T = \frac{1}{\rho} \left( \frac{\partial \rho}{\partial P} \right)_T \text{ and } P\beta\chi_T = \alpha = -\frac{1}{\rho} \left( \frac{\partial \rho}{\partial T} \right)_P.$$

Thus,

$$d\rho = \rho\chi_T [dP - P\beta dT]. \quad (1.23)$$

Note: according to equation (1.20), for an isotropic transformation ( $dS = 0$ ):

$$dP = \frac{\gamma}{\rho\chi_T} d\rho = \frac{\gamma}{\rho\chi_S} d\rho;$$

which, for a perfect gas, is

$$dP = \gamma \frac{RT}{M} d\rho = \gamma \frac{P}{\gamma} d\rho, \text{ where } \frac{dP}{P} + \gamma \frac{dV}{V} = 0,$$

leading, by integrating, to  $PV^\gamma = \text{cte} = P_0V_0^\gamma$  the law for a reversible adiabatic transformation.

Similarly, according to equation (1.23), for an isothermal transformation ( $dT = 0$ )

$$dP = \frac{1}{\rho\chi_T} d\rho. \quad (1.24)$$

### 1.2.2. Lagrangian and Eulerian descriptions of fluid motion

The parameters normally used to describe the nature and state of a fluid are those in the previous paragraph:  $\alpha, \beta, C_P, C_V, \gamma$ , etc. for the nature of the fluid and  $P, V$  or  $\rho, T, S$ , etc. for its state. However, the variables used to describe the dynamic perturbation of the gas are the variations of state functions, the differentials  $dP, dV$  or  $d\rho, dT, dS$ , etc. and the displacement (or velocity) of any point in the medium. The study of this motion, depending on time and location, requires the introduction of the notion of “particle” (or “elementary particle”): the set of all molecules contained in a volume chosen which is small enough to be associated to a given physical quantity (i.e. the velocity of a particle at the vicinity of a given point), but which is large enough for the hypothesis of continuous media to be valid (great number of molecules in the particle).

Finding the equations of motion requires the attention to be focused on a given particle. Therefore, two different, but equivalent, descriptions are possible: the Lagrangian description, in which the observer follows the evolution of a fluid element, differentiated from the others by its location  $X$  at a given time  $t_0$  (for example, its location can be defined as  $\chi(X, t)$  with  $\chi(X, t_0) = X$  and its velocity  $\dot{\chi} = \partial\chi(X, t)/\partial t$ ), and the Eulerian description, in which the observer is not interested in following the evolution of an individual fluid element over a period of time, but at a given location, defined by  $\bar{r}$  and considered fixed or at least with infinitesimal displacements (for the differential calculus). The Lagrangian description has the advantage of identifying the particles and giving their trajectories directly; however, it is not straightforward when studying the dynamic of a continuous fluid in motion. Therefore, Euler’s description, which uses variables that have an immediate meaning in the actual configuration, is most often used in acoustics. It is this description that will be used herein. It implies that the differential of an ordinary quantity  $q$  is written either as

$$\begin{aligned} dq &= q(\bar{r} + d\bar{r}, t + dt) - q(\bar{r}, t), \\ \text{or } dq &= q(\bar{r} + d\bar{r}, t + dt) - q(\bar{r}, t + dt) + q(\bar{r}, t + dt) - q(\bar{r}, t), \\ \text{or } dq &= \text{grad } q(\bar{r}, t + dt) d\bar{r} + \frac{\partial}{\partial t} q(\bar{r}, t) dt. \end{aligned}$$

The differential  $dq$  represents the material derivative (noted  $Dq$  in some works) if the observer follows the particle in infinitesimal motion with instantaneous velocity  $\vec{v}$ , that is  $d\vec{r} = \vec{v} dt$ . Then, considering the fact that  $q(t + dt)dt \approx q(t)dt$  by neglecting the 2<sup>nd</sup> order term  $(\partial q / \partial t)_0 dt dt$ ,

$$dq = \text{grad } q(\vec{r}, t) \vec{v} dt + \frac{\partial}{\partial t} q(\vec{r}, t) dt,$$

or, using the operator formalism,

$$\frac{d}{dt} = \vec{v} \text{grad} + \frac{\partial}{\partial t}. \tag{1.25}$$

The following brief comparison between those two descriptions highlights their respective practical implications. The superscripts (E) and (L) distinguish Euler’s from the Lagrangian approaches.

The instantaneous location  $\vec{r}$  of a particle is a function of  $\vec{r}_0$  and  $t$ , where  $\vec{r}_0$  is the location of the considered particle at  $t = t_0$  ( $\vec{r}_0$  is often representing the initial position).

Using Lagrangian variables, any quantity is expressed as a function of two variables  $\vec{r}_0$  and  $t$ . For example, the acceleration is represented by the function  $\vec{\Gamma}^{(L)}(\vec{r}_0, t)$ .

Using Eulerian variables, any quantity (the acceleration is used here as an example) is expressed as a function of the actual location  $\vec{r}$  and  $t$ , noted  $\vec{\Gamma}^{(E)}(\vec{r}, t)$ . This function can be expressed in such form that the expression of  $\vec{r}$  as a function of  $\vec{r}_0$  and  $t$  appears; it is then written as  $\vec{\Gamma}^{(E)}(\vec{r}(\vec{r}_0, t), t)$ , but still represents the same function  $\vec{\Gamma}^{(E)}(\vec{r}, t)$ .

These definitions result in the following relationships

$$\begin{aligned} \vec{\Gamma}^{(L)} &= \frac{\partial}{\partial t} \vec{v}^{(L)}(\vec{r}_0, t) = \frac{\partial^2}{\partial t^2} \vec{\chi}(\vec{r}_0, t), \\ \vec{\Gamma}^{(E)} &= \frac{d}{dt} \vec{v}^{(E)}(\vec{r}(\vec{r}_0, t), t) = \frac{\partial}{\partial t} \vec{v}^{(E)} + \vec{v}^{(E)} \text{grad } \vec{v}^{(E)}, \\ &= \frac{\partial}{\partial t} \vec{v}^{(E)} + \sum_j \frac{\partial}{\partial t} x_j(\vec{r}_0, t) \frac{\partial}{\partial x_j} \vec{v}^{(E)}, \end{aligned}$$

where  $\bar{v}^{(E)}(\bar{r}, t) = \frac{\partial}{\partial t} \bar{r}(\bar{r}_0, t)$ .

The physical quantity “acceleration” can either be expressed by  $\bar{\Gamma}^{(L)}(\bar{r}_0, t)$  or by  $\bar{\Gamma}^{(E)}(\bar{r}, t)$ .

### 1.2.3. Expression of the fluid compressibility: mass conservation law

A certain compressibility of the fluid is necessary to the propagation of an acoustic perturbation. It implies that the density  $\rho$ , being a function of the location  $\bar{r}$  and the time  $t$ , depends on spatial variations of the velocity field (which can intuitively be conceived), and eventually on the volume velocity of a local source acting on the fluid. This must be expressed by writing that a relation, easily obtained by using the mass conservation law, exists between the density  $\rho(\bar{r}, t)$  and the variations of the velocity field

$$\frac{d}{dt} \iiint_{D(t)} \rho dD = \iiint_{D(t)} \rho q(\bar{r}, t) dD, \quad (1.26)$$

The integral is calculated over a domain  $D(t)$  in motion, consequently containing the same particles, and the fluid input from a source  $q(\bar{r}, t)$  is expressed per unit of volume per unit of time ( $[q] = s^{-1}$ ). In the right hand side of equation (1.26), the factor  $\rho q$  denotes the mass of fluid introduced in  $D(t)$  per unit of volume and of time ( $[\rho \cdot q] = \text{kg} \cdot \text{m}^{-3} \cdot \text{s}^{-1}$ ). Without any source or outside its influence, the second term is null ( $q = 0$ ).

This mass conservation law can be equivalently expressed by considering a domain  $D_0$  fixed in space (the domain  $D_0$  can, for example, represent the previously defined domain  $D(t)$  at the initial time  $t = t_0$ ). The sum of the mass of fluid entering the domain  $D_0$  through the fixed surface  $S_0$ , per unit of time,

$$-\iint_{S_0} \rho \bar{v} d\bar{S}_0 \equiv -\iiint_{D_0} \text{div}(\rho \bar{v}) dD_0,$$

(where  $\bar{v}$  defines the particle velocity,  $d\bar{S}_0$  being parallel to the outward normal to the domain), and the mass of fluid introduced by an eventual source represented by

the factor  $\rho q$ , is equal to the increase of mass of fluid within the domain  $D_0$  per unit of time,

$$\frac{\partial}{\partial t} \iiint_{D_0} \rho dD_0 \equiv \iiint_{D_0} \frac{\partial \rho}{\partial t} dD_0,$$

Thus,

$$\iiint_{D_0} \left[ \frac{\partial \rho}{\partial t} + \operatorname{div}(\rho \vec{v}) \right] dD_0 = \iiint_{D_0} \rho q dD_0. \quad (1.27)$$

This equation must be valid for any domain  $D_0$ , implying that

$$\frac{\partial \rho}{\partial t} + \operatorname{div}(\rho \vec{v}) = \rho q. \quad (1.28)$$

Substituting equation (1.25) and the general relation:

$$\operatorname{div}(\rho \vec{v}) = \rho \operatorname{div} \vec{v} + \vec{v} \operatorname{grad} \rho,$$

leads to the following form of equation (1.27)

$$\frac{d\rho}{dt} + \rho \operatorname{div} \vec{v} = \rho q. \quad (1.29)$$

One can show that equation (1.26) can also be written as

$$\iiint_{D(t)} \left[ \frac{d\rho}{dt} + \rho \operatorname{div} \vec{v} \right] dD = \iiint_{D(t)} \rho q dD, \quad \forall D(t). \quad (1.30)$$

Equation (1.30) is equivalent to equation (1.29) since it is verified for any considered domain  $D(t)$ . Equations (1.26) to (1.30) are all equivalent and express the mass conservation law for a compressible fluid (incompressibility being defined by  $d\rho/dt = 0$ ).

**1.2.4. Expression of the fundamental law of dynamics: Euler's equation**

The fundamental equation of dynamics is the equation of equilibrium between forces applied to the particle, inertial forces, forces due to the pressure difference between one side of the particle and the other side, and viscosity-related forces, shear viscosity as well as volume viscosity (for polyatomic molecules). Neglecting in this chapter the effect related to the viscosity (non-dissipative fluid), the equation of equilibrium of the forces is obtained by writing that, projected onto the x-axis (for example) the resultant of all external forces applied to the fluid element  $dx dy dz$  (the particle), sum of all the forces due to pressure difference (Figure 1.4)

$$[P(x) - P(x + dx)] dy dz = - \frac{\partial P}{\partial x} dx dy dz$$

and of those introduced by some eventual acoustic sources (characterized by the external force per unit of mass  $\vec{F}$ )  $\rho \vec{F} dx dy dz$ , is equal to the inertial force of the considered mass of fluid

$$\rho dx dy dz \frac{dv_x}{dt}.$$

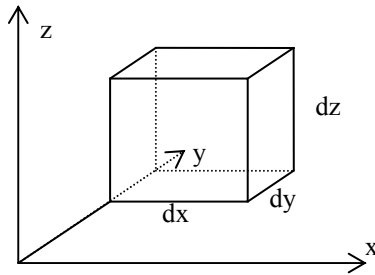

**Figure 1.4.** Fluid particle

Similar equations can be obtained by projection onto the y- and z-axes. A vectorial expression of the equilibrium of the forces is then obtained and is called Euler's equation

$$\rho \frac{d\vec{v}}{dt} = -\text{grad } P + \rho \vec{F}, \tag{1.31}$$

$$\text{or } \rho \left( \frac{\partial \vec{v}}{\partial t} + \vec{v} \text{grad } \vec{v} \right) = -\text{grad } P + \rho \vec{F}, \tag{1.32}$$

where the function  $\vec{F}$  is replaced by zero outside the zones of influence of the eventual sources.

The generalization to a finite domain (D), limited by a surface (S), is obtained by integration, according to the relation  $\iiint_D \text{grad PdD} = \iint_S \text{Pd}\vec{S}$

$$\iiint_D \rho \frac{d\vec{v}}{dt} dD = - \iint_S \text{Pd}\vec{S} + \iiint_D \rho \vec{F} dD . \quad (1.33)$$

### 1.2.5. Law of fluid behavior: law of conservation of thermomechanic energy

The laws governing the state of a particle are based on the thermomechanics in continuous media and must include not only the purely mechanical and macroscopic energy (kinetic, potential and dissipative), but also the thermal energy since it is assumed that the considered “system” (particle) contains a large number of molecules. Part of the mechanical energy (acoustic energy) is dissipated into heat by viscous damping and will therefore not be considered in this chapter as viscosity is only introduced in Chapter 2.

To the variation of pressure (considered in Euler’s equation) is associated a variation of temperature (see comments following equation (1.22)) between the considered particle and the surrounding particles. This difference generates a heat transfer expressed in terms of the heat quantity  $dQ$  received by the considered particle. The variation  $dQ$ , depending on the path used between the initial state and the final state, does not have the same properties as the total exact differential. This is not the case for the variation of entropy  $dS$  associated to the heat  $dQ$  by  $dQ = T dS$  where  $T$  represents the particle temperature. (This relationship presents an analogy with the expression of the elementary work received by the particle  $dW = (-P)dV$  in which the pressure variation is the cause and the variation of volume is the effect.) The effects of the heat flow established within the fluid under the acoustic motion appear to be dissipative and of similar order of magnitude as the viscosity effects (thermal or purely acoustic). They are consequently ignored in this chapter. With only heat input from an eventual exterior heat source being considered, the source is then characterized by the heat quantity  $h$ , introduced per unit of mass and time. If  $S$  is the entropy per unit of mass, the relation governing the above statements is then

$$T dS = h dt. \quad (1.34)$$

Without any thermal source  $h(\bar{r}, t)$  at the location  $\bar{r}$  and time  $t$  considered, this equation expresses the adiabatic property of the transformations ( $dS=0$ ). This adiabatic can be expressed by taking  $dS=0$  null in equations (1.20), as

$$dP = \frac{\gamma}{\rho\chi_T} d\rho = \frac{1}{\rho\chi_S} d\rho. \quad (1.35)$$

In acoustics, equation (1.35) is more often written in the form

$$dP = c^2 d\rho \quad (1.36)$$

with  $c^2 = \frac{\gamma}{\rho\chi_T} = \frac{1}{\rho\chi_S}$ .

From a mechanical point of view, this constitutes a behavior law relating the variation of volume to a stress called pressure.

Note: the thermodynamic quantity  $c$  is defined as a velocity; it is the velocity of homogeneous acoustic plane waves.

### 1.2.6. Summary of the fundamental laws

In addition to the particle velocity  $\bar{v}$  (kinetic variable), four thermodynamic variables ( $P, \rho$  or  $V, T, S$ ) and their associated variations ( $dP, d\rho$  or  $dV, dT, dS$ ) have been mentioned in the previous paragraphs, but according to the assumption made previously, only three of them ( $P, \rho, S$ ) are required to describe the acoustic motion since the variation of temperature  $dT$  intervenes only in the thermal conduction factor, which has not been covered in this chapter. Besides, there are only three fundamental equations available to describe the mass conservation law (expressing the compressibility of the fluid, section 1.2.3), the fundamental law of dynamic (vectorial form, section 1.2.4) and the conservation of thermomechanic energy (in analogy with a behavior law, section 1.2.5). Within the hypothesis of adiabatic motion, the variable  $dS$  (and  $dT$ ) disappears and the problem presents the same number of equations and variables. However, in the presence of a heat source, the quantity  $dS$  (equation (1.34)) and, when dissipation is considered, the variation of temperature  $dT$  appears in the conduction coefficient, then introduced in the equation (1.34).

It is then necessary to introduce the notion of bivariance of the considered fluid, according to which the thermodynamic state of the fluid is a function of only two variables of state, chosen from among the four already introduced ( $P, \rho, T$  and  $S$ ). Thus, the differentials of those variables, related to the acoustic motion, can be



expressed as functions of the two others, reducing the number of unknowns to three, including a vectorial one (the particle velocity). For example, to eliminate the elementary variables  $dp$  and  $dS$  and therefore conserving  $dP$  and  $dT$ , all that is necessary is to combine equations (1.22) and (1.23).

### 1.2.7. Equation of equilibrium of moments

According to the fundamental principles of mechanics, it is necessary to write the equations of equilibrium of forces and moments. The object of this paragraph is to show that these equations imply the fundamental principles of mechanics, which consequently does not offer additional information.

The moment (which must be null) of all the forces with respect to one point is

$$\iiint_D \overline{OM} \wedge \rho \left( \frac{d\vec{v}}{dt} - \vec{F} \right) dD + \iint_S \overline{OM} \wedge P d\vec{S} = \vec{0}, \quad (1.37)$$

or, by projection onto  $\vec{Ox}$ ,

$$\iiint_D \rho \left[ x_2 \left( \frac{dv_3}{dt} - F_3 \right) - x_3 \left( \frac{dv_2}{dt} - F_2 \right) \right] dD + \iint_S P [x_2 n_3 - x_3 n_2] dS = 0, \quad (1.38)$$

where  $n_1, n_2, n_3$  denote the cosines directing  $d\vec{S}$ , and  $(D)$  is a closed domain limited by the surface  $(S)$ .

Defining the vector  $\vec{A}$  of components  $(0, 0, px_2)$ , the quantity  $px_2 n_3 dS$  can be written as  $\vec{A} \cdot d\vec{S}$  and the theorem of divergence gives

$$\begin{aligned} \iint_S \vec{A} \cdot d\vec{S} &= \iiint_D \text{div } \vec{A} dD, \\ \text{or, } \iint_S P x_2 n_3 dS &= \iiint_D \frac{\partial}{\partial x_3} (P x_2) dD = \iiint_D x_2 \frac{\partial P}{\partial x_3} dD. \end{aligned}$$

Consequently, the integration of equation (1.38) over the surfaces becomes

$$\iint_S P [x_2 n_3 - x_3 n_2] dS = \iiint_D \left( x_2 \frac{\partial P}{\partial x_3} - x_3 \frac{\partial P}{\partial x_2} \right) dD.$$

It is the projection of the volume integral  $\iiint_D \overrightarrow{OM} \wedge \text{grad } P dD$  onto the x-axis. Equation (1.37) can finally be written as

$$\iiint_D \overrightarrow{OM} \wedge \left[ \rho \left( \frac{d\vec{v}}{dt} - \vec{F} \right) + \text{grad } P \right] dD = \vec{0}, \quad (1.39)$$

which is satisfied since Euler's equation sets the term in brackets equal to zero.

### 1.3. Equation of acoustic propagation

#### 1.3.1. Equation of propagation

The general solution to the system of equations of motion in non-dissipative fluid is generally obtained by solving this system for the pressure, the other parameters being obtained by substitution of the pressure into the considered system. This method is presented here.

Substituting equation (1.20) into (1.34) and, considering the relations  $\alpha = \beta \chi_T P$  and  $C_p = \gamma C_v$ , leads to

$$\frac{1}{\rho} \frac{d\rho}{dt} = \frac{\chi_T}{\gamma} \frac{dP}{dt} - \frac{\alpha}{C_p} h. \quad (1.40)$$

Applying the operator "div" to Euler's equation (1.31) and "d/dt" to the mass conservation law (1.29), after having divided both by the factor  $\rho$ , leads to the two following equations

$$\text{div} \left[ \frac{d}{dt} \vec{v} + \frac{1}{\rho} \text{grad } P - \vec{F} \right] = 0, \quad (1.41)$$

$$\text{and } \frac{d}{dt} \left[ \left( \frac{1}{\rho} \frac{d\rho}{dt} \right) + \text{div } \vec{v} - q \right] = 0. \quad (1.42)$$

Substituting equation (1.40) into (1.42), then subtracting equation (1.42) from equation (1.41), eliminates the variables  $\rho$  and  $\vec{v}$ , and finally leads to the equation of propagation for the pressure

$$\text{div} \left[ \frac{1}{\rho} \text{grad } P \right] - \frac{d}{dt} \left( \frac{\chi_T}{\gamma} \frac{dP}{dt} \right) = \text{div } \vec{F} - \frac{dq}{dt} - \frac{d}{dt} \left( \frac{\alpha h}{C_p} \right), \quad (1.43)$$

$$\text{or } \text{grad} \left( \frac{1}{\rho} \right) \text{grad } P + \frac{1}{\rho} \Delta P - \frac{d}{dt} \left( \frac{\chi_T}{\gamma} \frac{dP}{dt} \right) = \text{div } \vec{F} - \frac{dq}{dt} - \frac{d}{dt} \left( \frac{\alpha h}{C_p} \right). \quad (1.44)$$

Within the often-used hypothesis of a (quasi-) homogeneous fluid which dynamic characteristics are (quasi-) independent of the time, and where the factors  $\text{grad}(1/\rho)$ ,  $\frac{d}{dt}\left(\frac{\chi_T}{\gamma}\right)$ , and  $\frac{d}{dt}\left(\frac{\alpha h}{C_p}\right)$  are small enough to neglect the terms where they appear; equation (1.44) becomes

$$\Delta P - \frac{1}{c^2} \frac{d^2 P}{dt^2} = \rho \left[ \text{div } \vec{F} - \frac{dq}{dt} - \frac{\alpha}{C_p} \frac{dh}{dt} \right], \quad (1.45)$$

where (equation (1.36))  $c^2 = \gamma / (\rho \chi_T) = 1 / (\rho \chi_S)$ .

$$\text{It is an equation of the kind } P = -f, \quad (1.46)$$

where the D'Alembertian operator is the operator of propagation  $\left(\Delta - \frac{1}{c^2} \frac{d^2}{dt^2}\right)$  applied to the pressure field, and where the second term  $(-f)$ , representing the effects of the source (described by the force  $\vec{F}$  applied to the media, the volume velocity source  $q$ , the heat source  $h$ ), is assumed to be known.

### 1.3.2. Linear acoustic approximation

The previous equations are all non-linear since all terms contain products of differential elements. This can be verified, for example in the case of equation (1.14) of the differential of the mass entropy  $TdS = \lambda dP + \mu dV$ , whose integral is simple when applied to perfect gases ( $PV = nRT$ ). Indeed, equations (1.15) lead to

$$\lambda = C_V \left( \frac{\partial T}{\partial P} \right)_V = C_V \frac{T}{P}, \quad (1.47)$$

$$\mu = C_P \left( \frac{\partial T}{\partial V} \right)_P = C_P \frac{T}{V}, \quad (1.48)$$

$$\text{thus } dS = C_V \frac{dP}{P} + C_P \frac{dV}{V} = C_V \left( \frac{dP}{P} + \gamma \frac{dV}{V} \right) = C_V \left( \frac{dP}{P} - \gamma \frac{d\rho}{\rho} \right) \quad (1.49)$$

or, integrating between the "current" state and the initial state of index zero (the parameters  $C_V$  and  $\gamma$  being considered constant within this interval), to

$$\frac{S - S_0}{C_V} = \ln \left[ \frac{P}{P_0} \left( \frac{\rho}{\rho_0} \right)^{-\gamma} \right], \quad (1.50)$$

$$\text{or } \frac{P}{P_0} = \left( \frac{\rho}{\rho_0} \right)^\gamma \exp \left( \frac{S - S_0}{C_V} \right) \quad (1.51)$$

which is obviously not linear.

By replacing the equation (1.36) by  $c_0^2 = \gamma / (\rho_0 \chi_T)$  (or  $c_0^2 = \gamma P_0 / \rho_0$  for a perfect gas), equation (1.51) can be expanded into Taylor's series, estimated at the initial state

$$P - P_0 = c_0^2 (\rho - \rho_0) + \frac{\gamma - 1}{2\rho_0} c_0^2 (\rho - \rho_0)^2 + \dots + c_0^2 \frac{\rho_0}{\gamma C_V} (S - S_0) + \dots \quad (1.52)$$

If the parameters  $P_0, \rho_0, S_0$  represent the state of the fluid at rest, meaning here the state of the fluid without acoustic perturbation, the quantities  $(P - P_0), (\rho - \rho_0), (S - S_0)$  represent the variations, due to the acoustic perturbation, at any given point and time from the state at rest. According to the first comments in this chapter, these variations are generally small, so that the Taylor's expansion can be, in most situations, limited to the first order, transforming a non-linear law into a linear one. Denoting

$$p = P - P_0, \quad \rho' = \rho - \rho_0 \quad \text{and} \quad s = S - S_0, \quad (1.53)$$

the linearized equation (1.52) is

$$p \approx c_0^2 \left[ \rho' + \frac{\rho_0}{\gamma C_V} s \right]. \quad (1.54)$$

This is equivalent to replacing equation (1.52), written as

$$dP = \frac{\gamma P}{\rho} d\rho + \frac{P}{C_V} dS = c^2 \left[ d\rho + \frac{\rho}{\gamma C_V} dS \right],$$

by the approximated equation

$$dP \approx \frac{\gamma P_0}{\rho_0} d\rho + \frac{P_0}{C_V} dS = c_0^2 \left[ d\rho + \frac{\rho_0}{\gamma C_V} dS \right],$$

where  $c_0^2 = \gamma P_0 / \rho_0$  (which is very often used) which, integrated between the state at rest (referential state)  $P_0, \rho_0, S_0$  and the current state  $P, \rho, S$ , leads directly to equation (1.54).

It is convenient at this stage to note that the two elementary independent variables  $\rho'$  and  $s$  are both considered as infinitesimal and of the first order, but in practice are such that

$$\frac{\rho_0}{\gamma C_V} s \ll \rho', \text{ and hereinafter } p \approx c_0^2 \rho', \tag{1.55}$$

which is equivalent to writing  $s \approx 0$ . This result translates the adiabaticity of the considered phenomena without sources and when thermal conduction is neglected according to the conclusion of section 1.2.5.

The linear versions of the fundamental equations of motion are very convenient since their solutions are easier to find. Moreover, the approximation of linear acoustics holds in many cases. Thus, using the notations  $p = P - P_0, \rho' = \rho - \rho_0, s = S - S_0$ , and writing the particular velocity as a sum of a “driving” velocity  $\vec{v}_E$  and a velocity related to an acoustic perturbation  $\vec{v}_a$  ( $\vec{v} = \vec{v}_E + \vec{v}_a$ ), Euler’s equation (1.31),  $\rho d\vec{v} / dt = -\text{grad } P + \rho \vec{F}$ , becomes

$$(\rho_0 + \rho') \left[ \frac{\partial}{\partial t} + (\vec{v}_E + \vec{v}_a) \text{grad} \right] (\vec{v}_E + \vec{v}_a) = -\text{grad} (P_0 + p) + (\rho_0 + \rho') \vec{F}.$$

That is, admitting the often verified hypothesis that the functions  $\text{grad} P$  and  $\rho_0 \partial \vec{v}_E / \partial t$  are negligible, and conserving only the 1<sup>st</sup> order terms of small quantities  $p, \rho'$  and  $\vec{v}_a$ ,

$$\rho_0 \vec{v}_E \text{grad} \vec{v}_E + \rho_0 \left( \frac{\partial}{\partial t} + \vec{v}_E \text{grad} \right) \vec{v}_a \approx -\text{grad} p + \rho_0 \vec{F}.$$

which finally, if the fluid without perturbation is at rest ( $\vec{v}_E = \vec{0}, \vec{v}_a = \vec{v}$ ), leads to

$$\rho_0 \frac{\partial \vec{v}}{\partial t} \simeq -\text{grad} p + \rho_0 \vec{F}. \tag{1.56}$$

Under the same hypotheses, the mass conservation law (1.28) or (1.29) immediately becomes

$$\frac{\partial \rho'}{\partial t} + \rho_0 \text{div} \vec{v} = \rho_0 q. \tag{1.57}$$

Finally, equation (1.40), which expresses the adiabatic character of the transformation without source,

$$\frac{d\rho}{\rho} = \frac{\chi_T}{\gamma} dP - \frac{\alpha}{C_P} h dt \quad (1.58)$$

can be approximated, writing that  $\frac{d\rho_0}{dt} = \frac{dP_0}{dt} = 0$ , to

$$\frac{1}{\rho_0} d\rho' \simeq \frac{\chi_T}{\gamma} dp - \frac{\alpha}{C_P} h dt \left( \text{or } \frac{\partial \rho'}{\partial t} = \frac{1}{c_0^2} \frac{\partial p}{\partial t} - \frac{\alpha \rho_0}{C_P} h \right). \quad (1.59)$$

This is, by integrating from the state at rest  $(p_0, \rho_0)$  at the time  $t_0$  to the actual state  $(P_0 + p, \rho_0 + \rho')$ , at the time  $t$ , and by ignoring the eventual variations of the parameters  $\chi_T, \gamma, \alpha, C_P$  within the interval of integration

$$\begin{aligned} \frac{1}{\rho_0} \rho' &= \frac{\chi_T}{\gamma} p - \frac{\alpha}{C_P} \int_{t_0}^t h dt, \\ \text{or } p &\simeq c_0^2 \left[ \rho' + \frac{\alpha \rho_0}{C_P} \int_{t_0}^t h dt \right] \text{ where } c_0^2 = \frac{\gamma}{\rho_0 \chi_T}. \end{aligned} \quad (1.60)$$

This result can also be obtained by directly integrating equation (1.58)

$$\ln(\rho/\rho_0) = \frac{\chi_T}{\gamma} (P - P_0) - \frac{\alpha}{C_P} \int_{t_0}^t h dt,$$

and then expanding this equation to the first order.

The set of equations (1.56), (1.57) and (1.60) constitutes the system governing the acoustic propagation in non-dissipative homogeneous fluid initially at rest and within the linear acoustics approximation. The substitution of equation (1.60) into (1.57), then the sum (considering a change of sign) of the time derivative of the latter and of the divergence of equation (1.56), leads to the linear form of the equation of acoustic propagation (1.45)

$$\Delta p - \frac{1}{c_0^2} \frac{\partial^2}{\partial t^2} p = \rho_0 \left[ \text{div } \vec{F} - \frac{\partial q}{\partial t} - \frac{\alpha}{C_P} \frac{\partial h}{\partial t} \right], \quad (1.61)$$

where  $p$  represents the acoustic pressure, the variation of pressure with respect to the average static pressure  $P_0$ .

The particle velocity  $\vec{v}$  (more precisely, its derivative with respect to the time) can be derived from the general solution by simply using Euler's equation (1.56), differentiating (without source) and taking  $\rho' = p/c_0^2$ . The acoustic field is then defined by the set of variables  $(p, \vec{v})$ .

### 1.3.3. Velocity potential

Assuming the conditions of regularity are fulfilled, any vector field can be uniquely decomposed into the sum of an irrotational field  $\vec{v}_\ell$  ( $\text{rot } \vec{v}_\ell = 0, \text{div } \vec{v}_\ell \neq 0$ ) and a non-divergent (or vortical) field  $\vec{v}_v$  ( $\text{div } \vec{v}_v = 0, \text{rot } \vec{v}_v \neq 0$ ):

$$\vec{v} = \vec{v}_\ell + \vec{v}_v. \quad (1.62)$$

*It has been shown that according to these operators' properties ( $\text{rot } \text{grad} \equiv 0$  and  $\text{div } \text{rot} \equiv 0$ ), there exists a scalar function  $\phi(\vec{r}, t)$  called "velocity potential" such that:*

$$\vec{v}_\ell = \text{grad } \phi \quad (1.63)$$

*and a vectorial function  $\vec{\psi}(\vec{r}, t)$  called "vortical potential" such that:*

$$\vec{v}_v = \text{rot } \vec{\psi}. \quad (1.64)$$

*The particle velocity can finally be written as*

$$\vec{v} = \text{grad } \phi + \text{rot } \vec{\psi}. \quad (1.65)$$

The choice of the function  $\vec{\psi}$  is partly arbitrary since the set of functions  $(v_x, v_y, v_z)$  is related to the set  $(\phi, \psi_x, \psi_y, \psi_z)$ . Therefore, a constraint can be imposed on the vectorial function  $\vec{\psi}$  without modifying the expression of  $\vec{v}$ . This choice, called the choice of gauge, is usually in the form  $\text{div } \vec{\psi} = 0$  in order to simplify the search for solutions to problems where the vortical component  $\vec{v}_v$  is not null.

Here  $\vec{v}_v = \vec{0}$  since the rotational of Euler's equation, outside the influence of any source, gives

$$\text{rot} \frac{d\vec{v}}{dt} = \vec{0}, \quad \forall(\vec{r}, t) \text{ or } \text{rot} \vec{v} = \vec{0},$$

Consequently

$$\vec{v} = \text{grad} \varphi = \vec{v}_\ell. \quad (1.66)$$

Substituting this result into the linearized Euler's equation (without source) yields the relationship between  $p$  and  $\varphi$  :

$$\rho_0 \frac{\partial}{\partial t} \text{grad} \varphi = -\text{grad} p,$$

that is, for  $\rho_0$  independent of the point  $(\vec{r}, t)$

$$\text{grad} \left[ p + \rho_0 \frac{\partial \varphi}{\partial t} \right] = \vec{0}, \quad \forall(\vec{r}, t),$$

$$\text{from which } p = -\rho_0 \frac{\partial \varphi}{\partial t}. \quad (1.67)$$

Omitting the simple operator  $(-\rho_0 \partial/\partial t)$  leads to the observation that pressure variation and velocity potential satisfy the same equation of propagation, within the approximation of linear acoustic, in homogeneous and non-dissipative fluids. For this reason, some authors prefer to use the velocity potential.

It is relatively easy to obtain the equation of propagation satisfied by the particle velocity by eliminating the variables  $P$  and  $\rho$ , respectively  $p$  and  $\rho'$ , in the system of non-linear equations (1.29), (1.31), (1.40), respectively in the system of linear equations (1.56), (1.57) and (1.60). It is then necessary to apply the gradient operator to the equation of conservation of mass and  $d/dt$  (or  $\partial/\partial t$ ) to Euler's equation and process as in the case of the equation of propagation of the pressure. The resulting equation is

$$\text{grad} \text{div} \vec{v} - \frac{1}{c^2} \frac{d^2 \vec{v}}{dt^2} = -\frac{1}{c^2} \frac{d\vec{F}}{dt} + \text{grad} q + \frac{\alpha}{C_p} \text{grad} h. \quad (1.68)$$



The linear approximation of equation (1.68) is obtained by replacing  $c$  by  $c_0$  and  $d/dt$  by  $\partial/\partial t$ .

Given the vector equality  $\text{grad div} = \Delta + \text{rot rot}$  and the result (1.66)  $\vec{v} = \text{grad } \phi$ , the operator  $(\text{grad div})$  can, in equation (1.68), be replaced by the Laplacian operator  $\Delta$  (since here  $\text{rot } \vec{v} = \text{rot grad } \phi = 0$ ). However, it is recommended that one uses the “notation”  $\Delta$  carefully since its expression, when applied to a vector  $\vec{v}$ , cannot be directly transposed from its expression when it operates on a scalar as here  $\Delta = \text{grad div} - \text{rot rot}$  and not  $(\text{div grad})$ .

**1.3.4. Problems at the boundaries**

The equations in the previous sections must be satisfied for any values of the variables  $\vec{r}$  and  $t$  in the considered space and time domains. For the sake of conciseness in this book, this point is not constantly stated, but it must not be forgotten. Therefore, since the equations of propagation involve second-order spatial and time operators, the general solutions depend on two arbitrary functions. The following example shows a relatively general case that is constrained only by the condition of linear acoustics in a fluid at rest ( $V_E = 0$ ) (Figure 1.5).

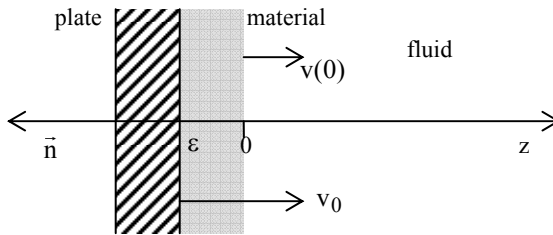

**Figure 1.5.** Plane wall with local reaction

A wall constituted of a curved surface, the curvature of which is small enough to approximate the plate by its tangent plane  $z = -\epsilon$ , is animated with a velocity  $V_0$  along the normal  $z$  axis. It is assembled in the space  $(-\epsilon, 0)$  with an elastic and resistive material characterized by its “impedance”  $Z$  defined, in the Fourier domain, in the ration of the pressure  $p(0)$  applied on its face at  $z = 0$  (with  $z > 0$ ) to the speed of variation of thickness  $[V_0 - v(0)]$  where  $v(0)$  represents the velocity at the interface material/fluid at  $(z = 0)$ :

$$Z = \frac{p(0)}{V_0 - v(0)}. \tag{1.69}$$

Using the Fourier transform of Euler’s equation (1.56) and not considering any source,  $v(0)$  can be expressed as

$$v(0) = \frac{-\partial p / \partial z}{i\omega\rho_0} = \frac{\partial p / \partial n}{i\omega\rho_0},$$

where  $\vec{n}$  represents the normal vector outward the considered domain (D), here  $z > 0$ . Impedance (1.69) becomes, for  $z = 0$  (at the boundary):

$$\frac{\partial p}{\partial n} + ik_0\beta p = U_0, \quad (1.70)$$

where  $\beta = \rho_0 c_0 / Z$  is the normalized admittance (dimensionless) of the material (different from the coefficient of augmentation of isochoric pressure  $\beta$ ),  $k_0 = \omega / c_0$  is the wavenumber, the ratio of the angular frequency imposed by a sinusoidal source and to wave velocity  $\left[ c_0 = \sqrt{\gamma / (\rho_0 \chi_T)} \right]$ , and  $U_0 = i\omega\rho_0 V_0$ ,  $V_0$  being the vibration velocity imposed to the wall at  $z = -\varepsilon$ .

This equation, only valid at  $z = 0$ , is a boundary condition on the pressure field  $p$  and its first derivative (this is expected as the equation of propagation involves spatial second-order derivatives), and a function  $U_0$  representing the effect of a “source” of boundary acoustic energy.

In the case where  $V_0 = 0$ ,  $Z = p(0) / (-v(0))$ , and taking equation (1.70) in the form of a homogeneous and hybrid boundary condition:

$$\frac{\partial p}{\partial n} + ik_0\beta p = 0. \quad (1.71)$$

If, in addition, the material is perfectly rigid,  $v(0) = 0$  then  $Z \rightarrow \infty$  and  $\beta = 0$ ; the condition is called Neumann’s condition:

$$\frac{\partial p}{\partial n} = 0. \quad (1.72)$$

Conversely, if the wave propagates in a dense medium (a solid for example), the reaction force of the gas is, at the interface with a gas, in most cases negligible, resulting in Dirichlet’s conditions:

$$p = 0, \text{ at } z = 0. \quad (1.73)$$

In the time domain, equation (1.70) introduces a product of convolution noted “\*”:

$$\frac{\partial p}{\partial n} + \frac{1}{c_0} \frac{d\beta}{dt} * p = U_0 \quad (1.74)$$

where the notations  $p$ ,  $\beta$  and  $U_0$  are functions in the time domain and not their Fourier transforms (as in equation (1.70)).

Thus, modeling a real situation within a domain (D) limited by a surface (S) – a typical problem – becomes (within the hypothesis of linear acoustics in non-dissipative fluid at rest):

$$\left\{ \begin{array}{l} \left[ \Delta - \frac{1}{c_0^2} \frac{\partial^2}{\partial t^2} \right] p = -f, \quad \forall \vec{r} \in (D), \quad \forall t \in (t_0, \infty), \\ \frac{\partial p}{\partial n} + \frac{1}{c_0} \frac{\partial \beta}{\partial t} * p = U_0, \quad \forall \vec{r} \in (S), \quad \forall t \in (t_0, \infty), \\ p \text{ and } \partial p / \partial t \text{ are known } \forall \vec{r} \in (D) \text{ at the initial moment } t = t_0. \end{array} \right. \quad (1.75)$$

$$(1.76)$$

The spatial and time boundary conditions involve derivatives, the order of which is lower than the order of the differential operators in the equation of propagation by at least one unit (as mathematics state it); the acoustic field can be fully characterized only if one knows its value at (S) and at  $t = t_0$  as well as its first derivatives (in time and spatial domains).

The condition (1.71) is a local condition (the reaction of the wall depends on the considered location). However, this approximation is not always acceptable, for example in the case when coupling occurs between the vibrational state of the wall and the acoustic field, if the wall is a medium of vibration propagation. The acoustic problem in fluid is then coupled with another problem: the vibration field of the partition, etc. (see Chapter 8).

## 1.4. Density of energy and energy flow, energy conservation law

### 1.4.1. Complex representation in the Fourier domain

It is convenient to define, in harmonic regime, the complex magnitudes  $p(\vec{r})$  and  $v(\vec{r}, t)$  associated to the real pressure variation and particle velocity noted  $\underline{p}(\vec{r}, t)$  and  $\underline{v}(\vec{r}, t)$  in sections 1.4.1 and 1.4.3:

$$\underline{p}(\vec{r}, t) = \text{Re} \left[ \underline{p}(\vec{r}) e^{i\omega t} \right] = \frac{1}{2} \left[ \underline{p}(\vec{r}) e^{i\omega t} + \underline{p}^*(\vec{r}) e^{-i\omega t} \right], \quad (1.77)$$

$$\underline{\vec{v}}(\vec{r}, t) = \text{Re} \left[ \underline{\vec{v}}(\vec{r}) e^{i\omega t} \right] = \frac{1}{2} \left[ \underline{\vec{v}}(\vec{r}) e^{i\omega t} + \underline{\vec{v}}^*(\vec{r}) e^{-i\omega t} \right]. \quad (1.78)$$

These complex quantities contain information on the magnitudes and phases ( $\varphi_p$  and  $\varphi_v$ ) of the wave:

$$\underline{p}(\vec{r}) = |\underline{p}(\vec{r})| e^{i\varphi_p} \quad \text{and} \quad \underline{v}_i(\vec{r}) = |\underline{v}_i(\vec{r})| e^{i\varphi_v}, \quad (1.79)$$

where  $|\underline{v}_i(\vec{r})|$  is the  $i^{\text{th}}$  component of the vector whose length is equal to the modulus of the complex velocity which is, from now on, improperly noted  $|\underline{\vec{v}}(\vec{r})|$  for conciseness.

The forthcoming calculation of the energy density and energy flow is carried out using the complex notation and the density  $\rho$ , for a homogeneous non-dissipative fluid at rest, within the linear acoustic approximation.

#### 1.4.2. Energy density in an “ideal” fluid

The total energy density is the sum of the kinetic and potential energy densities. The variation of kinetic energy density  $E_c$ , kinetic energy per unit volume, is related to the instantaneous particle velocity  $\underline{\vec{v}}$  by

$$E_c = \frac{1}{2} \rho_0 \underline{\vec{v}} \cdot \underline{\vec{v}} = \frac{1}{2} \rho_0 \underline{v}^2. \quad (1.80)$$

The potential energy, or internal energy of the fluid, is the energy that is stored by the fluid when evolving from a state of rest to an acoustic state characterized by the variables  $p$  and  $\rho$ . It is then defined by an integral calculated between those two states:

$$\int dE_p = \int (dQ + dW) = \int dW.$$

The latter equation illustrates the adiabatic property of the phenomena. In writing that  $\rho = \rho_0 + \delta\rho$ , the efficient elementary work received by a particle, when normalized to a unit volume, becomes (Figure 1.6)

$$dW = -\underline{\rho} \underline{p} dV = \frac{\underline{p}}{\underline{\rho}} d(\underline{\delta\rho}).$$

Ignoring the terms of higher orders and according to the law  $\underline{p} \approx c_0^2 \underline{\delta\rho}$  yields

$$dW \approx \frac{\underline{p}}{\rho_0} d(\underline{\delta\rho}) = \frac{c_0^2}{\rho_0} \underline{\delta\rho} d(\underline{\delta\rho}).$$

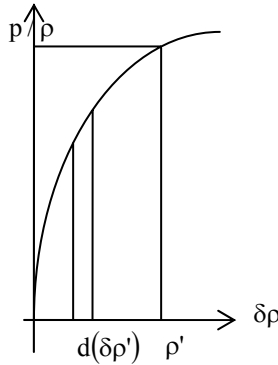

**Figure 1.6.** *Clapeyron's diagram*

The potential energy density can be written, at a given time, as

$$E_p = \frac{c_0^2}{\rho_0} \int_0^{\rho'} \underline{\delta\rho} d(\underline{\delta\rho}) = \frac{c_0^2}{\rho_0} \frac{\rho'^2}{2} = \frac{p^2}{2\rho_0 c_0^2}. \tag{1.81}$$

Thus, the local total energy density is given by

$$E_i = E_c + E_p = \rho_0 \frac{v^2}{2} + \frac{p^2}{2\rho_0 c_0^2}. \tag{1.82}$$

It is important to note that  $\underline{p}$  and  $\underline{\bar{v}}$  represent in equation (1.82), the real parts of the pressure and the velocity. Thus, using the complex notation (the exponent “\*” referring to the complex conjugate quantity) and considering equation (1.77):

$$\begin{aligned}
 \underline{p}^2 &= \frac{1}{4} \left[ p^2 e^{2i\omega t} + (p^*)^2 e^{-2i\omega t} + 2p p^* \right], \\
 &= \frac{1}{4} \left[ |p|^2 e^{2i(\omega t + \varphi_p)} + |p|^2 e^{-2i(\omega t + \varphi_p)} + 2|p|^2 \right], \\
 &= \frac{|p|^2}{2} \left[ \cos 2(\omega t + \varphi_p) + 1 \right],
 \end{aligned}$$

and the time average value (over the period  $T$ ), given by  $\langle \underline{p}^2 \rangle = \frac{1}{T} \int_0^T \underline{p}^2 dt$ , can be written as

$$\langle \underline{p}^2 \rangle = |p|^2 / 2.$$

Finally, the local average value of the total energy density is

$$E = \langle E_i \rangle = \langle E_c \rangle + \langle E_p \rangle = \frac{1}{4} \left[ \rho_0 |v|^2 + \frac{1}{\rho_0 c_0^2} |p|^2 \right]. \quad (1.83)$$

### 1.4.3. Energy flow and acoustic intensity

The acoustics intensity is, by definition, the energy that travels through a unit area per unit of time; it is an energy flow. The instantaneous flow of energy  $I_i$  is the product of the pressure variation (force per unit of area) and the particle velocity (displacement per unit of time):

$$\begin{aligned}
 \bar{I}_i &= \underline{p} \underline{v} = \frac{1}{4} |p| \left[ e^{i(\omega t + \varphi_p)} + e^{-i(\omega t + \varphi_p)} \right] |\bar{v}| \left[ e^{i(\omega t + \varphi_v)} + e^{-i(\omega t + \varphi_v)} \right], \\
 &= \frac{1}{4} |p| |\bar{v}| \left[ e^{i(2\omega t + \varphi_p + \varphi_v)} + e^{-i(2\omega t + \varphi_p + \varphi_v)} + e^{i(\varphi_p - \varphi_v)} + e^{-i(\varphi_p - \varphi_v)} \right], \\
 &= \frac{1}{2} |p| |\bar{v}| \left[ \cos(2\omega t + \varphi_p + \varphi_v) + \cos(\varphi_p - \varphi_v) \right].
 \end{aligned}$$

The quantity  $\frac{1}{2} |p| |\vec{v}| \cos(2\omega t + \varphi_p + \varphi_v)$  varies in time with the pulsation  $2\omega$  and is called the fluctuating power, while the quantity  $\frac{1}{2} |p| |\vec{v}| \cos(\varphi_p - \varphi_v)$  represents the mean power transmitted.

The acoustic intensity is the average of the instantaneous intensity over a period. Since the average of the fluctuating power is null, it can be written as

$$\begin{aligned} \vec{I} = \langle \vec{I}_i \rangle &= \frac{1}{2} |p| |\vec{v}| \cos(\varphi_p - \varphi_v) = \frac{1}{2} \operatorname{Re} [p \vec{v}^*] = \frac{1}{2} \operatorname{Re} [p^* \vec{v}] \\ &= \frac{1}{4} (p \vec{v}^* + p^* \vec{v}). \end{aligned} \quad (1.84)$$

To the mean value of the intensity, called active intensity,  $\vec{I} = \frac{1}{2} \operatorname{Re} [p \vec{v}^*]$ , is associated the reactive intensity  $\vec{J} = \frac{1}{2} \operatorname{Im} [p \vec{v}^*]$  to form the complex acoustic intensity vector:

$$\vec{\Pi} = \vec{I} + i \vec{J} = \frac{1}{2} p \vec{v}^*, \quad (1.85)$$

where

$$\vec{I} = \frac{1}{2} |p| |\vec{v}| \cos(\varphi_p - \varphi_v) \quad (1.86)$$

and

$$\vec{J} = \frac{1}{2} |p| |\vec{v}| \sin(\varphi_p - \varphi_v). \quad (1.87)$$

These two vector quantities are often measured with intensity probes, which are made of pressure and velocity sensors and an analyzer.

The active intensity  $\vec{I}$  is a vectorial description of the acoustic energy transfer; it is the time average energy flow (of null divergence). The reactive intensity  $\vec{J}$  expresses the non-propagative local energy transfers (of null rotational).

The acoustic power of a source is the total energy flow (active intensity) that travels through a surface  $S$  surrounding the source:

$$P_A = \iint_S \vec{I} \cdot d\vec{S}. \quad (1.88)$$

The rotational of the intensity  $\vec{\Pi}$  is

$$\text{rot } \vec{\Pi} = \text{rot} \left( \frac{1}{2} p \vec{v}^* \right) = \frac{1}{2} (\text{grad } p) \wedge \vec{v}^* + \frac{1}{2} p \text{rot } \vec{v}^*.$$

Considering that, by hypothesis,  $\text{rot } \vec{v}^* = \vec{0}$  and using Euler's equation to eliminate the variable  $p$ , and separating the real and imaginary parts of the particle velocity  $\vec{v}$ , one obtains:

$$\text{rot } \vec{\Pi} = \text{rot } \vec{I} = \frac{\rho\omega}{2} \text{Im} \left[ \vec{v} \wedge \vec{v}^* \right] = \frac{\omega}{c_0^2} \frac{\vec{I} \wedge \vec{J}}{\langle E_p \rangle}, \quad (1.89)$$

$$\text{rot } \vec{J} = \vec{0}. \quad (1.90)$$

The divergence of the intensity  $\vec{\Pi}$  can be written as

$$\text{div } \vec{\Pi} = \text{div} \frac{1}{2} (p \vec{v}^*) = \frac{1}{2} p \text{div } \vec{v}^* + \vec{v}^* \cdot \text{grad } p.$$

Substituting Euler's equation and the mass conservation law yields

$$\text{div } \vec{\Pi} = i \text{div } \vec{J} = i 2\omega (\langle E_p \rangle - \langle E_c \rangle), \quad (1.91)$$

$$\text{div } \vec{I} = 0. \quad (1.92)$$

This property is in agreement with the previous interpretation of the active intensity: a conservative field representing the transfer of acoustic energy. The divergence of the reactive intensity is proportional to the difference between the potential and kinetic energy densities; it highlights the stationary characteristic of a wavefield.

The rotational of the active intensity is null if  $\vec{I}$  and  $\vec{J}$  are parallel and is maximum when orthogonal; it can then be interpreted as an indicator of near field ( $\vec{I}$  and  $\vec{J}$  are perpendicular at the vicinity of a very directive source) or far field (where  $\vec{I}$  and  $\vec{J}$  are parallel).



### 1.4.4. Energy conservation law

The quantities considered in this paragraph are instantaneous and real quantities (the underline notation is therefore suppressed).

In one limits the analysis to “ideal” fluids and within the approximation of linear acoustics, substituting into the general relation

$$\operatorname{div}(\underline{p} \underline{\vec{v}}) = \underline{p} \operatorname{div} \underline{\vec{v}} + \underline{\vec{v}} \cdot \operatorname{grad} p,$$

the mass conservation law

$$\operatorname{div} \underline{\vec{v}} = -\frac{1}{\rho_0} \frac{\partial \rho'}{\partial t} + q = -\frac{1}{\rho_0 c_0^2} \frac{\partial p}{\partial t} + \frac{\alpha}{C_p} h + q$$

and Euler’s equation

$$\operatorname{grad} p = -\rho_0 \frac{\partial \underline{\vec{v}}}{\partial t} + \rho_0 \underline{\vec{F}},$$

leads immediately to

$$\begin{aligned} \operatorname{div}(\underline{p} \underline{\vec{v}}) &= -\frac{p}{\rho_0 c_0^2} \frac{\partial p}{\partial t} - \rho_0 \underline{\vec{v}} \cdot \frac{\partial \underline{\vec{v}}}{\partial t} + p q + \frac{\alpha}{C_p} p h + \rho_0 \underline{\vec{v}} \cdot \underline{\vec{F}}, \\ &= -\frac{1}{2\rho_0 c_0^2} \frac{\partial p^2}{\partial t} - \frac{\rho_0}{2} \frac{\partial v^2}{\partial t} + p q + \frac{\alpha}{C_p} p h + \rho_0 \underline{\vec{v}} \cdot \underline{\vec{F}}. \end{aligned}$$

This is called the law of energy conservation and is written as

$$\frac{\partial}{\partial t} E_i + \operatorname{div}(\underline{p} \underline{\vec{v}}) = \rho_0 \underline{\vec{v}} \cdot \underline{\vec{F}} + p q + \frac{\alpha}{C_p} p h. \quad (1.93)$$

This equation gives the law of energy conservation at any given time (all the more so for an average over a period of time).

The interpretation can be easily understood by integrating this relation over a fixed domain  $D_0$  delimited by a surface  $S_0$  in the considered domain of fluid. By applying the divergence theorem, one obtains

$$\frac{\partial}{\partial t} \iiint_{D_0} E_i dD + \iint_{S_0} p \vec{v} \cdot d\vec{S} = \iiint_{D_0} \left( \rho_0 \vec{v} \cdot \vec{F} + p q + \frac{\alpha}{C_p} p h \right) dD. \quad (1.94)$$

The sum of the energy variation in the domain  $D_0$  and the outward energy flow, per unit of time, is equal to the energy input from the sources. Note that the conditions of Dirichlet or Neumann (respectively  $p = 0$  or  $\vec{v} = \vec{0}$  over the domain boundary  $S_0$ ) are conservative since there is no energy dissipation at the boundaries of the domain  $D_0$ .

## Chapter 1: Appendix

# Some General Comments on Thermodynamics

### A.1. Thermodynamic equilibrium and equation of state

If one or several variables (also called coordinates) defining a thermodynamic system vary, spontaneously or under the action of exterior systems, the considered system is subjected to a change of state. If these coordinates are invariant, the system is in thermodynamic equilibrium (mechanical, chemical, thermal equilibriums etc. all at once).

Experience has shown that the variables used to define the equilibrium of a homogeneous fluid are the pressure  $P$ , volume  $V$  and temperature  $T$ , and that only two of these variables are necessary to define the state of the homogeneous fluid at equilibrium. In other words,  $P$ ,  $V$  and  $T$  do not constitute a set of three independent coordinates; there exists a relationship of the type  $F(P, V, T) = 0$ , referred to as the equation of the state of the system (constituted of the mass of considered fluid). The equations

$$PV - nRT = 0 \quad \text{and} \quad \left( P + \frac{a}{V^2} \right) (V - b) - nRT = 0$$

are two examples of equations of states that are satisfied by two types of gases (more or less idealized): perfect gases and Van der Waals gases (the equation of perfect gases is a convenient approximation for propagation in homogeneous fluids). Generally, the equation of state is unknown or partly unknown; it is then useful to develop further the thermodynamic formalism by admitting nothing else than the existence of these functions, and correlatively postulating that all the functions describing the variations of the system are dependent on only two

variables. More generally, for systems that are more complicated than homogeneous fluids, the number of independent variables is greater than two (note: systems that are described by multi-variables are not the prerogative of thermodynamics!). It is therefore useful to underline a few points concerning the functions of several variables.

## A.2. Digression on functions of multiple variables (study case of two variables)

### A.2.1. *Implicit functions*

The following equation of state shows the implicit function  $F$  of variables  $P$ ,  $V$  and  $T$ . Often one needs to give up trying to transform this equation into one of the form  $P = P(V, T)$ ,  $V = V(P, T)$  or  $T = T(P, V)$ ; first, because most of the time the function  $F$  is unknown, and, secondly, even when known, it can be too complex to be reduced to one of these forms. Nevertheless, it is always possible to write these expressions showing that two variables are enough to define the state of a system at equilibrium.

Considering an infinitesimal transformation from the state  $P, V, T$  to the state  $P + dP, V + dV, T + dT$ , the equation of state  $F(P, V, T) = 0$  leads to the equality

$$(\partial F / \partial V) dV + (\partial F / \partial P) dP + (\partial F / \partial T) dT = 0 \quad (1.95)$$

and the following equations, derived from equation (1.95):

$$\begin{aligned} dP &= \frac{\partial P}{\partial T} dT + \frac{\partial P}{\partial V} dV, \\ dV &= \frac{\partial V}{\partial T} dT + \frac{\partial V}{\partial P} dP, \\ dT &= \frac{\partial T}{\partial P} dP + \frac{\partial T}{\partial V} dV, \end{aligned} \quad (1.96)$$

In case of infinitesimal change of state during which one of the coordinates does not vary,  $V$  for example ( $dV = 0$ ), the others variables vary of quantities denoted  $dP)_V$  and  $dT)_V$ . The resulting quotient,  $dP)_V / dT)_V$  for example, is the partial differential  $\partial P / \partial T$  that is also noted  $\partial P / \partial T)_V$  or  $dP / dT)_V$ . If there are more than two independent variables (noted  $x, y, z, t, u$ , etc.) and during the infinitesimal transformation only two variations are non-null (say  $x$  and  $y$ ), the corresponding

partial derivative is written  $\partial x/\partial y)_{z,t,u,\dots}$ . Accordingly, equations (1.95) and (1.96) lead to

$$\begin{aligned} \left. \frac{\partial P}{\partial T} \right|_V &= -\frac{\partial F/\partial T}{\partial F/\partial P} = \frac{1}{\partial T/\partial P)_V}, \\ \left. \frac{\partial T}{\partial V} \right|_P &= -\frac{\partial F/\partial V}{\partial F/\partial T} = \frac{1}{\partial V/\partial T)_P}, \\ \left. \frac{\partial V}{\partial P} \right|_T &= -\frac{\partial F/\partial P}{\partial F/\partial V} = \frac{1}{\partial P/\partial V)_T}. \end{aligned}$$

Multiplying term by term the previous three equations yield

$$\left. \frac{\partial V}{\partial P} \right|_T \left. \frac{\partial P}{\partial T} \right|_V \left. \frac{\partial T}{\partial V} \right|_P = -1. \quad (1.97)$$

Among the previous differential coefficients, many depend on the considered mass of fluid. It is preferable to substitute these coefficients with mass independent quantities. This observation leads to the wide use of three easily-measurable quantities:

- the thermal expansion coefficient  $\alpha = \frac{1}{V} \partial V/\partial T)_P$ ;
- the coefficient of thermal pressure variation  $\beta = \frac{1}{P} \partial P/\partial T)_V$ ;
- the coefficient of isothermal compressibility  $\chi_T = -\frac{1}{V} \partial V/\partial P)_T$ .

Equation (1.97) can finally be written as

$$\alpha = \beta \chi_T P. \quad (1.98)$$

For a perfect gas, it is very simple to express these coefficients as

$$\alpha = \beta = 1/T \quad \text{and} \quad \chi_T = 1/P.$$

Note: the differential ratio of a certain function (for example  $Q(T, V)$ ) representing the quantity of heat  $Q$  as a function of temperature  $T$  and volume  $V$  to the variation of one of its variables (i.e. the temperature  $T$ ), written  $(dQ/dT)_V$ , is called the heat capacity at constant volume. However, this ratio is not the partial derivative of a state function  $Q$  with respect to the temperature that could be described as the “heat content” of the system. This notion of “heat content” of a system is nonsense.

### A.2.2. Total exact differential form

Let  $f(x, y, z)$  be a function of three independent variables  $(x, y, z)$ . The variation  $df$  of  $f$  is a function of the variables  $(x, y, z, dx, dy, dz)$  when  $(x, y, z)$  vary with the quantities  $(dx, dy, dz)$  and is given by

$$df = \frac{\partial f}{\partial x} dx + \frac{\partial f}{\partial y} dy + \frac{\partial f}{\partial z} dz.$$

The “inverse” problem can be presented as follows: let  $P_1(x, y, z)$ ,  $P_2(x, y, z)$  and  $P_3(x, y, z)$  be three functions and the differential form

$$dg = P_1(x, y, z)dx + P_2(x, y, z)dy + P_3(x, y, z)dz.$$

For the function  $g(x, y, z)$  to exist, it must satisfy the conditions

$$\frac{\partial g}{\partial x} = P_1(x, y, z), \quad \frac{\partial g}{\partial y} = P_2(x, y, z), \quad \frac{\partial g}{\partial z} = P_3(x, y, z),$$

thus

$$\begin{aligned} \frac{\partial^2 g}{\partial y \partial x} = \frac{\partial P_1}{\partial y} \quad \text{and} \quad \frac{\partial^2 g}{\partial x \partial y} = \frac{\partial P_2}{\partial x} &\Rightarrow \frac{\partial P_1}{\partial y} = \frac{\partial P_2}{\partial x}, \\ \frac{\partial^2 g}{\partial z \partial x} = \frac{\partial P_1}{\partial z} \quad \text{and} \quad \frac{\partial^2 g}{\partial x \partial z} = \frac{\partial P_3}{\partial x} &\Rightarrow \frac{\partial P_1}{\partial z} = \frac{\partial P_3}{\partial x}, \\ \frac{\partial^2 g}{\partial z \partial y} = \frac{\partial P_2}{\partial z} \quad \text{and} \quad \frac{\partial^2 g}{\partial y \partial z} = \frac{\partial P_3}{\partial y} &\Rightarrow \frac{\partial P_2}{\partial z} = \frac{\partial P_3}{\partial y}. \end{aligned}$$

These three conditions, called Cauchy’s conditions, are necessary and sufficient for the function  $g$  to exist. If  $dg$  is not the differential of a function, then the function  $g$  does not exist. The variation  $dg$  of the physical quantity  $g$  exists of course, but this variation depends on the way the variations are set. The quantity  $g$  is then not a “potential” function or a state function, in which case the variation during a transformation does not only depend on the initial and final state, but on the path taken between these two states. The heat quantity  $Q$  mentioned above is an example.

To a same quantity  $q$  can be associated, if it exists, a function  $q_1(x, y)$  of two state variables  $(x, y)$  or a function  $q_2(z, y)$  of the two state variables  $(z, y)$ . It is common, in physics, to give the same name to these two functions as they describe

the same physical quantity and any ambiguity is avoided by always specifying the variables. It is then possible to write the variation of the quantity  $q$  as

$$dq = (\partial q / \partial x)_y dx + (\partial q / \partial y)_x dy = (\partial q / \partial z)_y dz + (\partial q / \partial y)_z dy .$$

The quantities in the right-hand side terms are all different from each other (with the exception of  $dy$ ), and the variation  $dq$  is of course the same whatever expression is used.

## Chapter 2

# Equations of Motion in Dissipative Fluid

### 2.1. Introduction

Even though acoustic dissipation can, in many situations, be ignored (in closed spaces with absorbing walls for example), there are still some cases where one needs to take it into account. Long-distance propagation, even submitted to various perturbations, such as reflection, refraction, diffusion, diffraction etc., and acoustic fields in guides and rigid walled cavities (thus very reflective) are among the examples that generally require consideration of dissipation.

Attenuation of sound waves can result from various processes related to the characteristics of the propagation fluid. For example, the phenomenon of cavitation in liquids (creation and destruction of bubbles by the propagation of an acoustic wave) is a cause of significant attenuation. It is not the purpose of this chapter to present in detail the processes of dissipation in “complex” fluids, but to describe the processes of dissipation that most often occur in “complex” fluids and “simple” fluids (and in gases in particular) where its importance in many real situations is well established. The three considered phenomena are those related to viscosity (shear and volume viscosity), thermal conduction and molecular relaxation (in polyatomic molecules). These processes are introduced in the equations of motions as additional factors. For example, Euler’s equation (1.31) is modified by the introduction of a factor expressing the viscosity stresses. This factor is presented as an operator  $\theta_v$  applied to the particle velocity  $\vec{v}$  (which formula is demonstrated and given in section 2.2),

$$\rho \frac{d\vec{v}}{dt} + \text{grad } P + \theta_h(\vec{v}) = \rho \vec{F}. \quad (2.1)$$



However, the mass conservation law (1.29) is not modified

$$\frac{d\rho}{dt} + \rho \operatorname{div} \bar{v} = \rho q . \quad (2.2)$$

The equation of continuity of entropy (1.34) is completed by a factor introducing the heat flow due to thermal conduction, and a higher-order factor for the heat supplied by viscous friction. These phenomena are represented by an operator noted  $O_h$  applied to the temperature and the particle velocity (whose formula is demonstrated and given in section 2.3),

$$T \frac{dS}{dt} + O_h(T, \bar{v}) = h . \quad (2.3)$$

Two laws of thermodynamics are necessary to reduce this four-variables problem ( $P, \rho, T, S$ ) to a two-variables problem (bivariant media). Equations (1.22) and (1.23) can be used to eliminate the variables  $\rho$  and  $S$ . If molecular relaxation is taken into account, equation (1.22) alone is modified so that the isobaric heat capacity  $C_p$  is replaced by a time-dependent operator  $C_p^*$  (whose formula is demonstrated and given in section 2.4),

$$dS = \frac{C_p^*}{T} dT - \frac{P\beta\chi_T}{\rho} dP , \quad (2.4)$$

$$d\rho = \rho\chi_T(dP - P\beta dT) . \quad (2.5)$$

For the sake of generality, equations (2.1) to (2.5) are those including the effects of non-linearity, mean flow, non-homogeneity, etc. The dissipative effects considered above are presented, one by one, in the following three sections.

## 2.2. Propagation in viscous fluid: Navier-Stokes equation

Taking viscosity into account requires the definition of the deformation of and stresses on the considered continuous media and relating the two associated tensors (Hooke's law) to obtain a new expression of the fundamental law of dynamics: Navier-Stokes equation (generalized Euler's equation). The considered fluids are assumed lightly viscous, which results in a Reynold's number far greater than one,

$$R_e = \frac{\rho_0 c_0^2}{N\mu} \gg 1 , \quad (2.6)$$

where  $N$  denotes the frequency of the frequency-dependent component of the wave and  $\mu$  is the coefficient of shear viscosity of the fluid. In acoustics, the effects due to these phenomena are always “weak”, resulting in the use of simple linear laws to describe them.

### 2.2.1. Deformation and strain tensor

The analysis of the deformation of a particle of fluid is necessary to evaluate the forces applied on this particle by the surrounding ones. The notions of deformation and rotation considered in solids are replaced, for fluids, by the notions of deformation rate and rotation rate (meaning that the considered variations are expressed per unit of time).

#### 2.2.1.1. Field of velocity gradient near a point

At a given time  $t$ , a particle located at the point  $\vec{r}$  has a velocity  $\vec{v}(\vec{r}, t)$  and another particle located at  $\vec{r} + d\vec{r}$  has the velocity  $\vec{v} + d\vec{v}$ . Each component  $dv_i$  ( $i = 1$  to  $3$ ) of the spatial variation of velocity  $d\vec{v}$  is written, at the first order of the displacement components  $dx_j$  ( $i = 1$  to  $3$ ), as

$$dv_i = \sum_{j=1,3} \frac{\partial v_i}{\partial x_j} dx_j. \quad (2.7)$$

It is important to note that the translational movement of the whole system is not included in the present description as it does not induce deformation. The quantities

$$G_{ij} = \partial v_i / \partial x_j \quad (2.8a)$$

are the components of a second-order tensor, the deformation rate tensor or velocity gradient tensor. For the following developments, the elements of the  $3 \times 3$  associated matrix are decomposed into a symmetric and an anti-symmetric part

$$G_{ij} = e_{ij} + \omega_{ij}, \quad (2.8b)$$

$$\text{with } e_{ij} = (1/2)(\partial v_i / \partial x_j + \partial v_j / \partial x_i), \quad (2.8c)$$

$$\text{and } \omega_{ij} = (1/2)(\partial v_i / \partial x_j - \partial v_j / \partial x_i). \quad (2.8d)$$

2.2.1.2. *Pure deformation, associated to the symmetric tensor  $e_{ij}$ : the diagonal terms*

The tensor, the components of which  $e_{ij}$ , is symmetrical and consists of diagonal and non-diagonal terms. In the case of a velocity gradient field that consists only of diagonal terms  $(\partial v_i / \partial x_i)$ , if at the time  $t$  the components of the velocity  $\vec{v}(\vec{r}, t)$  of the point  $\vec{r}$  are  $v_1, v_2, v_3$  then, according to equation (2.7), those of the velocity  $\vec{v}(\vec{r} + d\vec{r}, t)$  of the point  $\vec{r} + d\vec{r}$  are

$$v_1 + (\partial v_1 / \partial x_1) dx_1, \quad v_2 + (\partial v_2 / \partial x_2) dx_2, \quad v_3 + (\partial v_3 / \partial x_3) dx_3.$$

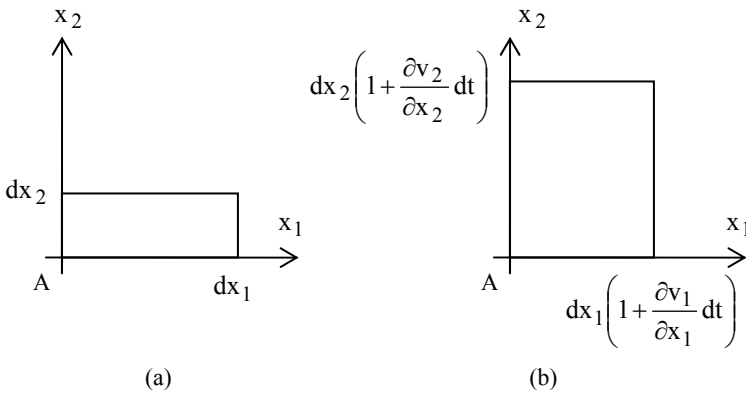

**Figure 2.1.** *Deformation of a rectangular surface in a flow in which the velocity gradient field consists only of diagonal terms of the type  $(\partial v_1 / \partial x_1)$ : (a) not deformed rectangle at the time  $t$ ; (b) state of the rectangle at the time  $(t + dt)$*

The increase in length (i.e.  $d(dx_1)$ ) of a side (of length  $dx_1$ ) of the volume element  $dx_1 dx_2 dx_3$ , during the period  $dt$ , can be written as

$$d(dx_1) = [v_1 + (\partial v_1 / \partial x_1) dx_1] dt - v_1 dt = (\partial v_1 / \partial x_1) dx_1 dt.$$

Similar expressions can be obtained for  $d(dx_2)$  and  $d(dx_3)$ . The relative increase of length of a side (i.e.  $dx_1$ ), during the interval of time  $dt$ , can then be written as

$$d(dx_1) / dx_1 = (\partial v_1 / \partial x_1) dt. \tag{2.9}$$

Consequently, the diagonal terms of the tensor of components  $(\partial v_i / \partial x_i)$  represent the speed of elongation of the fluid element in the corresponding direction

( $x_1$ -direction for the side  $x_1$ ). During such deformation, opposite sides of a parallelepipedic volume (elementary or not) remain parallel to one another. The volume expands (respectively contracts itself), and the relative variation of volume is

$$dV/V = [(\partial v_1/\partial x_1) + (\partial v_2/\partial x_2) + (\partial v_3/\partial x_3)]dt = \text{div}(\vec{v})dt. \quad (2.10)$$

Clearly, the function  $\text{div}(\vec{v})$ , equal to the trace of the matrix  $\partial v_i/\partial x_j$  (sum of the diagonal terms), represents the volume extension rate (it is null for an incompressible fluid: Figure 2.1).

### 2.2.1.3. Pure deformation associated to the symmetric tensor $e_{ij}$ : the non-diagonal terms

In the case of a field of velocity gradient consisting only of the non-diagonal terms of the tensor  $G_{ij}$  ( $\partial v_i/\partial x_j$  terms with  $i \neq j$ ), if at the time  $t$  the components of the velocity  $\vec{v}(\vec{r}, t)$  of the point  $\vec{r}$  are  $v_1, v_2, v_3$ , then those of the velocity  $\vec{v}(\vec{r} + d\vec{r}, t)$  of the point  $\vec{r} + d\vec{r}$  are, according to equation (2.7),

$$\begin{aligned} v_1 + (\partial v_1/\partial x_2)dx_2 + (\partial v_1/\partial x_3)dx_3, \\ v_2 + (\partial v_2/\partial x_1)dx_1 + (\partial v_2/\partial x_3)dx_3, \\ v_3 + (\partial v_3/\partial x_1)dx_1 + (\partial v_3/\partial x_2)dx_2. \end{aligned}$$

Consequently, the angle  $d\alpha_1$ , of which the side  $dx_1$  rotates in the  $(x_1, x_2)$ -plane during the period  $dt$ , is given by

$$\begin{aligned} d\alpha_1/dt &\approx \text{tg}(d\alpha_1)/dt = [v_2(x_1 + dx_1, x_2, x_3) - v_2(x_1, x_2, x_3)]/dx_1, \\ d\alpha_1/dt &\approx \partial v_2/\partial x_1. \end{aligned} \quad (2.11a)$$

Similarly, the angle  $d\alpha_2$ , of which the side  $dx_2$  rotates in the  $(x_1, x_2)$ -plane, during the period  $dt$ , is given by

$$\begin{aligned} d\alpha_2/dt &\approx \text{tg}(d\alpha_2)/dt = -[v_1(x_1, x_2 + dx_2, x_3) - v_1(x_1, x_2, x_3)]/dx_2, \\ d\alpha_2/dt &\approx \partial v_1/\partial x_2. \end{aligned} \quad (2.11b)$$

The negative sign in equation (2.11b) is introduced to take into account the fact that the angle  $d\alpha_2$  is of opposite sign to the elementary displacement  $dv_1 dt$  (for  $dx_2 > 0$ ). Consequently, the variation ( $d\gamma/dt$ ) of the angle (right angle at rest) between the sides  $dx_1$  and  $dx_2$ , per unit of time (Figure 2.2) is given by

$$d\gamma/dt = -[d\alpha_1 - d\alpha_2]/dt = -[\partial v_2/\partial x_1 + \partial v_1/\partial x_2] = -2e_{12}. \quad (2.12)$$

Similar arguments can be made to deal with the two other planes  $((x_1, x_3)$  and  $(x_2, x_3)$ ) still assuming “small deformations”. Consequently, the non-diagonal terms  $e_{ij}$  ( $i \neq j$ ) of the symmetric part of the tensor  $G_{ij}$ , represent the speed of local angular deformation.

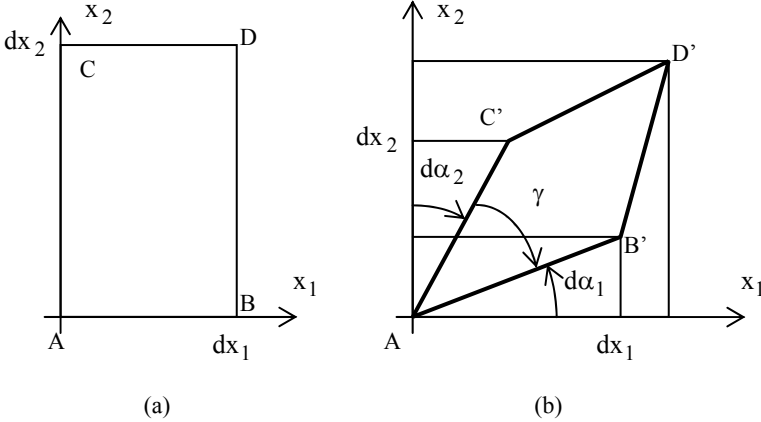

**Figure 2.2.** Deformation of a rectangular surface in a flow which velocity gradient field consists only of non-diagonal symmetric terms: (a) not deformed rectangle at the instant  $t$ ; (b) state of the rectangle at the time  $(t + dt)$

The symmetric tensor  $e_{ij}$ , called the deformation tensor due to the properties presented above, can also be written as a sum of a diagonal term and a term, of which the trace is null (the sum of the diagonal terms is null) as

$$\begin{aligned}
 e_{ij} &= \frac{1}{3} \delta_{ij} \sum_{\ell} e_{\ell\ell} + \left[ e_{ij} - \frac{1}{3} \delta_{ij} \sum_{\ell} e_{\ell\ell} \right] \\
 &= \frac{1}{3} \delta_{ij} \operatorname{div}(\vec{v}) + \left[ e_{ij} - \frac{1}{3} \delta_{ij} \operatorname{div}(\vec{v}) \right] \\
 &= t_{ij} + d_{ij}.
 \end{aligned}
 \tag{2.13}$$

The diagonal term  $t_{ij}$  is associated with the volume expansion of fluid elements (see equation (2.10)) while the tensor  $d_{ij}$  is called “deviator” and is associated with all the deformations at constant volume (since its trace is null).

2.2.1.4. Pure rotation associated with the anti-symmetric tensor  $\omega_{ij}$

No elongation is associated with the anti-symmetric tensor  $\omega_{ij} = (1/2)(\partial v_i / \partial x_j - \partial v_j / \partial x_i)$  (equation (2.8d)) since all diagonal terms are null

(the trace is null). Moreover, considering any movements described by the matrix  $\omega_{ij}$  alone is equivalent to considering that the tensor  $e_{ij}$ , in  $G_{ij} = e_{ij} + \omega_{ij}$ , is null and therefore that  $\partial v_i / \partial x_j = -\partial v_j / \partial x_i$ . Consequently, the variation ( $d\gamma / dt$ ) of the angle between the sides  $dx_1$  and  $dx_2$  per unit of time, described previously by

$$d\gamma / dt = -[d\alpha_1 - d\alpha_2] / dt = -[\partial v_2 / \partial x_1 + \partial v_1 / \partial x_2] = -2e_{12}$$

is null (as well as its equivalent for the other couple of sides of the elementary parallelepiped).

Thus, in the hypothesis that its motion is described only by the anti-symmetric tensor  $\omega_{ij}$ , the considered elementary parallelepiped does not exhibit any deformation (neither linear nor angular), but only a global rotation. The angle  $d\alpha$  associated with this rotation (Figure 2.3), previously defined, is written

$$d\alpha = (\partial v_2 / \partial x_1) dt = (1/2)[\partial v_2 / \partial x_1 - \partial v_1 / \partial x_2] dt = \omega_{12} dt. \quad (2.14)$$

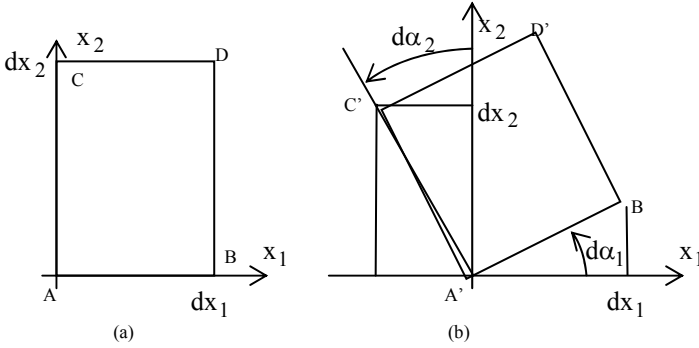

**Figure 2.3.** Effect of the anti-symmetric part of the velocity gradient field on a rectangle. The velocity gradient tensor consists only of non-diagonal terms of the type  $\partial v_i / \partial x_j$ , with  $i \neq j$ , such as  $\partial v_i / \partial x_j = -\partial v_j / \partial x_i$ ; (a) rectangle at the time  $t$ ; (b) state of the rectangle at the time  $(t + dt)$

The pseudo-vorticity vector of the flow  $\vec{\omega}$ , whose components are

$$\omega_k = -\sum_{ij} \varepsilon_{ijk} \omega_{ij}, \quad (2.15)$$

where  $\varepsilon_{ijk} = +1$  for a direct permutation of the indexes  $i, j$  and  $k$ ,  $\varepsilon_{ijk} = -1$  for an inverse permutation and  $\varepsilon_{ijk} = 0$  if at least two of its indexes are equal, can be written (according to equations (2.14) and (2.15)) as

$$\vec{\omega} = \text{rot } \vec{v}. \quad (2.16)$$

The pseudo-vector

$$\vec{\Omega} = (1/2) \text{rot } \vec{v}, \quad (2.17)$$

whose third component is equal to  $d\alpha_1$ , called the vortical vector, represents the local angular velocity of a fluid element.

To summarize, the velocity gradient tensor  $G_{ij} = \partial v_i / \partial x_j$  can be written as the sum of three terms

$$G_{ij} = t_{ij} + d_{ij} + \omega_{ij},$$

where:

- $t_{ij}$  is a diagonal tensor accounting for the variation of volume of the fluid elements;
- $d_{ij}$  is a symmetric tensor of null trace accounting for the deformations of the fluid elements at constant volume;
- $\omega_{ij}$  is an anti-symmetric tensor accounting for the overall rotation of the fluid elements.

Considering that a simple, shear motion is nothing more than the superposition of a deformation without rotation (with or without volume variations) and of a rotation, it can be represented by the tensor  $G_{ij}$ . However, the above approach does not apply on a translation motion of all particles of the fluid.

### 2.2.2. Stress tensor

The action of the exterior medium on an element of volume (contact between the particles within the volume) results in forces applied to the surface of the considered element of volume. These forces per unit of area are called stresses. In general, stresses depend on the location on the surface of the volume element and of its normal vector which accounts for five parameters. It is noted  $\vec{T}(M, \vec{n})$  and often simply  $\vec{T}(\vec{n})$  (Figure 2.4).

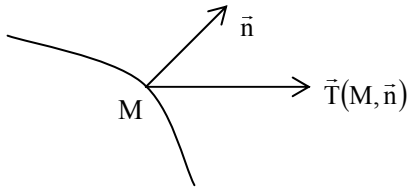

**Figure 2.4.** Representation of a stress  $\vec{T}$  applied on the point  $M$  of an interface between two media

The quantity  $\sigma_{nn} = \vec{T} \cdot \vec{n}$  leads to the expression of its normal  $\sigma_{nn} \vec{n}$  and tangential (stress associated to the shear or sliding motions)  $\vec{T} - \sigma_{nn} \vec{n}$  components. The more general stress tensor  $\vec{\sigma}$  of components  $\sigma_{ij}$  can be defined, for a given value of  $j$  and, in the particular case of  $\vec{T}(\vec{n})$  where  $\vec{n}$  is collinear positive to the unit axis  $\vec{x}_j$ , as

$$\vec{T}(\vec{x}_j) = \sum_i \sigma_{ij} \vec{x}_i. \quad (2.18)$$

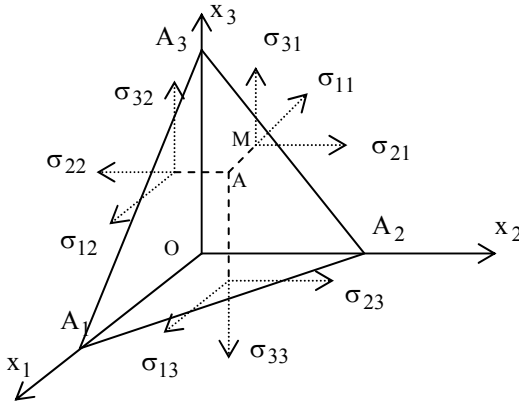

**Figure 2.5.** Components of the stress tensor applied on an elementary volume  $OA_1A_2A_3$

In other words,  $\sigma_{ik}$  represents the stress applied along the direction  $\vec{x}_i$  on the face normal to the direction  $\vec{x}_k$  (Figure 2.5). To verify that the stress  $\vec{T}(\vec{n})$  ( $\forall \vec{n}$ ) is perfectly described by the nine components  $\sigma_{ij}$ , it is necessary to find the relationship between the vector  $\vec{T}(\vec{n})$  and the tensor  $\vec{\sigma}$ . For that, one can apply the



fundamental law of dynamics to the volume element  $dV$  defined by  $OA_1A_2A_3$  and take the limit when  $OM \rightarrow 0$  with the point  $M$  belonging to the face  $A_1A_2A_3$ . The external stresses applied on the elementary domain  $dV$  are noted  $\bar{T}(\bar{n})$  on the face,  $A_1A_2A_3$  and  $\bar{T}(-\bar{x}_j) = -\sum_i \sigma_{ij} \bar{x}_j$  on each face with unitary normal outwardly directed  $(-\bar{x}_j)$ . This equation, projected onto the axis  $\bar{x}_j$  can be written as

$$\rho \gamma_j dV = T_j dS_{A_1A_2A_3} - (\sigma_{j1} dS_{23} + \sigma_{j2} dS_{13} + \sigma_{j3} dS_{12}) \quad (2.19)$$

since the quantities  $dS_{ij}$  are arithmetic,

$$\rho \gamma_j dV = \left[ T_j - (n_1 \sigma_{j1} + n_2 \sigma_{j2} + n_3 \sigma_{j3}) \right] dS_{A_1A_2A_3},$$

where the factors  $n_i$  denote the components of the vector  $\bar{n}$  normal to the face  $A_1A_2A_3$ .

Since the acceleration of the component  $\gamma_j$  has an upper bound, that the elementary volume  $dV$  is proportional to  $OM^3$  and that the elementary surface  $dS_{A_1A_2A_3}$  is proportional to  $OM^2$ ,

$$\lim_{OM \rightarrow 0} \left( T_j - \sum_i n_i \sigma_{ji} \right) = 0.$$

The relationship between  $\bar{T}$  and  $\bar{\sigma}$  is therefore

$$T_i = \sum_j \sigma_{ij} n_j. \quad (2.20)$$

### 2.2.3. Expression of the fundamental law of dynamics

#### 2.2.3.1. Equation of equilibrium of the forces

When projected onto the  $\bar{x}_i$  axis and applied to a domain  $(D)$  delimited by a surface  $(S)$ , the equation of equilibrium of the forces is written as

$$\iiint_D (\rho F_i - \rho \gamma_i) dD + \iint_S T_i(\bar{n}) dS = 0, \quad (2.21)$$

where  $\rho \bar{F}$  is a force per unit of volume in the bulk of the domain  $(D)$  and  $\bar{\gamma}$  denotes the acceleration ( $\bar{\gamma} = d\bar{v}/dt$ ).

When considering equation (2.20), the application of the theorem of divergence gives

$$\iint_S T_i(\vec{n})dS = \sum_j \iint_S \sigma_{ij} n_j dS = \sum_j \iiint_D \sigma_{ij,j} dD, \quad (2.22)$$

where, by definition,  $\sigma_{ij,k} = \frac{\partial \sigma_{ij}}{\partial x_k}$ .

Considering the domain (D) to be arbitrarily chosen and assuming the integrand continuous, the equation of equilibrium can be expressed locally as

$$\rho \gamma_i = \rho F_i + \sigma_{ij,j} \text{ where } j \text{ is the index of summation.} \quad (2.23)$$

In the particular case where only pressure forces are considered,  $\sigma_{ij} = -P\delta_{ij}$  and equation (2.23) takes the form of Euler's equation.

### 2.2.3.2. Equation of equilibrium of the momentums: symmetry of the stress tensor

The resulting moment on any given point O within the continuous medium is null. Thus

$$\iiint_D O\vec{M} \wedge (\rho\vec{F} - \rho\vec{\gamma}) dD + \iint_S O\vec{M} \wedge \vec{T}(M, \vec{n})dS = 0.$$

This equality holds if  $\vec{T} = -P\vec{n}$ , i.e. if  $\sigma_{ij} = -P\delta_{ij}$ , when only pressure forces are considered (see section 1.2.7).

Herein, the tensor  $\sigma_{ij}$  is not diagonal. Projected on the  $\vec{x}_1$  axis, this equation becomes

$$\begin{aligned} & \iiint_D \rho [x_2(F_3 - \gamma_3) - x_3(F_2 - \gamma_2)] dD \\ & + \sum_j \iint_S [x_2(n_j \sigma_{3j}) - x_3(n_j \sigma_{2j})] dS = 0, \end{aligned}$$

thus, applying the theorem of divergence,

$$\iiint_D \left[ x_2 \rho (F_3 - \gamma_3) - x_3 \rho (F_2 - \gamma_2) + \sum_j \frac{\partial}{\partial x_j} (x_2 \sigma_{3j} - x_3 \sigma_{2j}) \right] dD = 0,$$

Or, according to equation (2.23),

$$\iiint_D [x_2(-\sigma_{3j,j}) - x_3(-\sigma_{2j,j}) + x_2(\sigma_{3j,j}) - x_3(\sigma_{2j,j}) + \sigma_{32} - \sigma_{23}] dV = 0.$$

This equality must be verified for any given domain (D), therefore  $\sigma_{23} = \sigma_{32}$ , or more generally

$$\sigma_{ij} = \sigma_{ji}. \quad (2.24)$$

The stress tensor (similarly to the tensor of deformation) is symmetric. This property yields the following form for the equation of equilibrium

$$\rho \vec{\gamma} = \rho \vec{F} + \operatorname{div} \vec{\sigma}. \quad (2.25)$$

### 2.2.3.3. Behavioral law (Hookes's law) for the viscous media, Navier-Stokes equation

As the relation between stresses and deformations (Hookes's law) is generally assumed for small deformations of elastic solids,

$$\sigma_{ij} = \sum_{k\ell} C_{ijk\ell} e_{k\ell}, \quad (2.26)$$

(where the component of the tensor  $C_{ijk\ell}$  denotes the rigidity coefficients), there exists a linear law between the deformations of a viscous fluid and their cause that is considered a good approximation for the problem of acoustic propagation.

Consequently, in a viscous fluid submitted to small deformations, presenting then small velocity gradients, the stresses are assumed to be linearly dependent on the first spatial derivatives of the velocity. The independent terms of these spatial derivatives must not appear since, in fluids, internal frictions only occur if different regions present different velocities. Therefore, the stresses are null when the velocity is independent of the point considered. Moreover, for a uniform rotation of the fluid, the stresses cancel each other, only the symmetric terms of the velocity gradient tensor are non-null.

Thus, for a homogeneous and isotropic fluid, only two coefficients are considered, those corresponding to the two types of deformation presented in section 2.2.1. These coefficients are the diagonal tensor  $t_{ij}$  (accounting for the volume variation) and the tensor of null trace  $d_{ij}$  (accounting for the deformations at constant volume). Consequently, the stress tensor can be written, without loss of generality and considering the case of pressure stresses, as

$$\sigma_{ij} = -P\delta_{ij} + \mathfrak{T}_{ij}, \quad (2.27)$$

where, according to the definitions of  $t_{ij}$  and  $d_{ij}$  (equation 2.13), the viscous stress tensor  $\overline{\mathfrak{T}}$ , which components are denoted  $\mathfrak{T}_{ij}$ , is

$$\mathfrak{T}_{ij} = \mu \left( \frac{\partial v_i}{\partial x_j} + \frac{\partial v_j}{\partial x_i} - \frac{2}{3} \delta_{ij} \operatorname{div} \vec{v} \right) + \eta \delta_{ij} \operatorname{div} \vec{v}. \quad (2.28)$$

The coefficients  $\mu$  and  $\eta$ , generally small, are respectively called the shear viscosity coefficient and the bulk viscosity coefficient. The coefficient  $\mu$  measures the “intensity” of the attenuation by shear, due to the energy transfers induced by the translation of the molecules between adjacent layers with different velocities and to these induced between the uniform motion (considered herein) and the disordered motion related to the entropy of the system (the Brownian motion, on a microscopic scale, induces energy exchanges). The coefficient  $\eta$  measures the “intensity” of the attenuation due to the interaction between the rotational and vibrational motions of the molecules (perturbed by shocks at the microscopic scale) and the “component” of acoustic translation, responsible for the volume variations of the particles. Stokes law stipulates that  $\eta$  is null for a monoatomic gas.

The substitutions of equations (2.27) and (2.28) of the stresses tensor  $\sigma_{ij}$  into the equation of motion (2.25) yields the Navier-Stokes equation in the equivalent form

$$\rho \frac{dv_i}{dt} = - \frac{\partial P}{\partial x_i} + \mathfrak{T}_{ij,j} + \rho F_i \quad (\text{sum over } j), \quad (2.29)$$

or, within the hypothesis that  $\mu$  and  $\eta$  depend insignificantly on the field variables,

$$\rho \frac{d\vec{v}}{dt} = - \operatorname{grad} P + \mu \Delta \vec{v} + \left( \eta + \frac{\mu}{3} \right) \operatorname{grad} \operatorname{div} \vec{v} + \rho \vec{F}, \quad (2.30)$$

or, considering the identity  $\Delta = \operatorname{grad} \operatorname{div} - \operatorname{rot} \operatorname{rot}$  (which should be understood as the Laplacian of a vector),

$$\rho \frac{d\vec{v}}{dt} = - \operatorname{grad} P + \left( \eta + \frac{4}{3} \mu \right) \Delta \vec{v} + \left( \eta + \frac{\mu}{3} \right) \operatorname{rot} \operatorname{rot} \vec{v} + \rho \vec{F}, \quad (2.31)$$

$$\rho \frac{d\vec{v}}{dt} = - \operatorname{grad} P + \left( \eta + \frac{4}{3} \mu \right) \operatorname{grad} \operatorname{div} \vec{v} - \mu \operatorname{rot} \operatorname{rot} \vec{v} + \rho \vec{F}. \quad (2.32)$$

Equation (2.32) is of the same form as equation (2.1) and is the first equation of motion. The second equation, the mass conservation law (equation 2.2), is unchanged by the addition of dissipative processes and therefore remains, as in the first chapter,

$$\frac{d\rho}{dt} + \rho \operatorname{div} \bar{v} = \rho q . \quad (2.33)$$

The interpretation of the form of the stress tensor  $\bar{\mathfrak{T}}$  following equation (2.28) can be carried out by considering the energy associated to viscosity. If  $\varepsilon$  is the internal energy per unit of mass (potential energy) associated to the acoustic perturbation, the instantaneous energy accumulated by the fluid, expressed by unit of volume, is the sum of its kinetic and potential energies  $(1/2)\rho v^2 + \sigma\varepsilon$ . From a thermodynamic point of view, it is a macroscopic, ordered energy.

The variation per unit of time of the kinetic energy, expanded to a low order (which is sufficient for the perturbation factors related to dissipative processes), can be written as

$$\frac{\partial}{\partial t} \left( \rho \frac{v^2}{2} \right) = \frac{v^2}{2} \frac{\partial \rho}{\partial t} + \rho \bar{v} \frac{\partial \bar{v}}{\partial t} , \quad (2.34)$$

leading to the expression of the factors  $\partial \rho / \partial t$  and  $\partial \bar{v} / \partial t$ , using respectively the mass conservation law and Navier-Stokes equation:

$$\begin{aligned} \frac{\partial}{\partial t} \left( \rho \frac{v^2}{2} \right) = & -\frac{v^2}{2} \operatorname{div}(\rho \bar{v}) \\ & + \bar{v} \cdot \left[ \rho \bar{F} - \operatorname{grad} P + \operatorname{div} \bar{\mathfrak{T}} - \rho \bar{v} \cdot \operatorname{grad} \bar{v} \right] + \rho \frac{v^2}{2} q . \end{aligned}$$

Therefore, the contribution of the stresses described by the tensor  $\bar{\mathfrak{T}}$  to the variation of kinetic energy per unit of time is  $\bar{v} \operatorname{div} \bar{\mathfrak{T}}$ , or

$$\sum_{ij} v_i \frac{\partial \mathfrak{T}_{ij}}{\partial x_j} = \sum_{ij} \left[ \frac{\partial}{\partial x_j} (v_i \mathfrak{T}_{ij}) - \mathfrak{T}_{ij} \frac{\partial v_i}{\partial x_j} \right] = \operatorname{div}(\bar{v} \cdot \bar{\mathfrak{T}}) - \sum_{ij} \mathfrak{T}_{ij} \frac{\partial v_i}{\partial x_j} . \quad (2.35)$$

There are only two possible causes of the variation of kinetic energy related to viscosity: variation by kinetic energy transfer between adjacent elementary volumes (impulse transfer) and variation by conversion of macroscopic kinetic energy (ordered energy) into heat energy (disordered energy) due to viscous friction

(Brownian shocks between molecules). These processes correspond respectively to the two terms associated with the viscosity in equation (2.35). The demonstration is not presented herein, but convincing points can be made to defend this argument:

– the sum of the transfers of kinetic energy over the spatial domain is obviously null and for a close surface  $S$  of infinite extend,

$$\iiint_D \operatorname{div}(\bar{\mathbf{v}} \cdot \bar{\mathfrak{T}}) dD = \iint_S (\bar{\mathbf{v}} \cdot \bar{\mathfrak{T}}) \cdot d\bar{\mathbf{S}} = 0, \quad (2.36)$$

since the velocity field  $\bar{\mathbf{v}}$  vanishes at infinity;

– the sum over the spatial domain of the kinetic energy variation due to the conversion of the latter into heat (which is an internal energy as well) is not null. This holds for the factor

$$\sum_{ij} \iiint_D \mathfrak{T}_{ij} (\partial v_i / \partial x_j) dD \neq 0. \quad (2.37)$$

The conversion of kinetic energy into heat energy must therefore be introduced in the variation per unit of time of potential energy per unit of volume  $\partial(\rho\varepsilon)/\partial t$ . More precisely, by writing the following consecutive relationships:

$$\begin{aligned} d(\rho\varepsilon) &= \varepsilon d\rho + \rho d\varepsilon = \varepsilon d\rho + \rho \left[ TdS - Pd\left(\frac{1}{\rho}\right) \right] \\ &= \rho TdS + \left( \frac{P}{\rho} + \varepsilon \right) d\rho = \rho TdS + Hd\rho, \end{aligned} \quad (2.38)$$

where  $H = \frac{P}{\rho} + \varepsilon$  is the enthalpy per unit of mass, it appears that the irreversible variation of heat  $\sum_{ij} \mathfrak{T}_{ij} (\partial v_i / \partial x_j)$  per unit of volume and time contributes to the variation of entropy involved in equation (2.38),

$$\rho T \frac{dS}{dt} = \sum_{ij} \mathfrak{T}_{ij} \frac{\partial v_i}{\partial x_j} + \rho T \frac{dS_e}{dt}, \quad (2.39)$$

where  $T \frac{dS_e}{dt}$  represents the incoming heat due to other potential processes (factor  $T \frac{dS_h}{dt} + h$  in the following section).

Note: a detailed interpretation of the energy equations is presented in the Appendix to this chapter.

### 2.3. Heat propagation: Fourier equation

The heat transfer between adjacent particles can occur by thermal conduction, convection or radiation. The temperature difference between adjacent particles, due to spatial- and time-dependent pressure variations in the fluid, is so small and so fast that the effects of radiation are not accessible to any experimental set-up and are therefore non-existent to the eye of an observer. The heat transfers (entropy transfers) by convection are introduced by the term  $\bar{v} \cdot \text{grad}$  of the operator  $d/dt$  (equation (1.25)). The heat flow through the interface between adjacent particles, induced by the temperature gradients associated with the pressure gradients, resulting in a decrease of the amplitudes of these pressure gradients compared to that which they would be according to the hypothesis of adiabaticity, remains to be introduced. This dissipative effect is of the same order of magnitude as the effect related to viscosity. This observation is expressed by the non-dimensional number (Prandtl number)  $Pr = \mu \cdot C_p / \lambda$  (where  $\lambda$  is the coefficient of thermal conduction) that is always finite.

The elementary heat transfer to a fluid domain of unit mass is written as the sum of three terms:

- the heat energy from the conversion, by viscosity effect, of kinetic ordered energy (acoustic or not) into heat (disordered energy)  $\sum_j \mathfrak{T}_{ij} \partial v_i / \partial x_j$  (according to equation (2.39));
- the heat energy due to a heat flow through the boundary of the domain by conduction, denoted  $T dS_h$  ;
- the heat energy from an external source, defined by the heat quantity introduced per unit of mass and time, denoted “h”, as

$$\rho T \frac{dS}{dt} = \sum_{ij} \mathfrak{T}_{ij} \frac{\partial v_i}{\partial x_j} + \rho T \frac{dS_h}{dt} + \rho h . \quad (2.40)$$

The factor  $\mathfrak{T}_{ij} \partial v_i / \partial x_j$  introduces the product of a stress by a velocity gradient. Therefore, its magnitude is defined by the product of an acoustic quantity ( $\partial v_i / \partial x_j$ ) by a tensor  $\mathfrak{T}$  that represents a small perturbation compared to the other acoustic quantities. It is an infinitesimal factor, the magnitude of which is strictly greater than two. It is therefore negligible compared to the other factors that are, *a priori*, of order of magnitude equal to two in the energy equation (2.40).

The expression of the factor  $T dS_h / dt$  is obtained by taking the following steps. The heat flow  $\bar{J}$  (heat quantity per unit of time traveling through the unit surface perpendicular to the direction of this flow) is a function of the temperature gradient

and can therefore be expanded into power series limited to the first order since the gradients in acoustics are small (the term of order zero is null as the flow vanishes when the gradient is null). The Fourier's law illustrates this fact simply, writing

$$\vec{J} = -\lambda \text{grad}T, \quad (2.41)$$

where the coefficient  $\lambda$  is called the coefficient of thermal conductivity.

Moreover, the outgoing total heat flow through a surface (S) limiting a closed domain (D) can be written, using Green's theorem, as

$$\iint_S \vec{J} \cdot d\vec{S} = \iiint_D \text{div} \vec{J} dD. \quad (2.42)$$

The incoming heat flow per unit of volume is then written in the form

$$\rho T dS_h / dt = -\text{div} \vec{J} = \text{div} (\lambda \text{grad} T),$$

and for homogenous and isotropic fluids (with respect to thermal conduction),

$$\rho T dS_h / dt = \lambda \Delta T. \quad (2.43)$$

Finally, the elementary heat transfer per unit of volume to the fluid can be approximated by

$$\rho T dS / dt \approx \lambda \Delta T + \rho h. \quad (2.44)$$

The latter equation is in agreement with equation (2.3). It is the third equation of motion recalled in this chapter.

The heat conduction associated with the temperature gradient between adjacent particles is partly responsible for the dissipation of acoustic energy into heat. A simple physical interpretation can be obtained by examining qualitatively the "trajectory" of the acoustic motion during a cycle in the Clapeyron's diagram (pressure as a function of the volume) in Figure 2.6.



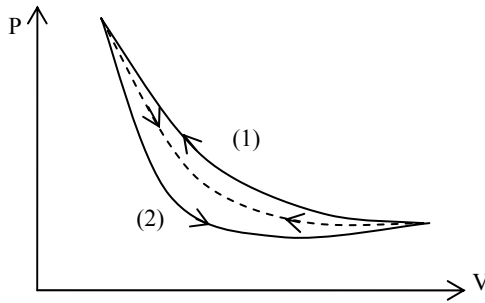

**Figure 2.6.** “Acoustic” cycle in dissipative fluid on Clapeyron’s diagram

Without dissipation, the trajectory is given by the dotted line: there is only one trajectory taken during the compression and the depression phases. The work  $(-\int PdV)$  received by the particle during the compression phase is equal to the work released during the depression phase. However, if by thermal conduction, the considered particle exchanges heat with its adjacent particles during the cycle, the work released (2<sup>nd</sup> curve on Clapeyron’s diagram) is lesser than the work received during the compression phase (1<sup>st</sup> curve): part of the mechanical energy (acoustic) is dissipated into heat.

This effect is due to the thermal conduction: when the pressure increases, the temperature in the elementary volume considered increases as well (Lechatelier’s law, equation (1.22)), but the outward heat transfer from this volume occurs with delay. The average temperature (and consequently the product  $PV$ ) is then greater in the first curve than in the 2<sup>nd</sup> curve: the energy provided to the volume during the compression phase is not released entirely during the decompression. This delay in “going back” to equilibrium is called a relaxation phenomenon. (The phenomena related to viscosity can also be interpreted as relaxation phenomena with delays in impulse transfers.) There are other relaxation phenomena occurring during propagation that are related to physical and chemical equilibrium. One is particularly important since it is responsible for most of the acoustic dissipation in specific conditions in air: the molecular thermal relaxation. It is presented in the forthcoming section.

## 2.4. Molecular thermal relaxation

### 2.4.1. Nature of the phenomenon

The processes of acoustic dissipation related to viscosity and thermal conduction occur in all fluids. In monoatomic gases, they are the only processes of dissipation to consider and are responsible for what is commonly called the “classical

absorption". However, in polyatomic gases, an additional phenomenon is to be considered as its importance is such that, within certain frequency ranges, it overwhelms the precedent phenomena (at least for the problems of propagation in infinite domains). It is the phenomenon of molecular thermal relaxation that is presented here for diatomic gases (i.e. oxygen and nitrogen in air). The generalization of the following description to polyatomic gases is straightforward.

When a gas is compressed, its temperature increases (Lechatelier's law, equation (1.22)). In other words, the motion of translation of the molecules is accelerated. The natural vibrational and rotational motions of diatomic molecules are then accelerated. At ambient temperature, the natural rotation can vary almost instantaneously (with respect to the period of the wave) when submitted to an exterior excitation. On the other hand, vibrational motion does not occur fully at ambient temperature (only at several thousand degrees) and varies only with delay when solicited (a very short delay in fact, but not always negligible for the common periods encountered in acoustics). This delay, called relaxation time, is proportional to the period of time between two consecutive molecular impacts and inversely proportional to the probability of energy transfer between translational and vibrational motions of the molecules. The relaxation time is significantly longer for a vibration than for a rotation since the number of inter-molecular shocks required for a translation/rotation energy transfer is inferior to the number of shocks required for a translation/vibration energy transfer. Therefore, when the pressure  $P$  in the considered volume increases under the excitation from adjacent volumes, the motion of translation of the molecules (solely responsible for the pressure  $P$ ) accelerates instantaneously, part of the translational energy is then converted with delay into vibrational energy. When the pressure starts to decrease, the vibrational energy keeps increasing before initiating a decrease by conversion into translation energy. Consequently, the pressure (due to the translational motion) happens to be greater during compression than during depression, resulting in an apparent loss of the wave's mechanical energy by relaxation, similar to the loss presented in the previous chapter. The consequence is an attenuation of the wave (Figure 2.6).

It is clear that if the relaxation time  $t_r$  (vibration reaction time to the excitation) is significantly smaller than the period  $1/f$ , the gas reaches its vibrational equilibrium instantaneously at any time; there is then no attenuation by relaxation. On the other hand, if  $t_r \gg 1/f$ , the vibrational motion is not excited, and consequently the gas behaves like a monoatomic gas (apart from the heat capacities  $C_V$  and  $C_P$ ). There is therefore no attenuation. The phenomenon then occurs within a domain where  $t_r$  and  $1/f$  are relatively close (Figure 2.7).

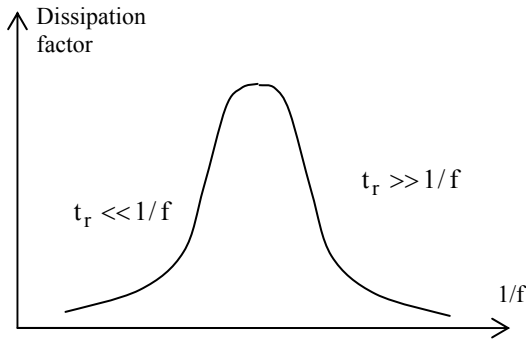

**Figure 2.7.** Representation of the principle of dissipation by molecular relaxation as a function of the period of the wave

### 2.4.2. Internal energy, energy of translation, of rotation and of vibration of molecules

The sum of the kinetic energies of translation  $U$  (for  $nN$  molecules, where  $N$  is the number of Avogadro) of a perfect gas (molecular gas with no interaction and negligible molecular volume), in equilibrium at the temperature  $T$ , can be written as a function of the mean quadratic velocity  $C^2$  of the molecules as

$$U = \sum m C^2 / 2 = n N m C^2 / 2 = n N 3kT / 2 = n(3R/2) T, \quad (2.45)$$

where  $m$  is the mass of one molecule.

Equations (2.45) convey a property of perfect gases: their internal energy depends only on the temperature. This can be verified by substituting the second equation (1.11) into equation (1.6) leading to the equality  $\ell = P$  and then to

$$dU = n M C_V dT + \ell dV - PdV = n M C_V dT. \quad (2.46)$$

By comparison of equation (2.46) with (2.45), the heat capacity of a mole of gas at constant volume is

$$M C_V = 3R / 2, \quad (2.47)$$

where  $C_V$  is the isochoric heat capacity.

For polyatomic gases, eventually introducing other forms of energy (energies of rotation and vibration of the molecules), the thermodynamic laws lead to the expression of a principle of energy equipartition: “The same quantity of energy  $kT/2$  is uniformly distributed, in average per molecule, over all degrees of freedom

and all forms of energy (kinetic and potential) once equilibrium is reached at the temperature  $T$ ." When generalizing the law  $dU = nMC_V dT$  to polyatomic gases, the principle of equipartition conveys, for monoatomic gases, the following (3 degrees of freedom in translation):

$$MC_V = 3R / 2 \quad (2.48)$$

and for polyatomic gases without vibrations (3 degrees of freedom in translation of the center of gravity and 2 degrees of freedom in rotation),

$$MC_V = 5R / 2 . \quad (2.49)$$

The specific isochoric heat capacity will now be noted  $C_V^{(t)}$  for monoatomic gases and  $C_V^{(tr)}$  for polyatomic gases.

Note: the vibrational motion of the molecules has been ignored so far since, at ambient temperature, in the case of oxygen  $O_2$  and nitrogen  $N_2$ , the magnitude of such motion is very small. It only occurs significantly at temperatures above 1,000K since the level of energy required to induce it, generated by the other types of motion, is reached above this temperature value (as statistical quantum mechanics teaches us). Moreover, three degrees of freedom are generally introduced when dealing with rotational motion. Only two degrees of freedom are considered here: those of rotation along the two axes perpendicular to each other and in the plane normal to the molecule axis. The rotation about the molecule's axis contributes only a very small amount of energy.

### 2.4.3. *Molecular relaxation: delay of molecular vibrations*

With respect to the periods of acoustic motions in the audible and lower ultrasound ranges, the time required for the energy transfers between translational and rotational motion is negligible. This observation is not valid in the case of vibrational motion since the probability of energy conversion into energy of vibration is smaller than its equivalent for any other types of motion. Therefore, under external excitation (here, acoustic), the variation of internal energy per unit of mass of the fluid can be written as

$$\frac{1}{nM} dU = C_V^{(tr)} \tau + \delta E_V , \quad (2.50)$$

where  $\tau \approx dT$  denotes the temperature variation and  $\delta E_V$  the variation of energy per unit of mass accumulated in the form of molecular vibrational energy.

Even though vibrational motion is relatively weakly excited, it still occurs in the air in normal conditions, and the associated relaxation phenomenon is, in certain conditions, responsible for most of the acoustic dissipation. Consequently, the simple following model is of practical importance.

Since there is delay in establishing a motion of vibration, the gas, at any given time, is not at equilibrium (energy  $C_V^{(v)}\tau$ ) and the rate of variation of the energy of vibration  $\delta E_V$ , written  $\partial(\delta E_V)/\partial t$ , is proportional (in a first approximation) to the difference between the instantaneous value  $\delta E_V$  and the value at the equilibrium  $C_V^{(v)}\tau$ . This property is expressed as

$$\frac{\partial(\delta E_V)}{\partial t} = -\frac{1}{\theta} \left( \delta E_V - C_V^{(v)}\tau \right), \quad (2.51)$$

where the factor of proportionality is inversely proportional to a time constant noted  $\theta$ . This equation can also be written as

$$(1 + \theta \partial / \partial t) \delta E_V = C_V^{(v)}\tau, \quad (2.52)$$

and its solution, obtained by the method of variation of the constant, is:

$$\delta E_V = \frac{e^{-t/\theta}}{\theta} \int_{(t)} e^{t'/\theta} C_V^{(v)}\tau dt', \quad (2.53)$$

$$\text{or } \delta E_V = \frac{1}{1 + \theta \partial / \partial t} C_V^{(v)}\tau. \quad (2.54)$$

Therefore, the variation of internal energy (equation (2.50)) can be written in the form

$$dU = nMC_V^*\tau, \quad (2.55)$$

where, denoting  $C_V = C_V^{(tr)} + C_V^{(v)}$ :

$$C_V^* = C_V \left[ 1 - \frac{C_V^{(v)}}{C_V} \frac{\theta \partial / \partial t}{1 + \theta \partial / \partial t} \right], \quad (2.56)$$

where the operators  $\theta \partial / \partial t$  and  $1/(1 + \theta \partial / \partial t)$  commute.

The “heat capacity” at constant pressure  $C_p^* = \frac{R}{M} + C_V^*$  (from equation (1.11)) takes the following operator form

$$C_p^* = C_p \left[ 1 - \frac{C_V^{(v)}}{C_p} \frac{\theta \partial / \partial t}{1 + \theta \partial / \partial t} \right], \quad (2.57)$$

and the ratio  $\gamma^* = C_p^* / C_V^*$  is expanded to the first order of  $C_V^{(v)} / C_p$ , thus

$$\frac{\gamma}{\gamma^*} \approx 1 - (\gamma - 1) \frac{C_V^{(v)}}{C_p} \frac{\theta \partial / \partial t}{1 + \theta \partial / \partial t}. \quad (2.58)$$

To summarize, the real factors  $C_p$ ,  $C_V$  and  $\gamma$  must be replaced in the Fourier domain by the complex factors  $C_p^*$ ,  $C_V^*$  and  $\gamma^*$ . In practice, this conveys changes of phase between the quantities ( $p, \rho', s, \bar{v}, \tau$ ), which are the consequences of delays in reaching equilibrium states.

## 2.5. Problems of linear acoustics in dissipative fluid at rest

The situation defined in the above heading generates systems of equations that can be applied to numerous problems and underlines several properties of acoustic waves in dissipative fluids. The second chapter aims to present these problems and properties.

### 2.5.1. Propagation equations in linear acoustics

Navier-Stokes equation (2.32) can be written as

$$\frac{1}{c_0} \frac{\partial \bar{v}}{\partial t} + \frac{1}{\rho_0 c_0} \text{grad } p = \ell_v \text{grad } \text{div } \bar{v} - \ell'_v \text{rot } \text{rot } \bar{v} + \frac{\bar{F}}{c_0}, \quad (2.59)$$

where  $\ell_v$  and  $\ell'_v$  are characteristic lengths defined by

$$\ell_v = \frac{1}{\rho_0 c_0} \left( \frac{4}{3} \mu + \eta \right), \quad \ell'_v = \frac{\mu}{\rho_0 c_0}, \quad (2.60)$$

and where  $\frac{1}{c_0^2} = \frac{\rho_0 \chi T}{\gamma}$ .

The equation of mass conservation (2.33), where the density variation  $\rho'$  is linearized using equation (2.5), becomes

$$\rho_0 c_0 \operatorname{div} \bar{v} + \gamma \frac{1}{c_0} \frac{\partial}{\partial t} (p - \hat{\beta} \tau) = \rho_0 c_0 q, \quad (2.61)$$

where  $\hat{\beta} = P_0 \beta$  and  $\tau = T - T_0$ .

Considering the expression of the variation of entropy per unit of mass and the relationships  $\alpha = P_0 \beta \chi_T$  (equation (1.98)) and  $C_p - C_v = (\gamma - 1) C_v = \alpha \hat{\beta} T_0 / \rho_0$  (equation (1.10)), the equation of heat conduction (Fourier equation (2.44)) becomes

$$\left[ \frac{1}{c_0} \frac{\partial}{\partial t} - \ell_h \Delta \right] \tau = \frac{\gamma - 1}{\hat{\beta} \gamma} \frac{1}{c_0} \frac{\partial p}{\partial t} + \frac{h}{c_0 C_p}, \quad (2.62)$$

where

$$\ell_h = \frac{\lambda}{\rho_0 c_0 C_p} \quad (2.63)$$

denotes the characteristic length of thermal diffusion. In the case of air, in normal conditions,  $\ell_v \sim 4.10^{-8}$  m and  $\ell_h \sim 6.10^{-8}$  m.

According to section 1.3.3, the particle velocity field  $\bar{v}$  is written as the superposition of a vortical velocity field  $\bar{v}_v$  (associated to the viscosity effects) and of a laminar velocity field  $\bar{v}_\ell$  (associated to the acoustic effects and thermal conduction effects called entropic effects) as

$$\begin{aligned} \bar{v} &= \bar{v}_\ell + \bar{v}_v, \\ \operatorname{rot} \bar{v}_\ell &= \bar{0} \text{ and } \operatorname{div} \bar{v}_\ell \neq 0, \\ \operatorname{rot} \bar{v}_v &\neq \bar{0} \text{ and } \operatorname{div} \bar{v}_v = 0. \end{aligned} \quad (2.64)$$

In numerous acoustic problems, apart from at the boundaries, the coupling between these two motions can be neglected. In such cases, equation (2.59) can be decomposed into two equations ((2.67) and (2.68)) and the system of three equations ((2.59), (2.61) and (2.62)) becomes

$$\frac{1}{c_0} \frac{\partial \tau}{\partial t} - \frac{\rho_0 c_0}{\gamma \hat{\beta}} \operatorname{div} \bar{v}_\ell = \frac{1}{\hat{\beta}} \frac{1}{c_0} \frac{\partial p}{\partial t} - \frac{\rho_0 c_0}{\gamma \hat{\beta}} q, \quad (2.65)$$

$$\left( \frac{1}{c_0} \frac{\partial}{\partial t} - \ell_h \Delta \right) \tau = \frac{\gamma-1}{\hat{\beta} \gamma} \frac{1}{c_0} \frac{\partial p}{\partial t} + \frac{h}{c_0 C_p}, \quad (2.66)$$

$$\left( \frac{1}{c_0} \frac{\partial}{\partial t} - \ell_v \Delta \right) \bar{v}_\ell = -\frac{1}{\rho_0 c_0} \text{grad } p + \frac{\bar{F}_\ell}{c_0}, \quad (2.67)$$

$$\left( \frac{1}{c_0} \frac{\partial}{\partial t} - \ell'_v \Delta \right) \bar{v}_v = \bar{F}_v / c_0, \quad (2.68)$$

$$\text{where } \text{div } \bar{v}_v = 0 \text{ and } \text{rot } \bar{v}_\ell = \bar{0}. \quad (2.69)$$

In equations (2.67) and (2.68), the external force field  $\bar{F}$  has been written as an irrotational force field  $\bar{F}_\ell$  and a non divergent force field  $\bar{F}_v$ .

When associated with the boundary conditions considered, this set of equations constitutes the base for the description of acoustic fields in many problems. To find the solutions, it is convenient to find the equations of propagation associated with the variables  $p$ ,  $\tau$  and  $\bar{v}_\ell$ . The mathematics is, in principle, simple, even though writing down the equations might be a lengthy task. Fortunately, in most situations, it is unnecessary to consider any source.

For example, the equation of propagation of the temperature variation  $\tau$  can be obtained by adopting the following method. The factor  $\text{div } \bar{v}_\ell$  can be eliminated from the previous system of equations by first applying the operator  $\text{div}$  to equation (2.67) and the operator  $\left( \frac{1}{c_0} \frac{\partial}{\partial t} - \ell_v \Delta \right)$  to equation (2.65), and then combining the results. The factors  $\partial p / \partial t$  and  $\Delta p$  are eliminated from the resulting equation using equation (2.66) and its Laplacian. After following such procedure, one obtains

$$\begin{aligned} \ell_h \left( 1 + \gamma \ell_v \frac{1}{c_0} \frac{\partial}{\partial t} \right) \Delta \Delta \tau - \left[ 1 + (\ell_v + \gamma \ell_h) \frac{1}{c_0} \frac{\partial}{\partial t} \right] \frac{1}{c_0} \frac{\partial}{\partial t} \Delta \tau + \frac{1}{c_0^3} \frac{\partial^3}{\partial t^3} \tau \\ = \frac{\gamma-1}{\gamma \hat{\beta}} \frac{\rho_0}{c_0} \frac{\partial}{\partial t} \left[ -\text{div } \bar{F}_\ell + \left( \frac{\partial}{\partial t} - c_0 \ell_v \Delta \right) \mathbf{q} \right] \\ + \frac{\gamma}{c_0 C_p} \left[ \frac{1}{c_0^2} \frac{\partial^2}{\partial t^2} - \left( \frac{1}{\gamma} + \frac{\ell_v}{c_0} \frac{\partial}{\partial t} \right) \Delta \right] h. \end{aligned} \quad (2.70)$$



The right-hand side term conveys the effect of the sources and can be simplified or, in most cases, eliminated as it is often sufficient to write this equation away from the sources. It is easy to verify that taken away from the sources, this equation becomes

$$\left[ \frac{1}{c_0} \frac{\partial}{\partial t} - \frac{\Gamma - R}{2} \left( \frac{1}{c_0} \frac{\partial}{\partial t} \right)^{-1} \Delta \right] \left[ \frac{1}{c_0^2} \frac{\partial^2}{\partial t^2} - \frac{\Gamma + R}{2} \Delta \right] \tau = 0, \quad (2.71)$$

$$\text{with } \Gamma = 1 + (\ell_v + \gamma \ell_h) \frac{1}{c_0} \frac{\partial}{\partial t}, \quad (2.72)$$

and

$$\begin{aligned} R &= \left[ 1 + 2 \left[ \ell_v - (2 - \gamma) \ell_h \right] \frac{1}{c_0} \frac{\partial}{\partial t} + (\ell_v - \gamma \ell_h)^2 \frac{1}{c_0^2} \frac{\partial^2}{\partial t^2} \right]^{1/2} \\ &\simeq 1 + \left[ \ell_v - (2 - \gamma) \ell_h \right] \frac{1}{c_0} \frac{\partial}{\partial t} - 2(\gamma - 1) \ell_h (\ell_v - \ell_h) \frac{1}{c_0^2} \frac{\partial^2}{\partial t^2}. \end{aligned} \quad (2.73)$$

The superior orders of the characteristic length make no physical sense since only the first orders of small deformations in the fundamental law of dynamics and of temperature gradients in the equation of thermal conduction are considered. Consequently, it is sensible to write

$$\frac{\Gamma + R}{2} \approx 1 + \ell_{v_h} \frac{1}{c_0} \frac{\partial}{\partial t} + O(\ell^2), \quad \text{with } \ell_{v_h} = \ell_v + (\gamma - 1) \ell_h \quad (2.74)$$

$$\text{and } \frac{\Gamma - R}{2} \left( \frac{1}{c_0} \frac{\partial}{\partial t} \right)^{-1} \simeq \ell_h \left[ 1 + (\gamma - 1) (\ell_v - \ell_h) \frac{1}{c_0} \frac{\partial}{\partial t} + O(\ell^2) \right], \quad (2.75)$$

as the order of magnitude of  $(\Gamma - R)$  ( $\ell_h \sim 6.10^{-8}$  m for the air in normal conditions) is much smaller than the order of magnitude of  $(\Gamma + R)$  (unit).  $O(\ell^2)$  denotes the infinitesimal second orders of the characteristic lengths  $\ell_v$  and  $\ell_h$ .

Equation (2.71) leads to the expression of the temperature variation  $\tau$  as a sum of an acoustic temperature  $\tau_a$  and an entropic temperature  $\tau_h$  that are respectively the solutions to the homogeneous equations (away from the sources)

$$\left[ \frac{1}{c_0^2} \frac{\partial^2}{\partial t^2} - (1 + \ell_{v_h} \frac{1}{c_0} \frac{\partial}{\partial t}) \Delta \right] \tau_a = 0, \quad (2.76)$$

$$\left[ \frac{1}{c_0} \frac{\partial}{\partial t} - \ell_h \left( 1 + (\gamma - 1)(\ell_v - \ell_h) \frac{1}{c_0} \frac{\partial}{\partial t} \right) \Delta \right] \tau_h = 0,$$

$$\text{or } \left[ \frac{1}{c_0} \frac{\partial}{\partial t} - \ell_h \Delta \right] \tau_h \approx 0. \quad (2.77)$$

Equation (2.76) is an equation of acoustic propagation in which the first factor conveys the inertia of the particle, the second its compressibility and the third the dissipation associated with viscosity and thermal conduction. Equation (2.77) is an equation of diffusion that is, when limited to the first order of  $\ell_h$ , the homogenous equation (2.66) (without the right-hand side term). The entropic temperature  $\tau_h$  is therefore associated to thermal conduction (responsible for the heat transfer). The effects of molecular relaxation, when considered, are to be introduced in the factor  $\frac{1}{c_0^2} \frac{\partial^2}{\partial t^2}$  of equation (2.76) by substituting the operator  $\gamma$  with  $\gamma^*$  in  $c_0^2 = \gamma P_0 / \rho_0$  (equation (2.58)).

The pressure variation (acoustic and entropic) and the laminar particle velocity (acoustic and entropic) satisfy the same equations (2.71), (2.76) and (2.77) as the temperature variation. The proof of this property (for the pressure  $p$ ) can be carried out by eliminating the factor  $\text{div} \vec{v}_\ell$  in combining equation (2.65) and the divergence of equation (2.67), then by eliminating the temperature  $\tau$ , applying the operator  $\left( \frac{1}{c_0} \frac{\partial}{\partial t} - \ell_h \Delta \right)$  to equation (2.66) and reporting it into the previous result. The equation of propagation of the particle velocity  $\vec{v}_\ell$  is obtained by first applying the operator  $\text{grad} \left( \frac{1}{c_0} \frac{\partial}{\partial t} - \ell_h \Delta \right)$  to equation (2.65) and eliminating  $\tau$ , combining the result with equation (2.66). The factor  $\text{grad} p$  is eliminated in the resulting equation by using equation (2.67).

### 2.5.2. Approach to determine the solutions

Preliminary note: until the end of this chapter, some basic notions concerning the solutions (particularly the plane wave solutions) of the classical equations of propagation are assumed as known by the reader. They are nevertheless set out in Chapter 4.

Finding the general solutions to the system of equations (2.65) to (2.69) is a simple task as long as the problem is taken away from the sources, a region where the solutions are known. Equation (2.68) for the vortical velocity field  $\vec{v}_v$ , and the equations (2.76) and (2.77) for, respectively, the acoustic temperature  $\tau_a$  and entropic temperature  $\tau_h$ , are classical equations of diffusion for  $\vec{v}_v$  and  $\tau_h$ , and of propagation for  $\tau_a$ . The solutions to such equations are known in the usual coordinate systems. The equations for the laminar acoustic and entropic velocity fields,  $\vec{v}_{\ell a}$  and  $\vec{v}_{\ell h}$ , for the acoustic and entropic pressures  $p_a$  and  $p_h$ , satisfy the same equations (2.76) and (2.77) as  $\tau_a$  and  $\tau_h$ . Therefore, obtaining the solutions for the variables  $p = p_a + p_h$ ,  $\vec{v}_\ell = \vec{v}_{\ell a} + \vec{v}_{\ell h}$ ,  $\tau = \tau_a + \tau_h$  and  $\vec{v}_v$  is reduced to solving classical equations of propagation and diffusion. However, for the acoustic and entropic variables  $(p, \vec{v}_\ell, \tau)$ , the solutions for two of them (i.e.  $\vec{v}_\ell$  and  $p$ ) can be derived from the solution for the third (i.e.  $\tau$ ). Reporting the solution  $\tau = \tau_a + \tau_h$  into equation (2.66), given equations (2.76) and (2.77), leads to

$$p = p_a + p_h, \quad (2.78)$$

where

$$p_a \simeq \frac{\gamma \hat{\beta}}{\gamma - 1} \left( 1 - \ell_h \frac{1}{c_0} \frac{\partial}{\partial t} \right) \tau_a \simeq \frac{\gamma \hat{\beta}}{\gamma - 1} \tau_a, \quad (2.78a)$$

$$p_h \simeq \gamma \hat{\beta} (\ell_v - \ell_h) \frac{1}{c_0} \frac{\partial}{\partial t} \tau_h \ll p_a. \quad (2.78b)$$

The report of these results into equation (2.67), given that equations (2.76) and (2.77) are satisfied by the particle velocities  $\vec{v}_{\ell a}$  and  $\vec{v}_{\ell h}$ , yields

$$\vec{v}_\ell = \vec{v}_{\ell a} + \vec{v}_{\ell h}, \quad (2.79)$$

$$\text{where } \vec{v}_{\ell a} \simeq \frac{-1}{\rho_0 c_0} \frac{\gamma \hat{\beta}}{\gamma - 1} \left[ \left( \frac{1}{c_0} \frac{\partial}{\partial t} \right)^{-1} + (\ell_v - \ell_h) \right] \text{grad } \tau_a,$$

$$\text{or } \vec{v}_{\ell a} \simeq \frac{-1}{\rho_0 c_0} \frac{\gamma \hat{\beta}}{\gamma - 1} \left( \frac{1}{c_0} \frac{\partial}{\partial t} \right)^{-1} \text{grad } \tau_a, \quad (2.79a)$$

$$\text{and } \vec{v}_{\ell h} \simeq \frac{\gamma \hat{\beta}}{\rho_0 c_0} \ell_h \text{grad } \tau_h, \quad (2.79b)$$

with  $(\partial/\partial t)^{-1}$  being the indefinite primitive with respect to the time. It must be emphasized that if the second-order factor  $\ell_h(\gamma-1)(\ell_v-\ell_h)\frac{1}{c_0}\frac{\partial}{\partial t}$  had been ignored in equation (2.75), the second terms of equation (2.78b) and (2.79b) would be null.

To summarize, solving equation (2.68) for  $\vec{v}_v$  (given equation (2.69a) and that  $\text{div } \vec{v}_v = 0$ ), then solving equation (2.76) and (2.77) for  $\tau_a$  and  $\tau_h$ , and reporting the resulting solutions into equations (2.78) and (2.79) for  $p$  and  $\vec{v}_\ell$  (given equation (2.69b) and  $\text{rot } \vec{v}_\ell = 0$ ) leads to the complete general solution to the basic linearized equations in dissipative fluids (2.65) to (2.69), away from the sources  $(q, h, \vec{F}_\ell + \vec{F}_v)$ , in the time domain, as long as the conditions for Navier-Stokes equation to be divided into two equations (2.67) and (2.68) are fulfilled.

In the frequency domain, or in other words here for a harmonic motion of the form  $e^{i\omega t}$  (i.e.  $\partial/\partial t = i\omega$  where  $\omega$  is the angular frequency of the wave), the previous argument is expressed as

$$\left(\Delta + k_v^2\right)\vec{v}_v = 0, \quad \text{with} \quad \text{div } \vec{v}_v = 0, \quad (2.80)$$

$$\left(\Delta + k_a^2\right)\tau_a = 0 \quad \text{and} \quad \left(\Delta + k_h^2\right)\tau_h = 0, \quad \text{with} \quad \tau = \tau_a + \tau_h, \quad (2.81)$$

$$p = p_a + p_h, \quad (2.82)$$

with

$$p_a \simeq \frac{\gamma\hat{\beta}}{\gamma-1}(1-ik_0\ell_h)\tau_a \simeq \frac{\gamma\hat{\beta}}{\gamma-1}\tau_a, \quad (2.82a)$$

and

$$p_h \approx i\gamma\hat{\beta}k_0(\ell_v-\ell_h)\tau_h \ll p_a, \quad (2.82b)$$

$$\vec{v}_\ell = \vec{v}_{\ell_a} + \vec{v}_{\ell_h}, \quad \text{rot } \vec{v}_\ell = \vec{0}, \quad (2.83)$$

with

$$\vec{v}_{\ell_a} \simeq \frac{i}{k_0\rho_0c_0}\frac{\gamma\hat{\beta}}{\gamma-1}[1+ik_0(\ell_v-\ell_h)]\text{grad } \tau_a,$$

$$\vec{v}_{\ell_h} \simeq \frac{i}{k_0\rho_0c_0}\frac{\gamma\hat{\beta}}{\gamma-1}\text{grad } \tau_a, \quad (2.83a)$$

and

$$\bar{v}_{\ell_h} \simeq \frac{\gamma \hat{\beta}}{\rho_0 c_0} \ell_h \text{ grad } \tau_h, \quad (2.83b)$$

$$\text{where } k_0 = \omega / c_0 \quad (2.84)$$

is characteristic of the source ( $\omega$ ) and the medium ( $c_0$ ),

$$k_v^2 = -ik_0 / \ell'_v = -i\rho_0 \omega / \mu \quad (2.85)$$

is the square of the viscous diffusion wavenumber,

$$k_a^2 \approx k_0^2 (1 - ik_0 \ell_{v_h}) \quad \text{with } \ell_{v_h} = \ell_v + (\gamma - 1)\ell_h \quad (2.86)$$

is the square of the acoustic wavenumber and

$$k_h^2 \simeq -\frac{ik_0}{\ell_h} [1 - ik_0(\gamma - 1)(\ell_v - \ell_h)] \simeq -\frac{ik_0}{\ell_h} \quad (2.87)$$

is the square of the thermal diffusion wavenumber, with

$$\ell_v = \frac{\eta + \frac{4}{3}\mu}{\rho_0 c_0} \quad \text{and} \quad \ell_h = \frac{\lambda}{\rho_0 c_0 C_p}.$$

Note: the imaginary part of  $k_a = k_0(1 - \frac{i}{2}k_0 \ell_{v_h})$  conveys the acoustic dissipation associated to viscosity and thermal conduction. It is convenient in many situations to consider the “classical” process of acoustic dissipation, proportional to the characteristic lengths  $\ell_v$  and  $\ell_h$ , therefore proportional to the viscosity coefficients  $\mu$  and  $\eta$ , as well as to the coefficient of thermal conductivity  $\lambda$ .

Moreover, the quantities  $\delta_v = \frac{\sqrt{2}}{|k_v|} = \sqrt{\frac{2\ell'_v}{k_0}}$  and  $\delta_h = \frac{\sqrt{2}}{|k_h|} = \sqrt{\frac{2\ell_h}{k_0}}$ , denoting the penetration depths (thickness of the viscous and thermal boundary layers, respectively), are in common use.

### 2.5.3. Approach of the solutions in presence of acoustic sources

The systems of equations obtained in the previous section are valid in the entire domain of propagation considered (finite or not), but only away from the sources. The derivation of the equations in presence of sources is rather lengthy, at least in

their exact form (which is less and less relevant as the experimental data do not contain any information on such small quantities). An example is given in the following paragraph.

In presence of acoustic sources of volume velocity ( $q$ ) and heat ( $h$ ), but away from any force source, equation (2.71), given the relationships (2.74) and (2.75), written for  $\vec{v}_\ell = \text{grad}\varphi$  (where  $\varphi$  is the velocity potential) can be expressed at the first order of the characteristic lengths as

$$\left[ \frac{1}{c_0} \frac{\partial}{\partial t} - \ell_h \Delta \right] \left( \left[ \frac{1}{c_0^2} \frac{\partial^2}{\partial t^2} - \left( 1 + \ell_{v_h} \frac{1}{c_0} \frac{\partial}{\partial t} \right) \Delta \right] \varphi - q \right) = \frac{\gamma-1}{c_0^2} \frac{1}{c_0} \frac{\partial}{\partial t} h. \quad (2.88)$$

This expression underlines the respective roles of the sources of volume velocity and heat. Away from any source of heat ( $h$ ), this equation is reduced to a classical equation of propagation

$$\left[ \frac{1}{c_0^2} \frac{\partial^2}{\partial t^2} - \left( 1 + \ell_{v_h} \frac{1}{c_0} \frac{\partial}{\partial t} \right) \Delta \right] \varphi = q. \quad (2.89)$$

The comparison of equation (2.88) with (2.89) shows that the former, satisfied by the velocity potential in presence of sources of volume velocity and heat, can be decomposed into two equations, one for the heat diffusion,

$$\left( \frac{1}{c_0} \frac{\partial}{\partial t} - \ell_h \Delta \right) Q_h = \frac{\gamma-1}{c_0^2} \frac{1}{c_0} \frac{\partial}{\partial t} h, \quad (2.90)$$

and one equation of acoustic propagation,

$$\left[ \frac{1}{c_0^2} \frac{\partial^2}{\partial t^2} - \left( 1 + \ell_{v_h} \frac{1}{c_0} \frac{\partial}{\partial t} \right) \Delta \right] \varphi = q + Q_h, \quad (2.91)$$

where  $\varphi$  results from the superposition of an acoustic field  $\varphi_a$  and an entropic field  $\varphi_h$  ( $\varphi = \varphi_a + \varphi_h$ ). These equations are part of the domain of equations of “classical” diffusion (2.90) and “classical” propagation (2.91).

#### 2.5.4. Boundary conditions

In the time domain, boundary conditions include the initial conditions, related to the scalar fields (pressure or temperature) and vectorial fields (particle velocities)

and to the first derivative with respect to time of the acoustic quantities (the time operators are of second order in the propagation equations); also included are the boundary conditions that one must consider in the frequency domain which more often depend on the considered frequency.

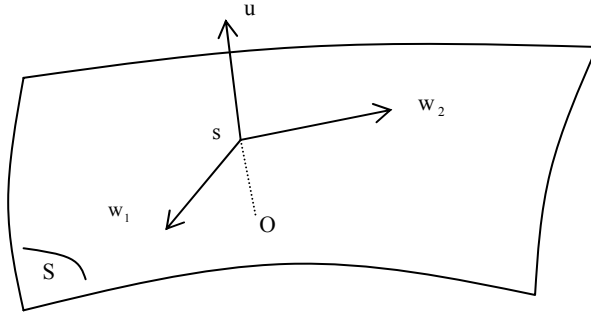

**Figure 2.8.** *Coordinate system used at the frontiers of the considered domain*

To express these boundary conditions, the following notations are adopted: a point of the interface (the boundary) between the domain of propagation considered and the exterior domain is localized in a system of coordinates such that the outward normal coordinate is noted  $u$  and the tangential coordinates are noted  $w_1$  and  $w_2$  (Figure 2.8). For example, for a cylindrical boundary the set  $(u, w_1, w_2)$  represents the set  $(r, \theta, z)$ . The intersection of the axis  $\bar{u}$  with the wall is noted “ $s$ ” (for a cylinder,  $u = s$  is written  $u = R$ , where  $R$  is the radius of the cylinder). There are three boundary conditions related to the temperature variation  $\tau$ , the normal component of the total particle velocity at the boundary and on its tangential component (the wall is assumed motionless). The law of continuity of the stresses at the interface fluid/wall is not yet introduced as it does not provide any useful information in this context; it only introduces the wall reaction, which is of no interest since the coupling fluid/wall is not considered here (rigid wall).

#### 2.5.4.1. *Thermal boundary conditions (frequency domain)*

The acoustic perturbation is associated with a temperature variation  $\tau$  in the fluid that is responsible for a heat transfer from the fluid to the boundary (often a solid). The heat flow is positive along the  $u$  axis (outwardly directed) if  $\tau$  is positive and is an inverse heat flow if  $\tau$  is negative. The resulting perturbation of the acoustic wave takes the form of attenuation due to dissipation of the thermal energy. This heat transfer is governed by three laws presented in the following three paragraphs.

i) The law of continuity of the heat flow at the interface  $u = s$ ,

$$\lambda \frac{\partial \tau}{\partial s} = \lambda_f \frac{\partial \tau_f}{\partial s}, \quad (2.92)$$

where  $\lambda_f$  and  $\tau_f$  represent respectively the coefficient of thermal conduction of the wall and the temperature difference in the wall and where  $\frac{\partial \tau}{\partial s}$  is actually  $\left. \frac{\partial \tau}{\partial u} \right)_{u=s}$ .

Note: the notation “s” does not refer to the acoustic entropy in section 2.5.4.

ii) The classical equation of diffusion of heat in the wall,

$$[\Delta_u - i\omega\rho_f C_f / \lambda_f] \tau_f(u) = 0, \quad (2.93)$$

where the quantity of heat per unit of mass  $dQ_f$  received by the wall is expressed as a function of the density  $\rho_f$  and of the specific heat capacity  $C_f$  of the wall by  $dQ_f = \rho_f C_f dT_f$ , and where  $\Delta_u = \frac{d^2}{dx^2}$  in Cartesian coordinates,  $\frac{1}{r^2} \frac{\partial}{\partial r} \left( r^2 \frac{\partial}{\partial r} \right)$  in spherical coordinates and  $\frac{\partial^2}{\partial r^2} + \frac{1}{r} \frac{\partial}{\partial r}$  in cylindrical coordinates.

This equation assumes the generally verified hypothesis that the heat flow parallel to the interface is negligible due to a relatively small temperature gradient in this direction (the acoustic wavelength is great compared to the thickness of the boundary layers).

In practice, and most often in the case of capillary tubes, the radius of curvature of the boundary satisfies the inequality

$$R \gg \sqrt{\frac{\lambda_f}{\omega\rho_f C_f}},$$

so that equation (2.93) can be approximated, regardless of the coordinate system, to

$$\left[ \frac{d^2}{du^2} - i\omega \frac{\rho_f C_f}{\lambda_f} \right] \tau_f(u) = 0. \quad (2.94)$$



The harmonic solution to equation (2.94) for diffusion along the  $\bar{u}$  axis,

$$\tau_f = e^{-\sqrt{i\omega\rho_f C_f / \lambda_f} u} e^{i\omega t}, \quad (2.95)$$

precisely satisfies the differential equation

$$\left[ \frac{d}{du} + \sqrt{i\omega\rho_f C_f / \lambda_f} \right] \tau_f = 0. \quad (2.96)$$

iii) The temperatures of the fluid  $\tau(u, \bar{w})$  and of the wall  $\tau_f(u, \bar{w})$  are equal at the interface  $u = s$ , for any point  $\bar{w}(w_1, w_2)$ ,

$$\tau_f(s, \bar{w}) = \tau(s, \bar{w}). \quad (2.97)$$

Reporting equation (2.96) into equation (2.92) and considering equation (2.97) leads to the boundary condition on the temperature variation of the fluid

$$\left[ 1 + L_h \frac{\partial}{\partial s} \right] \tau(s, \bar{w}) = 0, \quad \forall \bar{w} = (w_1, w_2), \quad (2.98)$$

with  $L_h = \lambda / \sqrt{i\omega\rho_f C_f \lambda_f}$ . This condition is of the mixed homogeneous type associated with an equivalent ‘‘impedance’’ of a wall  $Z_h = ik_0\rho_0 c_0 L_h$ .

Assuming a solution with separated variables for  $\tau = \tau_a + \tau_h$ ,

$$\begin{aligned} \tau_a(u, \bar{w}) &= \hat{\tau}_a(k_{au} u) \psi_a(\bar{k}_{aw} \cdot \bar{w}) \\ \text{and } \tau_h(u, \bar{w}) &= \hat{\tau}_h(k_{hu} u) \psi_h(\bar{k}_{hw} \cdot \bar{w}) \end{aligned} \quad (2.99)$$

additionally, given that the boundary condition must be verified for all points  $\bar{w}(w_1, w_2)$  on the boundary, one obtains

$$\psi_a(\bar{k}_{aw} \cdot \bar{w}) = \psi_h(\bar{k}_{hw} \cdot \bar{w}), \quad \forall \bar{w}. \quad (2.100)$$

The functions  $\psi_a$  and  $\psi_h$  will now be referred to as  $\psi(\bar{k}_{aw} \cdot \bar{w})$ . The boundary condition (2.98) can then be written as

$$\left( 1 + L_h \frac{\partial}{\partial s} \right) \hat{\tau}(k_{au} s) = - \left( 1 + L_h \frac{\partial}{\partial s} \right) \hat{\tau}_h(k_{hu} s), \quad (2.101)$$

with  $k_{au}^2 = k_a^2 - k_{aw}^2$  and  $k_{hu}^2 = k_h^2 - k_{hw}^2$  where the square of the wavenumbers  $k_a^2$  and  $k_h^2$  are given by the equations (2.86) and (2.87).

For most applications, the product of the heat capacity  $C_f$  of the wall by its thermal conductivity  $\lambda_f$  is significantly greater than its equivalent product for the fluid. Consequently, the factor  $L_h \partial / \partial s$  can be ignored and equations (2.98) and (2.101) become:

$$\begin{aligned} \tau(s, \vec{w}) &= 0, \quad \tau_a(s, \vec{w}) = -\tau_h(s, \vec{w}), \quad \forall \vec{w}, \\ \text{or } \hat{\tau}_a(k_{\text{aus}}) &= -\hat{\tau}_h(k_{\text{hus}}). \end{aligned} \quad (2.102)$$

Equation (2.102) is a commonly-used form of boundary condition. It leads to the following note: while the entropic temperature  $\tau_h$  (associated with the heat diffusion) is negligible compared to the acoustic temperature  $\tau_a$  within the fluid – meaning at a closest distance from the wall greater than the length of thermal diffusion, that is, away from the thermal boundary layers of thickness  $\delta_h = \sqrt{2\ell_h / k_0}$ , between 500 $\mu\text{m}$  and 10 $\mu\text{m}$  for the air in normal conditions between 20Hz and 20kHz – these two temperature differences have equal absolute values ( $\tau_a = -\tau_h$ ) at the immediate vicinity of the boundary.

The dissipative phenomena are therefore more important at the boundary of the domain than in the bulk of the fluid (a similar note can be formulated regarding the phenomena associated to viscosity). Actually, a non-negligible heat wave is generated on the wall by heat transfer between the incident acoustic wave and the wall that penetrates the medium via a diffusion process (very small velocity  $c_h$  and very high attenuation  $\Gamma_h = 1/\delta_h$ ). It is easy to verify the above statement by writing that

$$k_h = \frac{\omega}{c_h} - i\Gamma_h,$$

with, according to equation (2.87),

$$k_h = \frac{1-i}{\sqrt{2}} \sqrt{\frac{k_0}{\ell_h}}, \quad c_h = \sqrt{2\omega\ell_h c_0} \ll c_0 \quad (\text{in the audible range})$$

$$\text{and } \Gamma_h = \sqrt{k_0 / (2\ell_h)} \gg k_0.$$

#### 2.5.4.2. Boundary conditions on the particle velocity

The boundary conditions on the particle velocity  $\vec{v} = \vec{v}_{\ell_a} + \vec{v}_{\ell_h} + \vec{v}_v$  assume a very small tangential motion, proportional to the normal derivative of the tangential component given by

$$\left(1 + \zeta_{\vec{w}} \frac{\partial}{\partial s}\right) \vec{v}_{\vec{w}}(s, \vec{w}) = \vec{0}, \quad \forall \vec{w}, \quad (2.103)$$

and a motion normal to the wall, written in terms of specific wall impedance

$$\left(1 + \zeta_u \frac{\partial}{\partial s}\right) v_u(s, \vec{w}) = 0, \quad \forall \vec{w}, \quad (2.104)$$

where, assuming as a first approximation Euler's equation  $\rho_0 \frac{\partial}{\partial t} v_u = -\frac{\partial}{\partial u} p$ , the latter can be written

$$i k_0 \rho_0 c_0 \zeta_u = \frac{p}{v_u}, \quad (\partial / \partial t = i \omega). \quad (2.105)$$

In most applications, the walls are smooth and rigid, consequently the parameters  $\zeta_u$  and  $\zeta_{\vec{w}}$  are very close to zero and the conditions (2.103) and (2.104) become

$$v_u(s, \vec{w}) = 0, \quad \vec{v}_{\vec{w}}(s, \vec{w}) = \vec{0}, \quad \forall \vec{w}.$$

When one is considering equations (2.83),

$$v_{\ell_a} \simeq \frac{i}{k_0 \rho_0 c_0} \frac{\gamma \hat{\beta}}{\gamma - 1} \text{grad } \tau_a, \quad v_{\ell_h} \simeq \frac{\gamma \hat{\beta}}{\rho_0 c_0} \ell_h \text{grad } \tau_h, \quad (2.106)$$

and writing the solution for the particle velocity as a function of the separable variables ( $s$  and  $\vec{w}$ ), equations (2.106) become

$$\frac{i}{k_0 \rho_0 c_0} \frac{\gamma \hat{\beta}}{\gamma - 1} \left[ \frac{\partial}{\partial s} \hat{\tau}_a(k_{au}s) - i(\gamma - 1) k_0 \ell_h \frac{\partial}{\partial s} \hat{\tau}_h(k_{hu}s) \right] \psi(\vec{k}_{aw} \cdot \vec{w}) \quad (2.107)$$

$$= -\hat{v}_{vu}(k_{vu}s) \psi_{vu}(\vec{k}_{vw} \cdot \vec{w}),$$

$$\frac{i}{k_0 \rho_0 c_0} \frac{\gamma \hat{\beta}}{\gamma - 1} [\hat{\tau}_a(k_{au}s) - i(\gamma - 1) k_0 \ell_h \hat{\tau}_h(k_{hu}s)] \vec{\nabla}_{\vec{w}} \psi(\vec{k}_{aw} \cdot \vec{w}) \quad (2.108)$$

$$= -\hat{v}_{v\vec{w}}(k_{vu}s) \vec{\Phi}_{v\vec{w}}(\vec{k}_{vw} \cdot \vec{w}),$$

where the right-hand side terms represent respectively, apart from the sign, the normal and tangential components of the vortical velocity. Since these equations must be satisfied for any point  $\vec{w}$  on the boundary

$$\psi_{vu}(\vec{k}_{vw} \cdot \vec{w}) = \psi(\vec{k}_{aw} \cdot \vec{w}) \quad \text{and} \quad \vec{\Phi}_{v\vec{w}}(\vec{k}_{vw} \cdot \vec{w}) = \vec{\nabla}_{\vec{w}} \psi(\vec{k}_{aw} \cdot \vec{w}) \quad (2.109)$$

implying that  $\hat{v}_{v\vec{w}}(k_{vu}s)$  is independent of  $\vec{w}$ , thus

$$\hat{v}_{vw_1}(k_{vu}s) = \hat{v}_{vw_2}(k_{vu}s), \quad (2.110)$$

(velocity component noted  $\hat{v}_{vw}(k_{vu}s)$  below),

and that  $k_{vu}^2 = k_v^2 - k_{aw}^2$ , where  $k_v^2$  is given by equation (2.85).

By substituting the boundary equations (2.107) and (2.108) into one another and given equations (2.102), (2.109) and (2.110), this leads to the boundary equation

$$\begin{aligned} [1 + i(\gamma - 1)k_0 \ell_h] \frac{\hat{v}_{vu}(k_{vu}s)}{\hat{v}_{vw}(k_{vu}s)} &= \frac{1}{\hat{\tau}_a(k_{au}s)} \frac{\partial}{\partial s} \hat{\tau}_a(k_{au}s) \\ &+ i(\gamma - 1)k_0 \ell_h \frac{1}{\hat{\tau}_h(k_{hu}s)} \frac{\partial}{\partial s} \hat{\tau}_h(k_{hu}s). \end{aligned} \quad (2.111)$$

$\hat{v}$  and  $\hat{v}$  are dimensionally different, given equations (2.109), (2.107) and (2.108).

Note 1: since each type of motion (acoustic, entropic and vortical) depends similarly on  $\vec{w}$  via the function  $\psi(k_{aw} \cdot \vec{w})$ , the acoustic, entropic and vortical wavenumbers (respectively  $k_a$ ,  $k_h$  and  $k_v$ ) satisfy the relationships

$$k_a^2 = k_{au}^2 + k_{aw}^2, \quad k_h^2 = k_{hu}^2 + k_{aw}^2, \quad k_v^2 = k_{vu}^2 + k_{aw}^2, \quad (2.112)$$

where  $k_a^2$ ,  $k_h^2$  and  $k_v^2$  are given by equations (2.85) to (2.87) and where  $k_{au}$  and  $k_{aw}$  are given by the considered wave front (examples are given in the following chapter).

Note 2: similarly to heat waves, the vortical waves obey a diffusion process in the boundary layers of thickness  $\delta_v = \sqrt{2\ell'_v/k_0}$  at the vicinity of the wall. They are generated by viscous friction of the incident acoustic wave on the wall and penetrate the medium following a diffusion process (very small velocity  $c_v$  and very high attenuation  $\Gamma_v = 1/\delta_v$ ). It is easy to verify the above statement by writing that

$$k_v = \frac{\omega}{c_v} - i\Gamma_v,$$

with, according to the equation (2.85),

$$k_v = \frac{1-i}{\sqrt{2}} \sqrt{\frac{k_0}{\ell'_v}}, \quad c_v = \sqrt{2\omega\ell'_v}c_0 \ll c_0 \quad \text{and} \quad \Gamma_v = \sqrt{k_0/(2\ell'_v)} \gg k_0.$$

The vortical velocity is actually a shear velocity. A schematic representation is given in Figure 1.1; it corresponds to a transverse wave.

## Chapter 2: Appendix

# Equations of Continuity and Equations at the Thermomechanic Discontinuities in Continuous Media

The equations presented in the two previous chapters are here derived in the wider context of fluid mechanics. The objective of this appendix is to familiarize the reader with a broader approach, which completes the previous presentations.

### A.1. Introduction

#### A.1.1. *Material derivative of volume integrals*

Let  $\bar{I}(t)$  be the function defined by an integral over a regular domain  $D(t)$  delimited by the surface  $\partial D$  along the motion of the considered fluid,

$$\bar{I}(t) = \iiint_{D(t)} \bar{K}(\vec{r}, t) dD,$$

where  $\bar{K}(\vec{r}, t)$  is a continuous function (vectorial or not) derivable in the domain  $(D)$ . By denoting  $\vec{v}$  the fluid velocity field, the material derivative of this integral is given by

$$\begin{aligned}
 d_t \bar{I} &= d_t \iiint_D \bar{K} dD, \\
 &= \iiint_D [\partial_t \bar{K} + \partial_j (\bar{K} v_j)] dD, \\
 &= \iiint_D [d_t \bar{K} + \bar{K} \cdot \text{div } \bar{v}] dD, \\
 &= \iiint_D \partial_t \bar{K} dD + \iint_{\partial D} \bar{K} (\bar{v} \cdot d\bar{\Sigma})
 \end{aligned}
 \tag{2.113}$$

where  $\partial D$  denotes the surface delimiting the domain (D) and  $d\bar{\Sigma}$  is a surface element orientated outward from the considered domain. The derivation of these results can be detailed as follows.

If  $M^0(\bar{r}^0)$  is, at the initial time  $t_0$ , the equivalent to the point  $M(\bar{r})$  at the instant  $t$ , there exists only one way to express the corresponding coordinates  $x_i$  as functions of the coordinates  $x_i^0$

$$x_i = G_i(x_1^0, x_2^0, x_3^0, t),
 \tag{2.114a}$$

that is generally written as

$$x_i = x_i(x_1^0, x_2^0, x_3^0, t).
 \tag{2.114b}$$

If  $J$  denotes the determinant of the matrix of coefficients  $\left(\partial_{x_j^0} x_i\right)$ , called the functional determinant (or Jacobian) and noted

$$J = \det\left(\partial_{x_j^0} x_i\right) = \frac{D(x_1, x_2, x_3)}{D(x_1^0, x_2^0, x_3^0)},
 \tag{2.115}$$

then it is possible to write

$$d_t \bar{I} = d_t \iiint_D \bar{K} dD = d_t \iiint_{D_0} \bar{K} J dD_0 = \partial_t \iiint_{D_0} \bar{K} J dD_0,
 \tag{2.116a}$$

where  $D_0$  is the considered domain at the time  $t_0$  and where  $J$  and  $\bar{K}$  are functions of  $x_i^0$  and  $t$ . When  $t$  varies, the domain  $D_0$  remains unchanged and equation (2.116a) becomes

$$d_t \bar{I} = \iiint_{D_0} \partial_t (\bar{K} J) dD_0 = \iiint_{D_0} (\bar{K} \partial_t J + J \partial_t \bar{K}) dD_0.
 \tag{2.116b}$$

However, according to the rule of determinant differentiation (resulting from the corresponding rule for composed functions) and considering the following definition of the velocity

$$\partial_t \bar{x} \left( x_i^0, t \right) = \bar{v}, \quad (2.117)$$

one obtains

$$\begin{aligned} \frac{\partial J}{\partial t} &= \frac{\partial}{\partial t} \left[ \frac{D(x_1, x_2, x_3)}{D(x_1^0, x_2^0, x_3^0)} \right], \\ &= \frac{D(v_1, x_2, x_3)}{D(x_1^0, x_2^0, x_3^0)} + \frac{D(x_1, v_2, x_3)}{D(x_1^0, x_2^0, x_3^0)} + \frac{D(x_1, x_2, v_3)}{D(x_1^0, x_2^0, x_3^0)}, \end{aligned}$$

that is

$$\frac{\partial J}{\partial t} = \frac{D(x_1, x_2, x_3)}{D(x_1^0, x_2^0, x_3^0)} \left[ \frac{D(v_1, x_2, x_3)}{D(x_1, x_2, x_3)} + \dots \right],$$

or, using the relationship,

$$\left[ \frac{D(v_1, x_2, x_3)}{D(x_1, x_2, x_3)} \right] = \frac{\partial v_1}{\partial x_1}, \quad (2.118)$$

$$\frac{\partial J}{\partial t} = J \left( \frac{\partial v_1}{\partial x_1} + \frac{\partial v_2}{\partial x_2} + \frac{\partial v_3}{\partial x_3} \right) = J \operatorname{div} \bar{v}. \quad (2.119)$$

Reporting equation (2.119) into equation (2.116b) yields

$$d_t \bar{I} = \iiint_{D_0} \left( \partial_t \bar{K} + \bar{K} \operatorname{div} \bar{v} \right) J dD_0, \quad \text{where } \bar{K} = \bar{K}(x_i^0, t), \quad (2.120)$$

or, using the variables  $(x, t)$  and reporting equation (2.115) written as  $J dD_0 = dD$ ,

$$d_t \bar{I} = \iiint_{D(t)} \left( d_t \bar{K} + \bar{K} \operatorname{div} \bar{v} \right) dD, \quad \text{with } \bar{K} = \bar{K}(x_i, t). \quad (2.121)$$

Equations (2.113) can be obtained from equation (2.121) by noting that

$$d_t \bar{K} = \partial_t \bar{K} + \bar{v} \cdot \operatorname{grad} \bar{K},$$



thus

$$d_t \bar{K} + \bar{K} \operatorname{div} \bar{v} = \partial_t \bar{K} + \partial_j (\bar{K} v_j),$$

and, by applying Ostrogradsky's formula

$$\iiint_D \partial_j (\bar{K} v_j) dD = \iint_{\partial D} \bar{K} (\bar{v} \cdot d\bar{\Sigma}).$$

### A.1.2. Generalization

One can generalize the previous discussion. Let  $(\partial D)$  be a closed surface delimiting a domain  $(D)$  in motion and  $\bar{w}(M, t)$  the velocity of a point  $M$  of  $(\partial D)$  at the time  $t$ . The velocity field  $\bar{w}(M, t)$  is assumed different from the fluid velocity field  $\bar{v}(M, t)$  such that  $(\partial D)$  is not a surface followed by any particular motion.

Note: in this appendix, the notations  $\bar{u}$  and  $\bar{w}$  do not represent the same quantities as the ones denoted similarly in Chapter 2.

From a mathematical point of view, calculating this derivative is equivalent to calculating the material derivative. Indeed, replacing in the previous results the terms  $d_t$  (respectively  $\bar{v}$ ) by  $\delta_t$  (respectively  $\bar{w}$ ) where  $\delta_t$  denotes the derivative with respect to the time obtained by following a point along its respective path defined by  $\bar{w}$ , one obtains, for example,

$$\delta_t = \partial_t + \bar{w} \cdot \operatorname{grad}, \tag{2.122}$$

and for a volume integral

$$\delta_t \iiint_D \bar{K} dD = \iiint_D \partial_t \bar{K} dD + \iint_{\partial D} \bar{K} (\bar{w} \cdot d\bar{\Sigma}). \tag{2.123}$$

The introduction of the relative velocity  $\bar{u}$  of the media with respect to the proper motion  $\bar{w}$

$$\bar{u} = \bar{v} - \bar{w}, \tag{2.124}$$

leads to the explicit relationship between the two operators  $d_t$  and  $\delta_t$

$$d_t = \delta_t + \bar{u} \cdot \operatorname{grad}, \tag{2.125}$$

$$d_t \iiint_D \bar{K} dD = \delta_t \iiint_D \bar{K} dD + \iint_{\partial D} \bar{K} (\bar{u} \cdot d\bar{\Sigma}), \tag{2.126}$$

where  $D$  denotes then the domain following the fluid in motion  $\bar{\mathbf{v}}$  and  $d_t$ , the material derivative that follows the same motion.

In the particular case where  $\bar{\mathbf{w}} = \bar{\mathbf{0}}$ , the operator  $\delta_t$  is nothing more than the partial derivative  $\partial_t$  corresponding to a motionless point in the associated coordinate system. Then  $\bar{\mathbf{v}} = \bar{\mathbf{u}}$  and equations (2.125) and (2.126) can be written (as was previously established) as

$$d_t = \partial_t + \bar{\mathbf{v}} \cdot \text{grad} \ , \quad (2.127)$$

$$d_t \iiint_D \bar{\mathbf{K}} dD = \iiint_D \partial_t \bar{\mathbf{K}} dD + \iint_{\partial D} \bar{\mathbf{K}} (\bar{\mathbf{v}} \cdot d\bar{\Sigma}) \ . \quad (2.128)$$

## A.2. Equations of continuity

### A.2.1. Mass conservation equation

According to equations (2.113), the expression of the mass conservation law (1.26), taken away from any sources,

$$d_t \iiint_{D(t)} \rho dD = 0$$

can also be written as

$$\begin{aligned} \iiint_D [\partial_t \rho + \text{div}(\rho \bar{\mathbf{v}})] dD &= 0 \ , \\ \iiint_D [d_t \rho + \rho \text{div} \bar{\mathbf{v}}] dD &= 0 \ , \\ \iiint_D \partial_t \rho dD + \iint_{\partial D} \rho \bar{\mathbf{v}} \cdot d\bar{\Sigma} &= 0 \ , \end{aligned} \quad (2.129)$$

or, if  $\delta_t$  defines the derivative with respect to the time calculated at a moving point  $\bar{\mathbf{w}}$ , as

$$\delta_t \iiint_D \rho dD + \iint_{\partial D} \rho (\bar{\mathbf{v}} - \bar{\mathbf{w}}) \cdot d\bar{\Sigma} = 0 \ . \quad (2.130)$$

The velocity field  $(\bar{\mathbf{v}} - \bar{\mathbf{w}})$  defines the relative velocity of the media (fluid velocity) with respect to the proper motion used for the calculation of the time derivative.

The presence of sources, characterized by their volume velocity in the domain  $D(t)$  does not affect the previous results, thus verifying equations (1.27) to (1.30) of the mass conservation law obtained in Chapter 1.

### A.2.2. Equation of impulse continuity

According to equations (2.21) and (2.22), the fundamental equation of dynamics for an arbitrary domain (D) can be written as

$$\iiint_D \rho d_t \vec{v} dD = \iiint_D \left[ \rho \vec{F} + \text{div} \vec{\sigma} \right] dD, \quad (2.131)$$

the action of external sources inside the domain (D) being characterized here by the force  $\rho \vec{F}$  per unit of volume.

By adding the null quantity  $\iiint_D \vec{v} (d_t \rho + \rho \text{div} \vec{v}) dD$  to the left-hand side term of this equation (of mass conservation away from any volume velocity sources), one obtains

$$\iiint_D \left[ \rho d_t \vec{v} + \vec{v} d_t \rho + \rho \vec{v} \text{div} \vec{v} \right] dD = \iiint_D \left[ \rho \vec{F} + \text{div} \vec{\sigma} \right] dD,$$

thus,

$$\iiint_D \left[ d_t (\rho \vec{v}) + \rho \vec{v} \text{div} \vec{v} \right] dD = \iiint_D \left[ \rho \vec{F} + \text{div} \vec{\sigma} \right] dD.$$

According to equations (2.113), the above result can be written in the following forms

$$d_t \iiint_{D(t)} \rho \vec{v} dD = \iiint_{D(t)} \left[ \rho \vec{F} + \text{div} \vec{\sigma} \right] dD, \quad (2.132a)$$

$$\iiint_{D(t)} \left[ \partial_t (\rho \vec{v}) + \partial_{x_j} (\rho \vec{v} v_j) \right] dD = \iiint_{D(t)} \left[ \rho \vec{F} + \text{div} \vec{\sigma} \right] dD. \quad (2.132b)$$

Equation (2.132b) includes a summation over all values of  $j$  and can also be written as

$$\partial_t (\rho \vec{v}) + \partial_{x_j} (\rho \vec{v} v_j) = \rho \vec{F} + \text{div} \vec{\sigma}, \quad (2.132c)$$

$$\iiint_{D(t)} \partial_t (\rho \vec{v}) dD + \iint_{\partial D} (\rho \vec{v}) (\vec{v} \cdot d\vec{\Sigma}) = \iiint_{D(t)} \left[ \rho \vec{F} + \text{div} \vec{\sigma} \right] dD, \quad (2.132d)$$

$$\delta_t \iiint_{D(t)} \rho \vec{v} dD + \iint_{\partial D} (\rho \vec{v}) [(\vec{v} - \vec{w}) \cdot d\vec{\Sigma}] = \iiint_{D(t)} \left[ \rho \vec{F} + \text{div} \vec{\sigma} \right] dD. \quad (2.132e)$$

These are the equations of conservation of the impulse  $\rho \vec{v}$  : the total variation of impulse in  $D(t)$  is equal to the contribution of the bulk sources  $\rho \vec{F}$  and the surfaces reactions  $\left( \text{div} \vec{\sigma} \right)$ .

### A.2.3. Equation of entropy continuity

The equation of heat propagation is written (equations (2.40) and (2.43)) as

$$\rho T \partial_t S = \text{div}(\lambda \text{grad} T) + \mathfrak{T}_{ij} \partial_{x_j} v_i + \rho h \quad (\text{sum over } j),$$

or

$$\rho T (\partial_t S + \vec{v} \cdot \text{grad} S) = \text{div}(\lambda \text{grad} T) + \mathfrak{T}_{ij} \partial_{x_j} v_i + \rho h.$$

If one multiplies the equation of mass conservation (away from any sources) by the entropy function  $S$  and adds the result to the above equations, one obtains respectively

$$\rho \partial_t S + \rho \vec{v} \cdot \text{grad} S + S \partial_t \rho + S \text{div}(\rho \vec{v}) = \frac{1}{T} \left[ \text{div}(\lambda \text{grad} T) + \mathfrak{T}_{ij} \partial_{x_j} v_i + \rho h \right]$$

or

$$\partial_t (\rho S) + \text{div}(\rho S \vec{v}) = \frac{1}{T} \left[ \text{div}(\lambda \text{grad} T) + \mathfrak{T}_{ij} \partial_{x_j} v_i + \rho h \right]. \quad (2.133)$$

This constitutes the local form of the equation of entropy conservation per unit of volume ( $\rho S$ ). The various integral equivalents can be derived following a similar approach.

### A.2.4. Equation of energy continuity

This equation is not a complement, but the consequence of the previous results. It is seldom used because of its difficult implementation.

The variation per unit of time of the total energy per unit of volume is the sum of the variation of kinetic energy ( $\rho v^2 / 2$ ) and of internal (potential) energy ( $\rho \varepsilon$ )

$$\partial_t E = \partial_t \left( \frac{\rho v^2}{2} + \rho \varepsilon \right). \quad (2.134)$$

Given that  $2\bar{v} \cdot (\bar{v} \cdot \text{grad} \bar{v}) = \bar{v} \cdot \text{grad} v^2$ , the set of equations (2.34) to (2.35) leads to

$$\begin{aligned} \partial_t \left( \frac{\rho v^2}{2} \right) = & \left[ -\frac{v^2}{2} \text{div}(\rho \bar{v}) - \rho \bar{v} \cdot \text{grad} \frac{v^2}{2} - \bar{v} \cdot \text{grad} p \right] \\ & + \left[ \text{div}(\bar{v} \cdot \bar{\mathfrak{T}}) - \mathfrak{T}_{ij} \partial_{x_j} v_i \right] + \bar{v} \cdot \rho \bar{F} + \rho q \frac{v^2}{2}. \end{aligned} \quad (2.135)$$

This equation can be interpreted as follows: the variation per unit of time of the kinetic energy per unit of volume  $\partial_t(\rho v^2/2)$  is the sum of three terms; one term associated with the phenomena independent of the viscosity and external sources; one associated with the variations of kinetic energy due to the viscosity; and finally one that introduces the effects of external sources.

Also, reporting the quantities  $\rho T \partial_t S$  derived from the expressions of mass and entropy conservation into equation (2.38), which is written as

$$\partial_t(\rho \varepsilon) = \left( \frac{P}{\rho} + \varepsilon \right) \partial_t \rho + \rho T \partial_t S, \quad (2.136)$$

yields

$$\begin{aligned} \partial_t(\rho \varepsilon) = & - \left( \frac{P}{\rho} + \varepsilon \right) \text{div}(\rho \bar{v}) - \rho T \bar{v} \cdot \text{grad} S \\ & + \text{div}(\lambda \text{grad} T) + \mathfrak{T}_{ij} \partial_{x_j} v_i + \rho h. \end{aligned} \quad (2.137)$$

Given that

$$dH = TdS + \frac{1}{\rho} dP \quad \text{and therefore that } T \text{grad} S = \text{grad} \left( \frac{P}{\rho} + \varepsilon \right) - \frac{1}{\rho} \text{grad} p,$$

equation (2.137) becomes

$$\begin{aligned} \partial_t(\rho \varepsilon) = & \left[ - \left( \frac{P}{\rho} + \varepsilon \right) \text{div}(\rho \bar{v}) + \bar{v} \cdot \text{grad} p - \rho \bar{v} \cdot \text{grad} \left( \frac{P}{\rho} + \varepsilon \right) \right] \\ & + \text{div}(\lambda \text{grad} T) + \mathfrak{T}_{ij} \partial_{x_j} v_i + \rho h. \end{aligned} \quad (2.138)$$

Equation (2.138) can be interpreted as follows: the variation per unit of time of the potential energy per unit of volume  $\partial_t(\rho \varepsilon)$  is the sum of three terms; one term associated with the phenomena independent of the viscosity and thermal conduction;

one associated with the variations of internal energy due to thermal conduction (factor  $\lambda$ ); and finally one term introducing the conversion of kinetic energy into heat (internal energy) due to the viscosity (factor containing the tensor  $\overline{\overline{\mathfrak{S}}}$ ).

The variation per unit of time of the total energy per unit of volume of fluid is thus given by equations (2.135) to (2.138) as

$$\begin{aligned} \partial_t E = \partial_t \left( \rho \frac{v^2}{2} + \rho \varepsilon \right) = & \left[ - \left( \frac{P}{\rho} + \varepsilon + \frac{v^2}{2} \right) \operatorname{div}(\rho \vec{v}) - \rho \vec{v} \cdot \operatorname{grad} \left( \frac{P}{\rho} + \varepsilon + \frac{v^2}{2} \right) \right] \\ & + \left[ \operatorname{div}(\lambda \operatorname{grad} T) + \operatorname{div}(\vec{v} \cdot \overline{\overline{\mathfrak{S}}}) \right] + \vec{v} \cdot \rho \vec{F} + \rho q \frac{v^2}{2} + \rho h, \end{aligned} \quad (2.139)$$

or

$$\begin{aligned} \partial_t \left( \rho \frac{v^2}{2} + \rho \varepsilon \right) + \operatorname{div} \left[ \left( \rho \frac{v^2}{2} + \rho \varepsilon \right) \vec{v} \right] \\ = \operatorname{div} \left( -P \vec{v} + \lambda \operatorname{grad} T + \vec{v} \cdot \overline{\overline{\mathfrak{S}}} \right) + \rho \left[ \vec{F} \cdot \vec{v} + q \frac{v^2}{2} + h \right]. \end{aligned} \quad (2.140)$$

It is the local form of the equation of conservation of total energy  $\rho[(v^2/2) + \rho\varepsilon]$ .

Among the many possible equivalent integrals over the domain  $D(t)$ , one leads directly to the variation of total energy due to the contributions from the external sources contained in the domain and from the energy transfers with the exterior at the boundaries, due to pressure forces, thermal conduction and viscosity related forces

$$\begin{aligned} d_t \iiint_{D(t)} \left( \rho \frac{v^2}{2} + \rho \varepsilon \right) dD = \iiint_{D(t)} \rho \left[ \vec{F} \cdot \vec{v} + q \frac{v^2}{2} + h \right] dD \\ + \iint_{\partial D} \left( -P \vec{v} + \lambda \operatorname{grad} T + \vec{v} \cdot \overline{\overline{\mathfrak{S}}} \right) \cdot d\vec{\Sigma}. \end{aligned} \quad (2.141)$$

Note: the considered motions in this appendix involve both the “acoustic” and “non-acoustic” components and are not in any way linearized.

### A.3. Equations at discontinuities in mechanics

#### A.3.1. Introduction

The velocity field  $\vec{v}$  and the quantity  $\vec{K}$  (2.113), involved in this equation of conservation, can be considered continuous within a surface of discontinuity  $\Sigma$ . This discontinuity can be induced, for example, by an interface between two media of different nature.

The domain ( $D$ ) is then divided into two sub-domains  $D_1$  and  $D_2$  by the surface of discontinuity  $\Sigma$ , each domain  $D_i$  being delimited by the surface  $\partial D_i = \Sigma + S_i$ , with  $i = 1, 2$  (Figure 2.9).

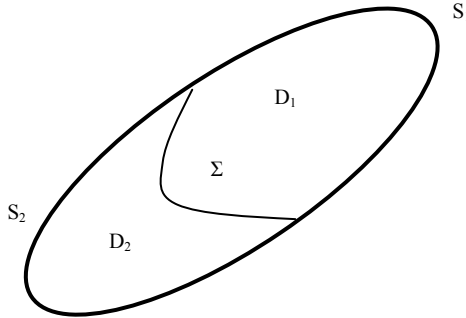

**Figure 2.9.** Surface of discontinuity dividing a domain  $D$  into two sub-domains  $D_1$  and  $D_2$

By denoting  $\vec{w}(M, t)$  the velocity of a point  $M$  of the previously defined surfaces and assuming  $\vec{w} \neq \vec{v}$  for any point  $M \in \Sigma$ , and  $\vec{w} = \vec{v}$  for  $M \in S_i$  where  $\vec{v}(M, t)$  is the fluid velocity, it is then possible to write

$$d_t \iiint_D \vec{K} dD = \delta_t \iiint_{D_1} \vec{K} dD + \delta_t \iiint_{D_2} \vec{K} dD, \tag{2.142}$$

where the derivatives with respect to the time are estimated along the path of the point  $M$  of motion  $\vec{W}$  that coincides with the motion of the surfaces delimiting each of the considered volumes.

By denoting  $\vec{K}_{(i)}$ , respectively  $\vec{v}_{(i)}$ , the value taken at  $M \in \Sigma$  by the quantity  $\vec{K} \in D_i$ , respectively  $\vec{v} \in D_i$ , and  $d\vec{\Sigma}_{(i)}$  the outward element of surface  $\Sigma$  of the domain  $D_i$ , equation (2.123) becomes

$$\delta_t \iiint_{D_1} \vec{K} dD = \iiint_{D_1} \partial_t \vec{K} dD + \iint_{S_1 + \Sigma} \vec{K}_{(1)} (\vec{w} \cdot d\vec{\Sigma}_{(1)}). \tag{2.143}$$

Adding and subtracting the same term in the right-hand site of equation (2.143) yields

$$\begin{aligned} \delta_t \iiint_{D_i} \bar{\mathbf{K}} dD = & \iiint_{D_i} \partial_t \bar{\mathbf{K}} dD - \iint_{S_i+\Sigma} \bar{\mathbf{K}}_{(i)} [(\bar{\mathbf{v}}_{(i)} - \bar{\mathbf{w}}) \cdot d\bar{\Sigma}_{(i)}] \\ & + \iint_{S_i+\Sigma} \bar{\mathbf{K}}_{(i)} [\bar{\mathbf{v}}_{(i)} \cdot d\bar{\Sigma}_{(i)}]. \end{aligned} \quad (2.144)$$

Noting that  $(\bar{\mathbf{v}}_{(i)} - \bar{\mathbf{w}}) = \bar{\mathbf{0}}$  on  $S_i$ , by hypothesis, and applying the theorem of divergence, equation (2.144) becomes

$$\begin{aligned} \delta_t \iiint_{D_i} \bar{\mathbf{K}} dD = & \iiint_{D_i} \partial_t \bar{\mathbf{K}} dD \\ & - \iint_{\Sigma} \bar{\mathbf{K}}_{(i)} [\bar{\mathbf{v}}_{(i)} - \bar{\mathbf{w}} \cdot d\bar{\Sigma}_{(i)}] \\ & + \iiint_{D_i} \partial_{x_j} [\bar{\mathbf{K}} v_j] dD. \end{aligned}$$

The sum over all values of  $i$  ( $i=1,2$ ) leads to the following relationship that includes a sum over  $j$

$$d_t \iiint_D \bar{\mathbf{K}} dD = \iiint_D [\partial_t \bar{\mathbf{K}} + \partial_j (\bar{\mathbf{K}} v_j)] dD + \iint_{\Sigma} [\bar{\mathbf{K}} u_j] d\Sigma_j, \quad (2.145)$$

where, denoting  $d\bar{\Sigma} = d\bar{\Sigma}_1 - d\bar{\Sigma}_2$ , and  $[[\cdot]] = (\cdot)_2 - (\cdot)_1$ ,

$$\begin{aligned} & - \bar{\mathbf{K}}_{(2)} [(\bar{\mathbf{v}}_{(2)} - \bar{\mathbf{w}}) \cdot d\bar{\Sigma}_{(2)}] - \bar{\mathbf{K}}_{(1)} [(\bar{\mathbf{v}}_{(1)} - \bar{\mathbf{w}}) \cdot d\bar{\Sigma}_{(1)}] \\ & = \bar{\mathbf{K}}_{(2)} [(\bar{\mathbf{v}}_{(2)} - \bar{\mathbf{w}}) \cdot d\bar{\Sigma}] - \bar{\mathbf{K}}_{(1)} [(\bar{\mathbf{v}}_{(1)} - \bar{\mathbf{w}}) \cdot d\bar{\Sigma}], \\ & = [[\bar{\mathbf{K}} (v_j - w_j)]] d\Sigma_j, \\ & = [[\bar{\mathbf{K}} u_j]] d\Sigma_j. \end{aligned}$$

The comparison of this result with equation (2.113) shows that the presence of the discontinuity surface introduces an additional surface integral in the expression of the particle derivative of a volume integral.

### A.3.2. Application to the equation of impulse conservation

If one starts from equation (2.132b) of the equation of impulse continuity

$$d_t \iiint_D \rho \bar{\mathbf{v}} dD = \iiint_D \rho \bar{\mathbf{F}} dD + \iint_{\partial D} \bar{\bar{\sigma}} \cdot d\bar{\Sigma},$$



and replaces the left-hand side term by its expression given by equation (2.145) where  $\bar{\mathbf{K}}$  is replaced by  $\rho \bar{\mathbf{v}}$ , one obtains

$$\iint_{\partial D} \left[ \partial_t (\rho \bar{\mathbf{v}}) + \partial_{x_j} (\rho \bar{\mathbf{v}} v_j) - \rho \bar{\mathbf{F}} \right] dD + \iint_{\Sigma} \left[ \rho \bar{\mathbf{v}} u_j \right] d\Sigma_j - \iint_{\partial D} \bar{\bar{\sigma}} \cdot d\bar{\Sigma} = \bar{\mathbf{0}}. \quad (2.146)$$

Given the following relationships

$$\begin{aligned} \iint_{\partial D} \bar{\bar{\sigma}} \cdot d\bar{\Sigma} &= \iint_{S_1} \bar{\bar{\sigma}} \cdot d\bar{\Sigma} + \iint_{S_2} \bar{\bar{\sigma}} \cdot d\bar{\Sigma}, \\ \iint_{\partial D} \bar{\bar{\sigma}} \cdot d\bar{\Sigma} &= \iint_{S_1 + \Sigma} \bar{\bar{\sigma}}(1) \cdot d\bar{\Sigma} + \iint_{S_2 + \Sigma} \bar{\bar{\sigma}}(2) \cdot d\bar{\Sigma} + \iint_{\Sigma} \left[ \bar{\bar{\sigma}} \right] \cdot d\bar{\Sigma}, \\ \iint_{\partial D} \bar{\bar{\sigma}} \cdot d\bar{\Sigma} &= \iint_{D_1} \operatorname{div} \bar{\bar{\sigma}} dD + \iint_{D_2} \operatorname{div} \bar{\bar{\sigma}} dD + \iint_{\Sigma} \left[ \bar{\bar{\sigma}} \right] \cdot d\bar{\Sigma}, \end{aligned}$$

where by definition (equation 2.145),

$$\left[ \bar{\bar{\sigma}} \right] \cdot d\bar{\Sigma} = - \left[ \bar{\bar{\sigma}}(2) \cdot d\bar{\Sigma}(2) + \bar{\bar{\sigma}}(1) \cdot d\bar{\Sigma}(1) \right] = \left[ \bar{\bar{\sigma}}(2) - \bar{\bar{\sigma}}(1) \right] \cdot d\bar{\Sigma}(1),$$

equation (2.146) yields, decomposing the integral over  $D$  into two integrals over  $D_1$  and  $D_2$

$$\iint_{D_1 + D_2} \left[ \partial_t (\rho \bar{\mathbf{v}}) + \partial_{x_j} (\rho \bar{\mathbf{v}} v_j) - \operatorname{div} \bar{\bar{\sigma}} - \rho \bar{\mathbf{F}} \right] dD + \iint_{\Sigma} \left[ \rho \bar{\mathbf{v}} \otimes \bar{\mathbf{u}} - \bar{\bar{\sigma}} \right] \cdot d\bar{\Sigma} = \bar{\mathbf{0}}, \quad (2.147)$$

where the notation  $\rho \bar{\mathbf{v}} \otimes \bar{\mathbf{u}} \cdot d\bar{\Sigma}$  is simply the product of the scalar  $\bar{\mathbf{u}} \cdot d\bar{\Sigma}$  by the vector  $\rho \bar{\mathbf{v}}$ , otherwise written  $\rho \bar{\mathbf{v}} u_j d\Sigma_j$  with a summation over  $j$ .

The term in brackets in the volume integral is null (local law (2.132c) of impulse continuity in each domain  $D_1$  and  $D_2$ ), thus

$$\iint_{\Sigma} \left[ \rho \bar{\mathbf{v}} \otimes \bar{\mathbf{u}} - \bar{\bar{\sigma}} \right] \cdot d\bar{\Sigma} = \bar{\mathbf{0}}. \quad (2.148)$$

Therefore, denoting

$$\begin{aligned} \bar{\mathbf{n}} &= d\bar{\Sigma} / d\Sigma, \\ \bar{\bar{\varphi}}(i) &= \left[ \rho \bar{\mathbf{v}}(i) \otimes \bar{\mathbf{u}}(i) - \bar{\bar{\sigma}}(i) \right] \cdot \bar{\mathbf{n}}, \\ \bar{\bar{\varphi}} &= \bar{\bar{\varphi}}(2) - \bar{\bar{\varphi}}(1), \end{aligned}$$

equation (2.148) becomes

$$\iint_{\Sigma} \bar{\varphi} d\Sigma = \bar{\mathbf{0}}, \quad \forall \Sigma,$$

where  $\bar{\varphi}$  is a continuous function. One can show that this result implies  $\bar{\varphi} = \bar{\mathbf{0}}$  by letting  $M_0$  be a point on  $\Sigma$  and  $\varphi_i(M_0)$  the positive component of the vectorial function  $\bar{\varphi}(M_0)$ . The function  $\varphi_i(M)$  being continuous, there exist a set of points close to  $M_0$  such that

$$\varphi_i(M) > \frac{1}{2} \varphi_i(M_0), \quad \forall M \in (s), \quad i = 1, 2, 3$$

and such that

$$\iint_{(s)} \varphi_i(M) d\Sigma > \frac{\text{area}(s)}{2} \varphi_i(M_0) \neq \bar{\mathbf{0}}.$$

This statement contradicts the initial equation verified in particular for  $(\Sigma)$  coinciding with  $(s)$ . Thus,  $\bar{\varphi} = \bar{\mathbf{0}}$ .

Finally, the condition (2.148) at the discontinuity surface can be written as

$$\rho_{(1)} \bar{v}_{(1)} [\bar{u}_{(1)} \cdot \bar{n}] - \bar{\sigma}_{(1)} \cdot \bar{n} = \rho_{(2)} \bar{v}_{(2)} [\bar{u}_{(2)} \cdot \bar{n}] - \bar{\sigma}_{(2)} \cdot \bar{n}, \quad (2.149)$$

where  $\bar{u}$  is the fluid velocity relative to the discontinuity surface ( $\bar{u} = \bar{v} - \bar{w}$ ).

By denoting  $\bar{u}_{(i)n} = \bar{u}_{(i)} \cdot \bar{n}$ , the normal fluid velocity relative to the discontinuity surface (the normal  $\bar{n}$  being orientated from medium 1 toward medium 2) and by writing that  $\bar{\sigma} \cdot \bar{n} = \bar{T}(\bar{n})$  (equation 2.20), the condition at the discontinuity becomes

$$\rho_{(1)} \bar{v}_{(1)} u_{(1)n} - \bar{T}_{(1)}(\bar{n}) = \rho_{(2)} \bar{v}_{(2)} u_{(2)n} - \bar{T}_{(2)}(\bar{n}),$$

or

$$\llbracket \rho \bar{v} u_n - \bar{T} \rrbracket = \bar{\mathbf{0}}. \quad (2.150)$$

Note: if  $\bar{\mathfrak{S}} = 0$ ,  $\sigma_{ij} = p\delta_{ij}$  and  $\bar{T}(\bar{n}) = -p\bar{n}$ , equation (2.150) can be written

$$\llbracket \rho \bar{v} u_n + p\bar{n} \rrbracket = \bar{\mathbf{0}}. \quad (2.151)$$

### A.3.3. Other conditions at discontinuities

One can obtain, by analogy, the equations of mass, entropy and energy conservation.

The mass conservation law leads to

$$\llbracket \rho u_n \rrbracket = 0; \quad (2.152)$$

the entropy conservation law (for an adiabatic motion) leads to

$$\llbracket \rho TS u_n \rrbracket = 0; \quad (2.153)$$

the energy conservation law (for an adiabatic motion) leads to

$$\llbracket \left[ \left( \rho \frac{v^2}{2} + \rho \varepsilon \right) u_n - (\bar{\sigma} \cdot \bar{v}) \cdot \bar{n} \right] \rrbracket = 0, \quad (2.154)$$

$$\text{with } \bar{\sigma} \cdot \bar{v} = \bar{\mathfrak{S}} \cdot \bar{v} - p \bar{v} \text{ and } \bar{\sigma} \cdot \bar{v} \cdot \bar{n} = \bar{\mathfrak{T}} \cdot \bar{v}.$$

Note 1: by denoting  $m = \rho u_n$ , these equations can be written

$$\text{– for the mass conservation, } \llbracket m \rrbracket = 0, (m_1 = m_2 = m); \quad (2.155a)$$

$$\text{– for the moment, } m \llbracket \bar{v} \rrbracket = \llbracket \bar{\mathfrak{T}} \rrbracket; \quad (2.155b)$$

$$\text{– for the energy, } m \llbracket \left[ \frac{v^2}{2} + \varepsilon \right] \rrbracket = \llbracket \bar{\mathfrak{T}} \cdot \bar{v} \rrbracket; \quad (2.155c)$$

$$\text{– for the entropy, } m \llbracket TS \rrbracket = 0. \quad (2.155d)$$

Note 2: all the above equations contain information required when applying the equations of conservation to a given domain with a discontinuity surface. They are necessary, but not always sufficient, particularly in the case of viscous fluids (see the following section).

### A.4. Examples of application of the equations at discontinuities in mechanics: interface conditions

The number of available equations is such that one can find the solutions, the equations of impulse, mass and entropy conservation, and the equations demonstrating that mass density and entropy are state-functions. These equations are all partial differential equations and the solutions depend on arbitrarily chosen

functions. Obtaining the solutions for these types of problems lies on the boundary conditions they must satisfy. The conditions at discontinuities can be taken as boundary conditions to obtain the solution to a problem of continuous motion within one of the media. To these boundary conditions, one can add the initial conditions, in the time domain, that can be written at each point  $M$  of the domain (including its boundary) as

$$\rho(M, t = 0) = a(M), \quad \vec{v}(M, 0) = \vec{b}(M), \quad p(M, 0) = c(M). \quad (2.156)$$

The following section derives these boundary conditions.

#### **A.4.1. Interface solid – viscous fluid**

The surface of the solid is assumed to be animated by a motion of local normal velocity  $w(M, t)$ . At the discontinuity between medium (1) and medium (2), equation (2.152) gives

$$\rho_{(1)}[v_{(1)n} - w] = \rho_{(2)}[v_{(2)n} - w]. \quad (2.157)$$

Since fluid and solid are not mixing together, one can write that the flow of mass at the interface between the two media is equal to zero. Thus

$$\rho_{(1)}[v_{(1)n} - w] = \rho_{(2)}[v_{(2)n} - w] = 0,$$

implying continuity of the normal velocity at the interface

$$v_{(1)n} = v_{(2)n} = w. \quad (2.158)$$

Moreover, equation (2.150) suggests that

$$\rho_{(1)}\vec{v}_{(1)}[v_{(1)n} - w] - \vec{T}_{(1)} = \rho_{(2)}\vec{v}_{(2)}[v_{(2)n} - w] - \vec{T}_{(2)},$$

which, combined with equation (2.158), leads to the expression of strain continuity at the interface

$$\vec{T}_{(1)} = \vec{T}_{(2)}, \quad (2.159)$$

and therefore to the continuity of the tangential velocities

$$v_{(1)t} = v_{(2)t}.$$

The conditions at this interface are actually given by two equations (2.158) and (2.159) expressing the continuity of normal and tangential velocities.

In the case of a solid at rest, these equations become

$$v_{(1)n} = v_{(2)n} = w = 0 \text{ and } \vec{T}_{(1)} = \vec{T}_{(2)}. \quad (2.160)$$

In the case of a non-viscous fluid, they are

$$v_{(1)n} = v_{(2)n} = w \text{ and } \vec{T}_{(1)} = -p\vec{n}. \quad (2.161)$$

The laws that were accepted in the previous chapter (because they seemed obvious) are not fundamentally justified.

#### **A.4.2. Interface between perfect fluids**

Equation (2.152) yields

$$\begin{aligned} \rho_{(1)}u_{(1)n} &= \rho_{(2)}u_{(2)n}, \\ \text{with } u_n &= (\vec{v} - \vec{w}) \cdot \vec{n}. \end{aligned} \quad (2.162)$$

If the relative fluid velocity  $\vec{u}_n$ , about the direction  $\vec{n}$  normal to the interface, is non-null – meaning that the particles are free to go from one side of the interface to the other (a shock wave, for example) – then, substituting expression (1.161) of  $\vec{T}$  into equation  $[[\rho \vec{v} u_n - \vec{T}]] = \vec{0}$  leads to

$$\begin{aligned} [[p\vec{n} + \rho\vec{v}u_n]] &= \vec{0}, \\ \text{or } p_{(1)}\vec{n} + \rho_{(1)}\vec{v}_{(1)}u_{(1)n} &= p_{(2)}\vec{n} + \rho_{(2)}\vec{v}_{(2)}u_{(2)n}. \end{aligned}$$

Subtracting the equal quantities  $\rho_{(1)}u_{(1)}\vec{w}$  and  $\rho_{(2)}u_{(2)}\vec{w}$  in, respectively, the left- and right-hand side terms leads to

$$[[p\vec{n} + \rho\vec{u}u_n]] = \vec{0}. \quad (2.163)$$

About the normal direction, equation (2.163) becomes

$$[[p + \rho u_n^2]] = 0,$$

and, about the tangential direction, is

$$[[\rho u_n u_t]] = 0.$$

In the particular case where  $u_{(1)n} = u_{(2)n} = 0$ ,  $[[p]] = 0$ , but  $[[u_t]]$  is assumed non-null. The surface of discontinuity is, in such a case, called the surface of contact.

#### ***A.4.3. Interface between two non-miscible fluids in motion***

The equation at discontinuity can be written, making use of the same argumentation as in section A.4, as

$$w = v_{(1)n} = v_{(2)n} \quad \text{and} \quad \vec{T}_{(1)} = \vec{T}_{(2)},$$

and, for a perfect fluid, as

$$P_{(1)} = P_{(2)}.$$

Note: further developments are required in order to completely express the conditions of transfer at the interface related to purely acoustic perturbations.

*This page intentionally left blank*

## Chapter 3

# Problems of Acoustics in Dissipative Fluids

### 3.1. Introduction

The methods presented in Chapter 2 are of great importance. It is important to complete the discussion by applying these methods in few examples of acoustic propagation in dissipative fluids. This chapter is entirely dedicated to this.

In addition, this chapter offers the opportunity to study few “classical” problems of acoustics and to introduce important notions and results commonly referred to in practice and throughout this book. The discussions and situations analyzed in all the following chapters will therefore consider the dissipation due to the visco-thermal effects, and sometimes due to the molecular relaxation. Specific conditions on the homogeneity of the fluids, the linearity of the motion, etc. will be considered according to the problem at hand.

The study of acoustic fields in three different domains is presented herein: in a semi-infinite space (or in a very large closed space when compared to the wavelengths considered), in small closed spaces and finally in infinite spaces.

### 3.2. Reflection of a harmonic wave from a rigid plane

#### 3.2.1. *Reflection of an incident harmonic plane wave*

Let a semi-infinite fluid medium be limited by an infinite rigid plane of equation  $y = 0$  (Figure 3.1), the  $y$ -axis being orientated positive in the fluid direction.



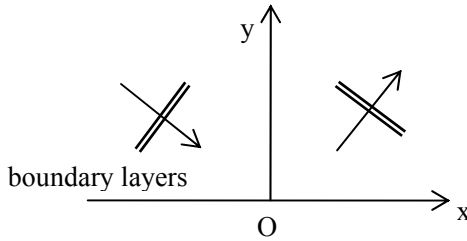

**Figure 3.1.** An incident harmonic plane wave is reflected by a rigid plane on  $y = 0$ , entropic and vortical waves are generated within the boundary layers

The plane defined by the direction of the incident harmonic plane wave and the axis  $\vec{O}y$  normal to the rigid plane coincides, by convention, with the  $xOy$  plane so that the considered problem can be treated in two dimensions. The interaction between the incident wave and the rigid wall generates in a diffused entropic wave, a diffused vortical wave (shear motion) and a reflected acoustic wave. The diffused waves remain within the very thin boundary layers of the wall.

The objective of this study is to show that the thermal and viscosity effects at the boundary  $y=0$  can be modeled using the concept of specific admittance  $(\rho_0 c_0 / Z_a)$ , which is a function of the coefficient of shear viscosity and thermal conductivity, defined as such that the reflection of an acoustic wave from a rigid wall in a visco-thermal fluid presents the same characteristics as that from a wall of impedance  $Z_a$  in a non-dissipative fluid.

The problem considered is defined by the system of differential equations (2.80) to (2.87) in the domain  $y > 0$ , with which are associated the boundary conditions:  $\tau = 0$  (2.102) and  $\vec{v} = \vec{0}$  (2.106) at  $y = 0, \forall x$ . The function  $\psi$  (2.100) is chosen in the form  $e^{-ik_x x}$ , so that the temperature difference is written (the time factor  $e^{i\omega t}$  being suppressed throughout) as

$$\tau = \tau^+ + \tau^- = \left( \tau_a^+ + \tau_h^+ \right) + \left( \tau_a^- + \tau_h^- \right), \tag{3.1}$$

where  $\tau^+$  represents the incident wave,

$$\tau^+ = \left[ e^{ik_{ay}y} + A_h^+ e^{ik_{hy}y} \right] e^{-ik_x x} \simeq e^{ik_{ay}y} e^{-ik_x x},$$

and  $\tau^-$  represents the reflected wave,

$$\tau^- = \left[ R_a e^{-ik_{ay}y} + A_h^- e^{-ik_{hy}y} \right] e^{-ik_x x}.$$

All amplitudes considered in the problem are normalized to the amplitude of the incident acoustic temperature and subsequently set equal to the unit. The amplitude of the incident thermal wave  $A_h^+$  is ignored when compared with the incident acoustic wave. However, this assumption cannot be made for the reflected wave since, at the interface,  $\tau_a = -\tau_h$ , the factor  $R_a$  denotes the reflection coefficient for the acoustic wave which absolute value for which remains inferior to one. The wavenumbers satisfy the following equations (2.112):

$$k_a^2 = k_x^2 + k_{ay}^2 \quad \text{and} \quad k_h^2 = k_x^2 + k_{hy}^2, \quad (3.2)$$

where the quantities are projected onto the  $x$ - and  $y$ -directions, the vectors  $k_a$  and  $k_h$  being given by equations (2.86) and (2.87).

The solution for the laminar particle velocity is the superposition of an incident (+) and a reflected (-) wave,

$$\bar{v}_\ell = \left( \bar{v}_{\ell a}^+ + \bar{v}_{\ell h}^+ \right) + \left( \bar{v}_{\ell a}^- + \bar{v}_{\ell h}^- \right), \quad (3.3)$$

$$\text{with } v_{\ell x}^\pm = -ik_x \left[ \frac{i}{k_0 \rho_0 c_0} \frac{\gamma \hat{\beta}}{\gamma - 1} \tau_a^\pm + \frac{\gamma \hat{\beta}}{\rho_0 c_0} \ell_h \tau_h^\pm \right], \quad (3.3a)$$

$$\text{and } v_{\ell y}^\pm = \pm \left[ ik_{ay} \frac{i}{k_0 \rho_0 c_0} \frac{\gamma \hat{\beta}}{\gamma - 1} \tau_a^\pm + ik_{hy} \frac{\gamma \hat{\beta}}{\rho_0 c_0} \ell_h \tau_h^\pm \right]. \quad (3.3b)$$

A similar form of solution is considered for the vortical velocity,

$$\bar{v}_v = \bar{v}_v^+ + \bar{v}_v^-, \quad (3.4)$$

$$\text{with } v_{vx}^\pm = \pm A_v^\pm \frac{k_{vy}}{k_x} e^{\pm ik_{vy}y} e^{-ik_x x}, \quad (3.4a)$$

$$\text{and } v_{vy}^\pm = A_v^\pm e^{\pm ik_{vy}y} e^{-ik_x x} \quad \text{with } k_v^2 = k_x^2 + k_{vy}^2. \quad (3.4b)$$

The incident vortical wave  $\bar{v}_v^+$  is negligible compared with the reflected vortical wave  $\bar{v}_v^-$  generated at the wall.

The boundary conditions at  $y=0$  on the temperature variation and on the components of the particle velocity (parallel and normal to the  $y=0$  plane) are

$$1 + R_a + A_h^- = 0, \quad (3.5)$$

$$(1+R_a) \frac{k_x}{k_0} \frac{1}{\rho_0 c_0} \frac{\gamma \hat{\beta}}{\gamma-1} - i A_h^- \frac{\gamma \hat{\beta}}{\rho_0 c_0} k_x \ell_h - A_v^- \frac{k_{vy}}{k_x} = 0, \quad (3.6)$$

$$- \frac{k_{ay}}{k_0} \frac{1}{\rho_0 c_0} \frac{\gamma \hat{\beta}}{\gamma-1} (1-R_a) - i A_h^- \frac{\gamma \hat{\beta}}{\rho_0 c_0} k_{hy} \ell_h + A_v^- = 0. \quad (3.7)$$

These three conditions lead, by elimination of the parameters  $A_h^-$  and  $A_v^-$ , to

$$-i(\gamma-1)k_0 \ell_h (1+R_a)(k_x^2 + k_{hy}k_{vy}) = (k_x^2 + k_{vy}k_{ay})R_a - (k_{vy}k_{ay} - k_x^2), \quad (3.8)$$

or, considering equations (3.2) and (3.4b) where  $k_x \ll k_{hy}$  and  $k_x \ll k_{vy}$ , to

$$k_{hy} = \sqrt{\frac{-ik_0}{\ell_h} - k_x^2} \approx \sqrt{\frac{-ik_0}{\ell_h}}, \quad k_{vy} = \sqrt{\frac{-ik_0}{\ell'_h} - k_x^2} \approx \sqrt{\frac{-ik_0}{\ell'_h}} \quad \text{and,} \\ k_{ay} \frac{1-R_a}{1+R_a} = \sqrt{ik_0} k_0 \left[ \left( 1 - \frac{k_{ay}^2}{k_a^2} \right) \sqrt{\ell'_v} + (\gamma-1) \sqrt{\ell_h} \right], \quad (3.9)$$

where  $\sqrt{i} = (1+i)/\sqrt{2}$  since the real part of  $(1-R_a)$  is positive.

The equivalent specific admittance (mentioned at the beginning of the chapter), defined as

$$\frac{\rho_0 c_0}{Z_a} = -\rho_0 c_0 \frac{v_{ay}}{p_a} \approx \frac{\frac{1}{\rho_0 c_0} \frac{\gamma \hat{\beta}}{\gamma-1} \frac{k_{ay}}{k_0} (1-R_a)}{\frac{\gamma \hat{\beta}}{\gamma-1} (1+R_a)},$$

can be written, considering equation (3.9), as

$$\frac{\rho_0 c_0}{Z_a} \approx \frac{1+i}{\sqrt{2}} \sqrt{k_0} \left[ \left( 1 - \frac{k_{ay}^2}{k_a^2} \right) \sqrt{\ell'_v} + (\gamma-1) \sqrt{\ell_h} \right]. \quad (3.10)$$

The factor  $(1-k_{ay}^2/k_a^2)$  is nothing more than the square of the sine of the incidence angle; it is equal to zero in normal incidence and to one in grazing incidence. It translates the effect of shear viscosity at the boundary ( $\sqrt{\ell'_v}$ ), null when the particle velocity is normal to the wall and maximum when parallel to the wall, whereas the entropic coefficient  $(\gamma-1)\sqrt{\ell_h}$ , related to the scalar pressure and temperature, is independent of the incidence.

Note that equation (3.8), and consequently (3.10), can be directly obtained by substituting the forms of equation (3.1) to (3.4) into equation (2.111), leading to

$$\left[1 + i(\gamma - 1)k_0 \ell_h\right] \frac{ik_x^2}{k_{vy}} = \frac{ik_{ay}(1 - R_a)}{1 + R_a} + (\gamma - 1)k_0 \ell_h k_{hy} \text{ etc.} \quad (3.11)$$

### 3.2.2. Reflection of a harmonic acoustic wave

Equation (3.10), obtained for the reflection of a plane harmonic wave, can be applied in a much wider context, as will be demonstrated here. The following derivations are based on the relationships imposed by the equation of propagation of  $\tau_a$  (2.81) that are

$$\frac{\partial^2}{\partial x^2} \psi(k_x x, k_z z) = -k_x^2 \psi \quad \text{and} \quad \frac{\partial^2}{\partial z^2} \psi = -k_z^2 \psi,$$

with  $k_a^2 = k_{ay}^2 + k_x^2 + k_z^2$ .

Ignoring  $k_x$  and  $k_z$  ( $k_z, k_x < k_a \ll k_h$ ), equation (2.81),  $(\Delta + k_h^2)\tau_h = 0$ , leads to

$$\left[\frac{\partial^2}{\partial y^2} + (k_h^2 - k_x^2 - k_z^2)\right] \tau_h = 0 \quad \text{then to} \quad \left(\frac{\partial^2}{\partial y^2} + k_h^2\right) \tau_h \approx 0. \quad (3.12)$$

Equation (3.12), written in the form

$$\left(\frac{\partial}{\partial y} - ik_h\right) \left(\frac{\partial}{\partial y} + ik_h\right) \tau_h = 0, \quad (3.13)$$

and the fact that the thermal incident wave is negligible compared to the wave generated at the boundary, leads to the conclusion that only the  $\tau_h^-$  wave is to be considered. It is the solution to

$$\left(\frac{\partial}{\partial y} + ik_h\right) \tau_h = 0. \quad (3.14)$$

Equation (3.14) leads directly, considering equation (2.99), to the expression of the thermal wave generated at the boundary  $z = 0$

$$-\frac{1}{\hat{\tau}_h} \frac{\partial}{\partial y} \hat{\tau}_h \approx i \sqrt{\frac{-ik_0}{\ell_h}}. \quad (3.15)$$

Similarly, the shear wave (vortical motion  $\vec{v}_v$ ) “entering” the fluid from the boundary is the solution to equation (2.80)

$$\left[ \frac{\partial^2}{\partial y^2} + (k_v^2 - k_x^2 - k_z^2) \right] v_{vy} = 0, \quad (3.16)$$

and presents, similarly to the thermal wave, the following property:

$$-\frac{1}{v_{vy}} \frac{\partial}{\partial y} v_{vy} = -\sqrt{k_v^2 - k_x^2 - k_z^2} \approx ik_v \sqrt{\frac{-ik_0}{\ell'_v}}. \quad (3.17)$$

According to equations (2.107) to (2.110), equation (2.80) can be written as

$$\begin{aligned} \operatorname{div} \vec{v}_v &= \frac{\partial}{\partial y} \hat{v}_{vy}(k_{vy}y) \psi(k_x x, k_z z) + \frac{\partial}{\partial x} \left[ \hat{v}_{vx}(k_{vy}y) \frac{\partial}{\partial x} \psi(k_x x, k_z z) \right] \\ &\quad + \frac{\partial}{\partial z} \left[ \hat{v}_{vz}(k_{vy}y) \frac{\partial}{\partial z} \psi(k_x x, k_z z) \right] = 0, \\ \text{or } \frac{\partial}{\partial y} \hat{v}_{vy}(k_{vy}y) &= k_x^2 \hat{v}_{vx}(k_{vy}y) + k_z^2 \hat{v}_{vz}(k_{vy}y). \end{aligned} \quad (3.18)$$

The substitution of equation (3.17) into equation (3.18) and combining the result with equation (2.110), equivalent to  $\hat{v}_{vx}|_{y=0} = \hat{v}_{vz}|_{y=0} = \hat{v}_{vw}$ , leads to

$$\frac{\hat{v}_{vy}(0)}{\hat{v}_{vw}(0)} \simeq i\sqrt{i} \sqrt{\frac{\ell'_v}{k_0}} k_0^2 \left( 1 - \frac{k_{ay}^2}{k_a^2} \right), \quad (3.19a)$$

$$\text{since } k_x^2 + k_z^2 = k_a^2 - k_{ay}^2 = k_a^2 \left( 1 - \frac{k_{ay}^2}{k_a^2} \right) \approx k_0^2 \left( 1 - \frac{k_{ay}^2}{k_a^2} \right). \quad (3.19b)$$

Finally, equations (2.82) and (2.83) yield

$$\frac{1}{\tau_a} \frac{\partial}{\partial y} \tau_a \approx -ik_0 \rho_0 c_0 \frac{v_{\ell a}|_y}{p_a} = \frac{ik_0 \rho_0 c_0}{Z_a}. \quad (3.20)$$

Combining equations (3.17), (3.19), (3.20) and (2.111) leads to the same equation (3.10) derived at an order of half a characteristic length without making any assumption as to the nature of the incident wave profile.

Note: the equivalent specific admittance of the wall is proportional to the square root of the characteristics lengths  $\sqrt{\ell'_v}$  and  $\sqrt{\ell_h}$ , whereas the visco-thermal

effects are linearly dependent on the characteristic lengths in the dissipation factor during the propagation  $k_a = k_0 \left( 1 - \frac{i}{2} k_0 \ell_{vh} \right)$  (2.86). This highlights the importance of the vortical and entropic phenomena at the vicinity of the wall  $\left( \sqrt{\ell'_v}, \sqrt{\ell'_h} \gg \ell'_v, \ell'_h \right)$ , due to much higher particle velocity and acoustic temperature gradients at the vicinity of the wall than in the bulk of the fluid.

As noted at the end of section 2.5.2, these phenomena occur within thin layers of fluid near the boundary; the layers are called the viscous boundary layer (of thickness  $\delta_v \approx \frac{\sqrt{2}}{|k_v|} = \sqrt{\frac{2\ell'_v}{k_0}}$ ) and thermal boundary layer (of thickness  $\delta_h \approx \frac{\sqrt{2}}{|k_h|} = \sqrt{\frac{2\ell'_h}{k_0}}$ ).

It is the localization of the viscous and thermal phenomena at the immediate vicinity of the wall that leads to the introduction of equivalent wall impedance in domains the dimensions of which are much greater than the thickness of the boundary layers. Outside these boundary layers, the vortical and entropic velocities are negligible compared to the total acoustic velocity. Moreover, within the viscous boundary layers, the shear effects overwhelm the effects of the bulk viscosity, justifying there the absence of a second viscosity coefficient in equation (3.10).

Note: the solutions to equations (2.80) to (2.87), in a space limited by a rigid spherical surface of radius  $R$ , take the forms

$$\hat{\tau}_a = j_n(k_a r), \quad \hat{\tau}_h = j_n(k_h r), \quad \psi = Y_{nm}(\theta, \varphi), \quad (3.21)$$

where  $j_n$  is the  $n^{\text{th}}$  order spherical Bessel's function and where the functions  $Y_{nm}$  are harmonic spherical functions (see Chapter 4), and

$$\hat{v}_{vr} = B \frac{1}{r} j_n(k_v r), \quad \hat{v}_{v\theta} = \hat{v}_{v\varphi} = \frac{B}{n(n+1)} \frac{\partial}{\partial r} [r j_n(k_v r)], \quad (3.22)$$

$$\text{with } B = -n(n+1) \frac{i}{k_0 \rho_0 c_0} \frac{\gamma \hat{\beta}}{\gamma - 1} \frac{[1 - i(\gamma - 1)k_0 \ell_h] j_n(k_a R)}{\frac{\partial}{\partial R} [R j_n(k_v R)]}.$$

The substitution of equation (3.22) into equation (2.111) gives the wavenumber  $k_a$  and the resonance frequencies of the spherical rigid resonator.

In the particular case of a cylindrical resonator of main axis  $\vec{Oz}$ , the solutions can be written as

$$\hat{\tau}_a = J_m\left(\sqrt{k_a^2 - k_{az}^2} r\right), \quad \hat{\tau}_h = J_m\left(\sqrt{k_h^2 - k_{az}^2} r\right), \quad \psi = e^{\pm i k_{az} z} e^{\pm i m \phi}, \quad (3.23)$$

where  $J_m$  is the  $m^{\text{th}}$ -order cylindrical Bessel's function, where the signs (+) and (-) depend on the direction of propagation of the wave (see Chapter 4), and

$$\hat{v}_{vz} = \alpha \frac{C_m(R)}{k_v^2} J_m\left(\sqrt{k_v^2 - k_{az}^2} r\right),$$

$$\hat{v}_{v\phi} = \frac{\alpha}{k_v^2 - k_{az}^2} \left[ r \frac{\partial}{\partial r} - \frac{k_{az}^2}{k_v^2} C_m(R) \right] J_m\left(\sqrt{k_v^2 - k_{az}^2} r\right), \quad (3.24)$$

$$\hat{v}_{vr} = \frac{\alpha}{k_v^2 - k_{az}^2} \left[ \frac{m^2}{r} - \frac{k_{az}^2}{k_v^2} C_m(R) \right] \frac{\partial}{\partial r} J_m\left(\sqrt{k_v^2 - k_{az}^2} r\right),$$

$$\text{with } C_m(R) = R \frac{\partial}{\partial R} \frac{J_m\left(\sqrt{k_v^2 - k_{az}^2} R\right)}{J_m\left(\sqrt{k_v^2 - k_{az}^2} R\right)},$$

$$\text{and } \alpha = \frac{-i}{k_0 \rho_0 c_0} \frac{\gamma \hat{\beta}}{\gamma - 1} [1 - i(\gamma - 1) k_0 \ell_h] \frac{k_v^2 J_m\left(\sqrt{k_a^2 - k_{az}^2} R\right)}{R \frac{\partial}{\partial R} J_m\left(\sqrt{k_v^2 - k_{az}^2} R\right)}.$$

The solution to the equation obtained by substituting these results into equation (2.111) is the complex axial wavenumber  $k_{az}$  (propagation constant) that represents the speed of propagation and attenuation of the waves along the  $\vec{Oz}$  axis.

These problems can often be approximated by introducing the equivalent impedance previously presented. On the other hand, curved surfaces can be represented locally by their associated tangent planes as long as the radius of curvature is significantly greater than the thickness of the visco-thermal boundary layers.

### 3.3. Spherical wave in infinite space: Green's function

#### 3.3.1. Impulse spherical source

Let a sphere of radius  $a$ , centered on  $\vec{r}_0$  and immersed in a fluid, be in radial vibrational motion independent of the point considered on the surface (Figure 3.2)

and generating an acoustic wave at a point  $\vec{r}$  beyond the surface of the sphere. The visco-thermal dissipation is here considered in the wave propagation, whereas the effects of boundary layers at the surface of the sphere are ignored so that the source is characterized by its volume velocity  $Q_0(t)$ , product of the area  $4\pi a^2$  by the vibration velocity ( $Q_0$  being the volume of matter introduced in the exterior medium by unit of time).

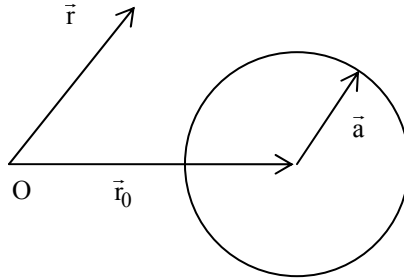

**Figure 3.2.** Spherical source of radius  $a$  and centered on  $\vec{r}_0$

When considering the velocity potential  $\phi$  defined in first approximation by  $\vec{v}_a = \text{grad } \phi$  (1.63) ( $\vec{v}_a$  being the acoustic particle velocity) leading to  $p = -\rho_0 \partial\phi / \partial t$  (1.67), and the acoustic propagation operator (2.76)

$$\overleftrightarrow{\mathcal{L}}_h = \left( 1 + \ell_{vh} \frac{1}{c_0} \frac{\partial}{\partial t} \right) \Delta - \frac{1}{c_0^2} \frac{\partial^2}{\partial t^2}, \quad (3.25)$$

the considered problem can be written as

$$\left\{ \begin{array}{l} \overleftrightarrow{\mathcal{L}}_h \phi(\vec{r}, t) = 0, \quad \forall \vec{r} \text{ such that } |\vec{r} - \vec{r}_0| > a, \\ \frac{\partial \phi(\vec{r}, t)}{\partial a} = \frac{Q_0(t)}{4\pi a^2}, \quad \text{for } \vec{r} = \vec{r}_0 + \vec{a}, \\ \text{Sommerfeld's conditions at infinity (no back-propagating wave),} \\ \text{Null initial conditions.} \end{array} \right. \quad (3.26)$$

A spherical source, the radius of which is small compared to the shortest wavelengths considered, is called a quasi-point source and sometimes a point source and is qualified as a monopolar source or monopole. It is this type of source that is considered in this section, assuming constant total volume velocity  $Q_0$ .



The considered problem can be written as

$$\left\{ \begin{array}{l} \overleftrightarrow{\varepsilon}_{\text{vh}} \varphi(\vec{r}, t) = 0, \quad \forall \vec{r} \neq \vec{r}_0, \\ \frac{\partial \varphi(\vec{r}, t)}{\partial (|\vec{r} - \vec{r}_0|)} = \lim_{a \rightarrow 0} \frac{Q_0(t)}{4\pi a^2}, \quad \text{for } |\vec{r} - \vec{r}_0| = a \rightarrow 0, \\ \text{Sommerfeld's conditions at infinity (no back-propagating wave),} \\ \text{Null initial conditions.} \end{array} \right. \quad (3.27)$$

Rather than writing the effect of the source as a boundary condition (at  $\vec{r} = \vec{r}_0$ ), one can introduce a volume velocity term  $q$  (see equation (1.61)) in the non-homogeneous term of the equation of propagation, that is a volume of matter introduced in the medium by unit of volume and time. The function  $q$ , describing the effect of the point source at  $\vec{r}_0$ , must satisfy the following equation:

$$\iiint_D q d\vec{r} = Q_0 = \iiint_D Q_0 \delta(\vec{r} - \vec{r}_0) d\vec{r}, \quad (3.28)$$

where the domain ( $D$ ) represents the infinite space and  $\delta$  the Dirac function.

This function  $q$  can then be written as

$$q = Q_0 \delta(\vec{r} - \vec{r}_0), \quad (3.29)$$

and the considered problem is fully described by

$$\left\{ \begin{array}{l} \overleftrightarrow{\varepsilon}_{\text{vh}} = \varphi(\vec{r}, t) = Q_0(t) \delta(\vec{r} - \vec{r}_0), \\ \text{Sommerfeld's conditions at infinity (no back-propagating wave),} \\ \text{Null initial conditions.} \end{array} \right. \quad (3.30)$$

Clearly, the point source can be introduced in either the boundary conditions or the non-homogeneous term of the equation of propagation since it is not distributed within the considered domain.

In the particular case where the source is not only punctual, but generates an impulse of unit volume velocity at the time  $t_0$  characterized by  $Q_0(t) = \delta(t - t_0)$  (“click” sound, very brief), defining a function  $G = -\varphi$ , called conventionally the Green’s function (or elementary solution), the elementary problem becomes

$$\left[ \left( 1 + \ell_{\text{vh}} \frac{1}{c_0} \frac{\partial}{\partial t} \right) \Delta - \frac{1}{c_0^2} \frac{\partial^2}{\partial t^2} \right] G(\vec{r}, t; \vec{r}_0, t_0) = -\delta(t - t_0) \delta(\vec{r} - \vec{r}_0). \quad (3.31)$$

Equation (3.31) is valid at any point of the domain considered and at any time  $t$  where Sommerfeld's condition and null initial conditions can be applied (null field until  $t = t_0$ ).

### 3.3.2. Green's function in three-dimensional space

The four-dimensional Fourier transform of equation (3.31) is

$$\left[ \left( 1 + i \frac{\omega}{c_0} \ell_{\text{vh}} \right) \chi^2 - \frac{\omega^2}{c_0^2} \right] \tilde{G}(\vec{\chi}, \omega) = 1, \quad (3.32)$$

where  $\tilde{G}(\vec{\chi}, \omega)$  is the Fourier transform of the function  $G$  defined by

$$G(\vec{r}, t; \vec{r}_0, t_0) = \frac{1}{(2\pi)^3} \iiint d^3\vec{\chi} e^{-i\vec{\chi} \cdot (\vec{r} - \vec{r}_0)} \frac{1}{2\pi} \int_{-\infty}^{\infty} d\omega \tilde{G}(\vec{\chi}, \omega) e^{i\omega(t-t_0)}. \quad (3.33)$$

The integration with respect to the variable  $\omega$

$$\frac{c_0^2}{2\pi} \int_{-\infty}^{\infty} \frac{e^{i\omega(t-t_0)} d\omega}{\omega^2 - \left( 1 + i \frac{\omega}{c_0} \ell_{\text{vh}} \right) c_0^2 \chi^2}, \quad (3.34)$$

can quite simply be estimated by the method of residues in the complex angular frequency domain since the poles are not on the real axis, but in the superior half-plane, closing the contour of integration with the superior half-plane for  $t > t_0$  and by the inferior half-plane for  $t < t_0$  (Figure 3.3).

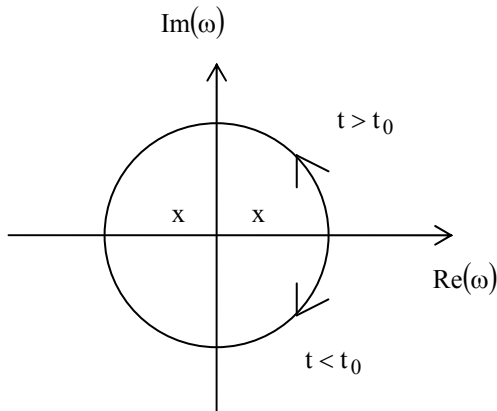

**Figure 3.3.** Contour integration and position of the poles ( $x$ ) in the complex plane of  $\omega$

Note that if dissipation were ignored, the poles would be on the real angular frequency axis, giving four different paths of integration when only one corresponds with a real physical situation (where the poles are bypassed by negative imaginary values, because of their position in the complex plane when dissipation is considered). Also, any additional dissipation considered will result in a translation of the poles toward positive imaginary parts.

The poles are given by

$$\omega = \pm \sqrt{c_0^2 \chi^2 - \left( \frac{c_0 \ell_{vh}}{2} \chi^2 \right)^2} + i \frac{c_0 \ell_{vh}}{2} \chi^2,$$

or, in first approximation, by

$$\omega \approx \pm c_0 \chi + i \frac{c_0 \ell_{vh}}{2} \chi^2, \quad (3.35)$$

and the integral (3.34) is

$$c_0^2 U(t-t_0) \exp \left[ -\frac{1}{2} c_0 \ell_{vh} \chi^2 (t-t_0) \right] \frac{\sin [c_0 \chi (t-t_0)]}{c_0 \chi}, \quad (3.36)$$

where  $U(t-t_0)$ , function of Heaviside, accounts for the causality.

The integration of equation (3.33) with respect to the variable  $\vec{\chi}$ , considering equation (3.36), is carried out by choosing the  $\vec{Oz}$  axis (from the coordinate system for  $\vec{\chi}$ ) collinear to the vector  $\vec{R} = \vec{r} - \vec{r}_0$ , so that, in spherical coordinates,

$$\begin{aligned} \vec{\chi} \cdot \vec{R} &= \chi R \cos \theta \\ d^3 \vec{\chi} &= \chi^2 d\chi \sin \theta d\theta d\varphi, \end{aligned}$$

and since the integrand does not depend on the angle  $\varphi$  and denoting  $\tau = t - t_0$  (not to understand as a temperature variation), the Green's function is in the form

$$\begin{aligned} G(\vec{R}, \tau) &= \frac{-ic_0^2 U(\tau)}{(2\pi)^3} (2\pi) \int_0^\pi \sin \theta d\theta \\ &\int_0^\infty \chi^2 d\chi e^{-i\chi R \cos \theta} e^{-c_0 \ell_{vh} \chi^2 \tau / 2} \frac{[e^{ic_0 \chi \tau} - e^{-ic_0 \chi \tau}]}{2c_0 \chi}. \end{aligned} \quad (3.37a)$$

The integration with respect to  $\theta$  is immediate; it leads to an integrand that is the sum of four exponential functions, reduced to two by replacing the inferior boundary (0) by  $(-\infty)$

$$G(\vec{R}, \tau) = \frac{-c_0 U(\tau)}{2(2\pi)^2 R} \int_{-\infty}^{+\infty} e^{-c_0 \ell_{vh} \chi^2 \tau / 2} \left[ e^{i\chi(R+c_0\tau)} - e^{i\chi(R-c_0\tau)} \right] d\chi. \quad (3.37b)$$

These integrals happen to be the Fourier transforms of non-centered Gauss functions, thus

$$G(\vec{R}, \tau) = \frac{c_0 U(\tau)}{4\pi R} \frac{1}{\sqrt{2\pi \ell_{vh} c_0 \tau}} \left[ \exp\left(-\frac{(R-c_0\tau)^2}{2\ell_{vh} c_0 \tau}\right) - \exp\left(-\frac{(R+c_0\tau)^2}{2\ell_{vh} c_0 \tau}\right) \right]. \quad (3.38)$$

At the limit of non-dissipative fluid ( $\ell_{vh} \rightarrow 0$ ), equation (3.37) becomes

$$G(\vec{R}, \tau) = \frac{c_0 U(\tau)}{2(2\pi)^2 R} \int_{-\infty}^{+\infty} \left[ e^{i\chi(R-c_0\tau)} - e^{i\chi(R+c_0\tau)} \right] d\chi. \quad (3.39)$$

which, changing the variable to  $x = c_0 \chi$ , becomes

$$G(\vec{R}, \tau) = \frac{U(\tau)}{4\pi R} \left[ \delta\left(\frac{R}{c_0} - \tau\right) - \delta\left(\frac{R}{c_0} + \tau\right) \right] = \frac{1}{4\pi R} \delta\left(\frac{R}{c_0} - \tau\right), \quad (3.40)$$

$$\text{since } U(\tau) \delta\left(\frac{R}{c_0} + \tau\right) = 0.$$

The impulse spherical wave generated at  $(\vec{r}_0, t_0)$  is distributed over the surface of a sphere of radius  $\vec{R} = |\vec{r} - \vec{r}_0|$  at the time  $t = t_0 + R/c_0$ , attenuated with the distance  $R$  traveled.

In the frequency domain, the Green's function (still denoted  $G$ ) satisfies the equation

$$\left[ (1 + ik_0 \ell_{vh}) \Delta + k_0^2 \right] G(\vec{r} - \vec{r}_0, \omega) = -\delta(\vec{r} - \vec{r}_0), \text{ where } k_0 = \omega/c_0, \quad (3.41)$$

and is given by

$$G(\vec{R}, \omega) = \frac{1}{1 + ik_0 \ell_{vh}} \frac{1}{(2\pi)^3} \iiint d^3 \vec{\chi} \frac{e^{-i\vec{\chi} \cdot \vec{R}}}{\chi^2 - k_0^2 / (1 + ik_0 \ell_{vh})}. \quad (3.42)$$

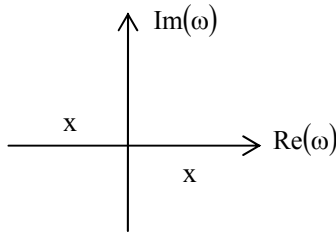

**Figure 3.4.** Poles of the integrand in equation (3.42) in the complex wavenumber ( $\chi$ ) plane

Where the poles of the integrand being located as in Figure 3.4, the integration by the method of residues gives

$$\begin{aligned}
 G(R, \omega) &= \frac{1}{1 + ik_0 \ell_{vh}} \frac{1}{4\pi R} e^{-i \frac{k_0}{\sqrt{1 + ik_0 \ell_{vh}}} R} \\
 &\approx \frac{1}{4\pi R} e^{-ik_0 \left(1 - \frac{i}{2} k_0 \ell_{vh}\right) R} \approx \frac{e^{-ikR}}{4\pi R},
 \end{aligned}
 \tag{3.43}$$

and, for non-dissipative fluid ( $\ell_{vh} \rightarrow 0$ ),

$$G(R, \omega) = \frac{e^{-ik_0 R}}{4\pi R} = \frac{-ik_0}{4\pi} h_0^-(k_0 R),
 \tag{3.44}$$

where  $h_0^-$  is the 0<sup>th</sup>-order spherical Hankel's function of the first kind.

Note that equation (3.44) can be obtained directly from equation (3.40) by noting that

$$\begin{aligned}
 \frac{1}{4\pi R} \delta\left(\frac{R}{c_0} - \tau\right) &= \frac{1}{2\pi} \int_{-\infty}^{+\infty} \frac{1}{4\pi R} e^{-i\omega\left(\frac{R}{c_0} - \tau\right)} d\omega, \\
 &= \frac{1}{2\pi} \int_{-\infty}^{+\infty} \frac{e^{-ik_0 R}}{4\pi R} e^{i\omega\tau} d\omega.
 \end{aligned}
 \tag{3.45}$$

### 3.4. Digression on two- and one-dimensional Green's functions in non-dissipative fluids

#### 3.4.1. Two-dimensional Green's function

##### 3.4.1.1. Time domain

The two-dimensional Green's function represents the displacement field of a membrane (for example) under the action of an impulse-point source. Intuitively, it also represents the velocity potential generated in a three-dimensional space by an infinite cylinder of radius close to zero, the surface of which is in impulse radial motion. This implies that a line source can be considered as a superposition of monopoles along an axis (chosen here as the  $z_0$ -axis) and that the corresponding Green's function can be found in the form of an integral with respect to the variable  $z_0$ . This derivation is detailed here using a cylindrical coordinate system for the variables  $\bar{r}(\bar{w}, z)$  and  $\bar{r}_0(\bar{w}_0, z_0)$ .

Since the D'Alembertian operator  $\nabla^2$  (here non-dissipative) is independent of  $z_0$ , the integral of the three-dimensional Green's function (in the time domain) over  $z_0$  can be written as

$$\begin{aligned} \left[ \Delta_{\bar{w}} + \frac{\partial^2}{\partial z^2} - \frac{1}{c_0^2} \frac{\partial^2}{\partial t^2} \right] \int_{-\infty}^{+\infty} \frac{\delta\left(\frac{1}{c_0} \sqrt{\rho^2 + (z-z_0)^2} - \tau\right)}{4\pi\sqrt{\rho^2 + (z-z_0)^2}} dz_0 \\ = - \int_{-\infty}^{+\infty} \delta(\bar{w} - \bar{w}_0) \delta(z - z_0) \delta(t - t_0) dz_0, \end{aligned} \quad (3.46)$$

with  $\rho = |\bar{w} - \bar{w}_0|$  and  $\tau = t - t_0$ .

By using a new variable defined by  $R^2 = (z - z_0)^2 + \rho^2$ , so that  $\frac{dz_0}{R} = \frac{dR}{z_0 - z}$

or

$$\frac{dz_0}{R} = \begin{cases} \frac{dR}{\sqrt{R^2 - \rho^2}}, & \text{if } z_0 \geq z, \\ -\frac{dR}{\sqrt{R^2 - \rho^2}}, & \text{if } z_0 \leq z, \end{cases}$$

with  $R \rightarrow 0$  when  $z_0 \rightarrow \pm\infty$ , and  $R = \rho$  when  $z_0 = z$ , leads to

$$\begin{aligned} & \int_{-\infty}^{+\infty} \frac{\delta\left(\frac{1}{c_0} \sqrt{\rho^2 + (z-z_0)^2} - \tau\right)}{4\pi\sqrt{\rho^2 + (z-z_0)^2}} dz_0 \\ &= \frac{1}{4\pi} \left[ \int_{-\infty}^{\rho} \frac{\delta\left(\frac{R}{c_0} - \tau\right)}{-\sqrt{R^2 - \rho^2}} dR + \int_{\rho}^{+\infty} \frac{\delta\left(\frac{R}{c_0} - \tau\right)}{\sqrt{R^2 - \rho^2}} dR \right], \tag{3.47} \\ &= \frac{1}{2\pi} \int_{\rho}^{+\infty} \frac{\delta\left(\frac{R}{c_0} - \tau\right)}{\sqrt{R^2 - \rho^2}} dR. \end{aligned}$$

Equation (3.47) is independent of the variable  $z$ . Consequently, the operator  $\partial^2 / \partial z^2$  of equation (3.46), when applied to the function given by equation (3.47), vanishes and equation (3.46) becomes

$$\left( \Delta_{\bar{w}} - \frac{1}{c_0^2} \frac{\partial^2}{\partial t^2} \right) G(\rho, \tau) = -\delta(\bar{w} - \bar{w}_0) \delta(t - t_0), \tag{3.48}$$

showing that the function  $G(\rho, \tau) = \frac{1}{2\pi} \int_{\rho}^{\infty} dR \frac{\delta\left(\frac{R}{c_0} - \tau\right)}{\sqrt{R^2 - \rho^2}}$  is the two-dimensional

Green's function sought, which can also be written, denoting  $X = R / c_0$ , as

$$\begin{aligned} G(\rho, \tau) &= \frac{1}{2\pi} \int_{\rho/c_0}^{\infty} \frac{\delta(X - \tau)}{\sqrt{X^2 - \rho^2 / c_0^2}} dX, \\ \text{or } G(\rho, \tau) &= \frac{U(\tau - \rho / c_0)}{2\pi\sqrt{\tau^2 - \rho^2 / c_0^2}}, \tag{3.49} \end{aligned}$$

where  $U$  is the unit Heaviside function introducing the causality.

The two-dimensional Green's function in the time domain reveals a fundamental characteristic of elementary propagation in two-dimensional spaces; after a certain period of time  $\tau = t - t_0$ , the effect of an impulse generated by a point source at the

time  $t_0$  induces a pulse train signal over the entire domain  $\rho < c_0 \tau$  (centered on the source at  $\bar{w}_0$ ).

Note: the proposed approach is valid in both dissipative and non-dissipative fluids.

### 3.4.1.2. Frequency domain

Similarly, integrating the three-dimensional Green's function in the frequency domain over the variable  $z_0$  (for example) gives the corresponding two-dimensional Green's function (independent of the variable  $z$ ),

$$G(\rho, \omega) = \int_{-\infty}^{\infty} \frac{e^{-ik\sqrt{\rho^2 + (z-z_0)^2}}}{4\pi\sqrt{\rho^2 + (z-z_0)^2}} dz_0 = -\frac{i}{4} H_0^-(k|\bar{w} - \bar{w}_0|), \quad (3.50)$$

where  $H_0^-$  is the 0<sup>th</sup>-order cylindrical Hankel's function of the first kind (one of its definition is given by equation (3.50)).

This result can also be obtained as follows: since the three-dimensional Green's function (section 3.3.2) can be considered as a superposition of all solutions  $e^{-i\bar{\chi} \cdot (\bar{r} - \bar{r}_0)}$  to the propagation operator in the frequency domain in an infinite domain (Helmholtz operator) that constitute, when normalized to the unit, a basis of the infinite space,

$$\iiint \frac{1}{(2\pi)^3} \exp[-i(\bar{\chi}' - \bar{\chi}) \cdot \bar{R}] d\bar{R}^3 = \delta(\bar{\chi}' - \bar{\chi}).$$

The two-dimensional Green's function can be expanded, in polar coordinates in the basis of the eigenfunctions of Laplace operator, as

$$\psi_m(\chi_m, \bar{w}) = \frac{1}{\sqrt{2\pi}} e^{-im\varphi} \sqrt{\frac{\chi_m}{2\pi}} J_m(\chi_m w), \quad (3.51)$$

$$\text{where } \int_0^\infty w dw \int_0^{2\pi} \psi_m(\chi_m, \bar{w}) \psi_{m'}^*(\chi_m, \bar{w}) d\varphi = \delta(\chi_m, \chi_{m'}),$$

and where

$$\begin{aligned} \Delta_{\bar{w}} \psi_m(\chi_m, \bar{w}) &= \left[ \frac{1}{w} \frac{\partial}{\partial w} \left( w \frac{\partial}{\partial w} \right) + \frac{1}{w^2} \frac{\partial^2}{\partial \varphi^2} \right] \psi_m(\chi_m, \bar{w}), \\ &= -\chi_m^2 \psi_m(\chi_m, \bar{w}). \end{aligned} \quad (3.52)$$

The basis of functions  $\psi_m$  is restricted to the set of functions that are finite at the origin (see Chapter 5). Thus, by introducing a small, additional, dissipative



factor in Green's equation  $(\Delta_{\bar{w}} + k^2)G = -\delta(\bar{w} - \bar{w}_0)$ , and following the procedure presented in section 3.3.2, the two-dimensional Green's function can be written as

$$G(\bar{w}, \bar{w}_0; \omega) = \frac{1}{4\pi^2} \sum_{m=-\infty}^{\infty} e^{-im(\varphi-\varphi_0)} \int_{-\infty}^{+\infty} \frac{J_m(\chi_m w_0) J_m(\chi_m w)}{(1+i\varepsilon)\chi_m^2 - k_0^2} \chi_m d\chi_m. \quad (3.53)$$

The location of the poles in the  $\chi_m$ -plane is given in Figure 3.5(a). By limiting the analysis to non-dissipative fluids ( $\varepsilon = 0$ ), the poles on the real axis must be excluded from the integration contour of equation (3.53) (Figure 3.5(b)).

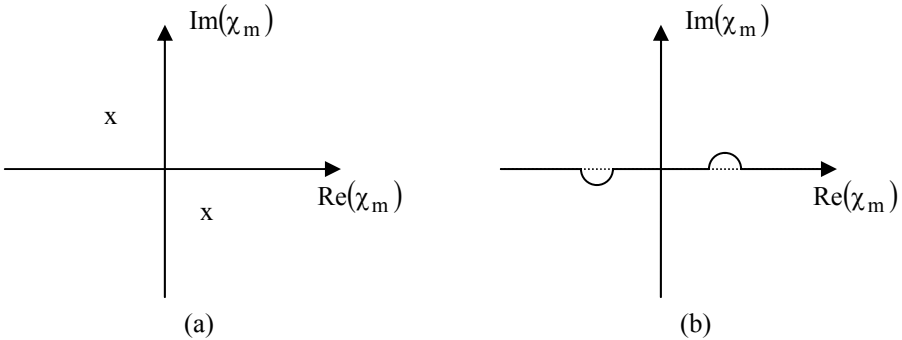

**Figure 3.5.** (a) Location of the poles of equation (3.53) in the complex wavenumber plane, (b) Integration path on the real wavenumbers axis for non-dissipative fluids

By following the contour given in Figure 3.5, equation (3.53) constitutes another expression of the function  $\left(-\frac{i}{4}H_0^-\right)$  and is therefore the Green's function  $G(\rho, \omega)$  (equation (3.50)).

### 3.4.2. One-dimensional Green's function

#### 3.4.2.1. Time domain

A uniform plane source in a three-dimensional space extending in a plane perpendicular to the considered axis ( $x$ -axis here) and intercepting the axis at  $x_0$  is associated to a point source in a one-dimensional domain. The one-dimensional Green's function can be obtained using a similar approach as in section 3.4.1.1 by integrating the two-dimensional Green's function (equation (3.49)) over the variable  $y_0$ . When denoting  $\zeta = x - x_0$ ,  $\eta = y - y_0$  and  $v = \sqrt{c_0^2 \tau^2 - \zeta^2}$ , this Green's function can be written as

$$G(\zeta, \tau) = \begin{cases} \frac{c_0}{2\pi} \int_{-v}^{+v} \frac{d\eta}{\sqrt{v^2 - \eta^2}} = \frac{c}{2\pi} \left[ \text{Arcsin} \frac{\eta}{v} \right]_{-v}^{+v}, & \text{if } |\zeta| < c_0 \tau, \\ 0, & \text{if } |\zeta| > c_0 \tau. \end{cases}$$

$$\text{thus } G(\zeta, \tau) = \frac{c_0}{2} \left[ 1 - U \left( \frac{|\zeta|}{c_0} - \tau \right) \right] = \frac{c_0}{2} U \left( \tau - \frac{|\zeta|}{c_0} \right). \quad (3.54)$$

This function is independent of the variable  $y$  and consequently is the solution to

$$\left[ \frac{\partial^2}{\partial x^2} - \frac{1}{c_0^2} \frac{\partial^2}{\partial t^2} \right] G = -\delta(x - x_0) \delta(t - t_0).$$

Note that the effect of impulse emitted at  $t_0$  and  $x_0$  is not localized at the point  $x$  defined by  $x - x_0 = \pm c_0(t - t_0)$  but within an extended domain  $2c_0(t - t_0)$  centered on  $x_0$ , as is the case for an elastic string, for example.

#### 3.4.2.2. Frequency domain

The Fourier transform of equation (3.54) gives the one-dimensional Green's function in the frequency domain as

$$G(x - x_0, \omega) = \frac{e^{-ik_0|x-x_0|}}{2ik_0}. \quad (3.55)$$

This is verified by finding the solution to

$$\left( \frac{\partial^2}{\partial x^2} + k_0^2 \right) G = -\delta(x - x_0) \quad (3.56)$$

as an expansion in the basis of orthonormal one-dimensional plane waves

$$\frac{1}{\sqrt{2\pi}} e^{-i\chi\zeta} \quad (\zeta = x - x_0), \text{ eigenfunctions of the operator } d^2/dx^2,$$

$$\frac{d^2}{dx^2} e^{-i\chi\zeta} = -\chi^2 e^{-i\chi\zeta}, \quad (3.57)$$

leading to

$$G(\zeta, \omega) = \frac{1}{2\pi} \int_{-\infty}^{\infty} d\chi \hat{G}(\chi, \omega) e^{-i\chi\zeta}. \quad (3.58)$$

The substitution of equation (3.58) into equation (3.56) gives

$$\tilde{G} = \frac{1}{\chi^2 - k_0^2}. \tag{3.59}$$

Assuming once more that considering dissipation is equivalent to replacing  $k_0$  by a complex wavenumber  $k_0(1 - i\varepsilon)$ , the locations of the poles of the integrand (3.59) are given in Figure 3.6(a). Therefore, the integral (3.58) can be calculated by using the method of residues along the contour shown in Figure 3.6(b). Finally,

$$G = -\frac{1}{2\pi} 2i\pi \frac{e^{-ik_0\zeta}}{2k_0} = \frac{e^{-ik_0\zeta}}{2ik_0} \text{ for } \zeta > 0,$$

$$G = -\frac{1}{2\pi} 2i\pi \frac{e^{ik_0\zeta}}{2k_0} = \frac{e^{ik_0\zeta}}{2ik_0} \text{ for } \zeta < 0,$$

$$\text{thus } G(x, x_0; \omega) = \frac{e^{-ik_0|x-x_0|}}{2ik_0}. \tag{3.60}$$

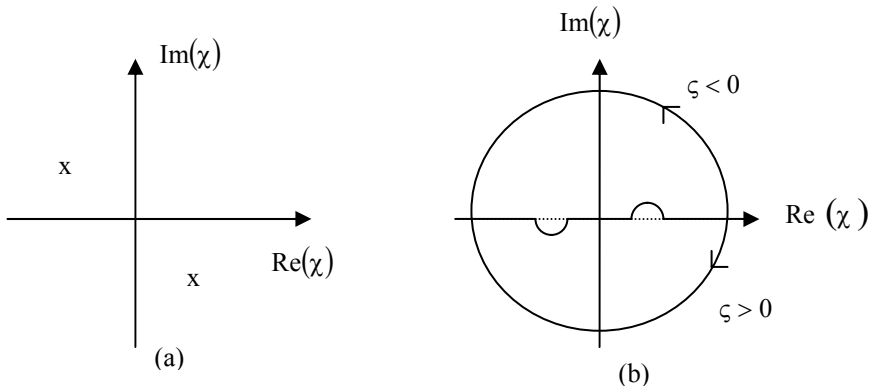

**Figure 3.6.** (a) Location of the poles of equation (3.59) in the complex wavenumber plane; (b) Integration path on the real wavenumber axis for non-dissipative fluids

Note: this function illustrates the fact that the point source radiates an acoustic wave on both sides, one propagating toward the  $x < x_0$  and the other toward the  $x > x_0$ . This type of solution, a one-dimensional plane wave, is discussed in detail at the beginning of Chapter 4.

### 3.5. Acoustic field in “small cavities” in harmonic regime

The objective of this section is to express the pressure field generated (or perturbed) in a “small cavity” by vibrating walls and/or by the presence of a hole (with a fluid displacement  $\xi$ ) and by the supply of time-dependent uniform heat  $h$ , expressed per unit of time and mass (obtained by transformation of light or electric energy into heat, for example). The term “small cavity” describes a cavity the dimensions of which are significantly smaller than the wavelength  $\lambda_0$  but remain much greater than the thickness  $\delta_{v,h}$  of the boundary layers

$$\lambda_0 \gg \sqrt[3]{V}, \quad \delta_{v,h} \ll \sqrt[3]{V},$$

where  $V$  denotes the volume of the cavity. This type of cavity is widely used, and particularly in electro-acoustic transducers.

There are four variables in the problem,  $(p, \vec{v}, \rho', \tau)$ , and the equations are Navier-Stokes, mass conservation, heat conduction, and an equation stating that  $\rho'$ , for example, is a total exact differential (see section 1.2.6). Given the particular property of the problem, it is necessary to choose the most appropriate form of the aforementioned equations. The boundary conditions (no temperature gradient, vanishing tangential particle velocity and normal particle velocity related to the displacement  $\xi$  and the wall impedance  $Z$  (equation (1.69)) are introduced one after the other when needed.

#### *Navier-Stokes equation*

Since the dimensions of the cavity are significantly smaller than the wavelength considered and that the pressure field does not present spatial variations at the vicinity of the wall, this pressure field can be assumed uniformly distributed in the cavity (only time dependent, and hypothetically harmonic). Therefore,  $\text{grad } p = \vec{0}$ , the particle velocity is null (quasi-null) at any point in the cavity (which does not necessarily mean that the surface velocity is negligible) and the viscosity effects do not intervene. These are the conclusions drawn from the analysis of the Navier-Stokes equation, the quantitative description of which is given in section 6.3.2.2.

#### *Mass conservation law*

The mass conservation law can be written in a linearized form (1.27) as

$$\iiint_V \left[ \frac{\partial \rho'}{\partial t} + \text{div}(\rho_0 \vec{v}) \right] dV = 0,$$

$$\text{thus } \iiint_V \frac{\partial \rho'}{\partial t} dV + \rho_0 \iint_S \vec{v} \cdot d\vec{S} = 0. \quad (3.61)$$

According to the accepted assumptions that some walls of the cavity are vibrating with a displacement  $\xi$  and others are simply characterized by their impedance  $Z$ , this equation can also be written, in the frequency domain, as

$$\iiint_V i\omega\rho' dV + i\omega\rho_0 \iint_S \bar{\xi} d\bar{S} + \rho_0 \iint_S \frac{P}{Z} dS = 0. \quad (3.62)$$

Since the pressure field is uniform in the cavity,

$$\iint_S \frac{P}{Z} dS = p \iint_S \frac{1}{Z} dS = pS/\bar{Z}, \quad (3.63)$$

where  $1/\bar{Z}$  denotes the average value of the wall admittance, equation (3.62) becomes

$$\frac{1}{\rho_0} \iiint_V \rho' dV + \delta V + \frac{pS}{i\omega\bar{Z}} = 0, \quad (3.64)$$

where  $\delta V = \iint \bar{\xi} d\bar{S}$  denotes the variation of the cavity volume due to the vibrations of the wall.

### ***Expression of the bivariance of the media***

The linearized form of equation (1.23) is

$$\rho' = \rho_0 \chi_T (p - \hat{\beta} \tau).$$

Substituting the above equation into equation (3.64) gives

$$p \left[ 1 + \frac{S}{i\omega\bar{Z}\chi_T V} \right] - \frac{\hat{\beta}}{V} \iiint_V \tau dV = -\frac{\delta V}{\chi_T V}. \quad (3.65)$$

The triple integral of the temperature variation (both acoustic and entropic) is yet to be estimated.

### ***Equation of heat conduction***

The equation of heat conduction can be derived in the frequency domain from its form (2.66), as

$$\left( \frac{i\omega}{c_0} - \ell_h \Delta \right) \tau = \frac{\gamma-1}{\hat{\beta}\gamma} \frac{i\omega}{c_0} p + \frac{h}{c_0 C_p}, \quad (3.66)$$

$$\text{or } \tau = \frac{c_0 \ell_h}{i\omega} \Delta \tau + \frac{\gamma-1}{\hat{\beta}\gamma} p + \frac{h}{i\omega C_p}. \quad (3.67)$$

The combination of equation (3.67) and the uniformly distributed pressure field  $p$  and source function  $h$  (by hypothesis) yields

$$\iiint_V \tau dV = \frac{c_0 \ell_h}{i\omega} \iint_S \text{grad} \tau \cdot d\vec{S} + \frac{\gamma-1}{\hat{\beta}\gamma} V p + \frac{V h}{i\omega C_p}. \quad (3.68)$$

Also, the solution to equation (3.66) satisfying  $\tau = 0$  at the boundaries can be written (the time factor  $e^{i\omega t}$  being suppressed) as

$$\tau = \left[ \frac{\gamma-1}{\hat{\beta}\gamma} p + \frac{h}{i\omega C_p} \right] \left[ 1 - e^{-ik_h u} \right], \quad (3.69)$$

where  $u$  represents the position in the cavity projected onto the outward normal to the wall ( $u = 0$  on the wall). This form of solution is acceptable only if:

i) the thickness of the thermal layers is significantly smaller than the dimensions of the cavity, meaning that the function  $e^{-ik_h u}$  decreases very fast as  $u$  increases;

ii) the condition

$$k_h = \sqrt{\frac{-i\omega}{c_0 \ell_h}} = \frac{-1+i}{\sqrt{2}} \sqrt{\frac{\omega}{c_0 \ell_h}} \quad (3.70)$$

is imposed so that the function represents a wave of thermal diffusion that penetrates the cavity from the walls.

If all these conditions are assumed, equation (3.69) taken at the boundary  $u = 0$  leads to

$$\begin{aligned} \frac{\partial}{\partial u} \tau &= \left( \frac{\gamma-1}{\hat{\beta}\gamma} p + \frac{h}{i\omega C_p} \right) \left( -\frac{1+i}{\sqrt{2}} \sqrt{\frac{\omega}{c_0 \ell_h}} \right), \\ \text{and } \iint_S \text{grad} \tau \cdot d\vec{S} &= \iint_S \frac{\partial \tau}{\partial u} dS = -\frac{1+i}{\sqrt{2}} \sqrt{\frac{\omega}{c_0 \ell_h}} S \left( \frac{\gamma-1}{\hat{\beta}\gamma} p + \frac{h}{i\omega C_p} \right), \end{aligned} \quad (3.71)$$

and finally to

$$\iiint_V \tau dV = \left[ V - \frac{1-i}{\sqrt{2}} S \sqrt{\frac{c_0 \ell_h}{\omega}} \right] \left[ \frac{\gamma-1}{\hat{\beta}\gamma} p + \frac{h}{i\omega C_p} \right]. \quad (3.72)$$

The substitution of equation (3.72) into equation (3.65) gives the following expression of the pressure amplitude in the cavity:

$$p = \frac{-\frac{\gamma \delta V}{\chi_T V} + \left(1 - \frac{1-i}{\sqrt{2}} \frac{S}{V} \sqrt{\frac{c_0 \ell_h}{\omega}}\right) \frac{\gamma \hat{\beta}}{i\omega C_p} h}{1 + \frac{\gamma S/V}{i\omega \bar{Z} \chi_T} + \frac{1-i}{\sqrt{2}} (\gamma-1) \frac{S}{V} \sqrt{\frac{c_0 \ell_h}{\omega}}}. \quad (3.73)$$

The numerator introduces two “source” terms. The first one,  $\frac{-\gamma \delta V}{\chi_T V}$ , source term (due to the forced vibrations of the wall) or passive term (vibration of the wall induced by the pressure) is proportional to the variation of volume  $\delta V$  and contributes to the pressure variation resulting from the adiabatic process represented by the coefficient of adiabatic compressibility  $\chi_T/\gamma$ . The second term,  $\frac{\gamma \hat{\beta}}{i\omega C_p}$ , contributes to the pressure variation associated with the heat supply at constant volume; this “transformation” is moderated by the thermal conduction of the wall absorbing part of the thermal energy generated by the source ( $(S/V)\sqrt{\ell_h}$  factor).

The denominator accounts for the dissipative effect related to the average admittance  $1/\bar{Z}$  of the wall and to the thermal conduction.

Note that all the dissipative factors are proportional to the ratio of the surface to the volume of the cavity ( $S/V$ ); the sphere is therefore the least absorbing cavity at constant volume.

Note: the particular case of the spherical cavity.

If the cavity is spherical, the average value of the temperature variation  $\tau$  is given by

$$\langle \tau \rangle = \frac{1}{V} \iiint_V \tau dV$$

and can be explicitly derived from the solution to equation (3.66) in spherical coordinates by assuming spherical symmetry and not necessarily assuming that the radius of the sphere is greater than the thickness of the thermal boundary layers.

This solution for  $\tau$ , sum of the particular solution

$$\frac{\gamma-1}{\hat{\beta}\gamma} p + \frac{h}{i\omega C_p}$$

and the general solution to the associated homogeneous equation

$$A \frac{e^{ik_h r}}{r} + B \frac{e^{-ik_h r}}{r}$$

that remains finite at the origin ( $B = -A$ ) and vanishes for  $r = R$  ( $R$  being the radius of the sphere) can be written as

$$\tau = \left( \frac{\gamma - 1}{\hat{\beta}\gamma} p + \frac{h}{i\omega C_p} \right) \left( 1 - \frac{R \sin k_h r}{r \sin k_h R} \right). \quad (3.74)$$

Thus

$$\langle \tau \rangle = \left( \frac{\gamma - 1}{\hat{\beta}\gamma} p + \frac{h}{i\omega C_p} \right) (1 - \Theta), \quad (3.75)$$

with  $\Theta = \frac{3}{k_h^2 R^2} - \frac{3 \cot g(k_h R)}{k_h R}$ , where the wavenumber  $k_h$  is given by equation (3.70).

Consequently, the equation

$$\langle \rho' \rangle = \frac{\gamma}{c_0^2} (p - \hat{\beta} \langle \tau \rangle)$$

becomes

$$\langle \rho' \rangle = \frac{p}{c^2} - \rho_s, \quad (3.76)$$

$$\text{with } \rho_s = \frac{\gamma \hat{\beta}}{c_0^2} (1 - \Theta) \frac{h}{i\omega C_p}$$

$$\text{and } \frac{1}{c^2} = \frac{1}{c_0^2} [1 + (\gamma - 1)\Theta].$$

The last relationship translates a phase difference between  $p$  and  $\langle \rho' \rangle$ , represented by the complex coefficient of compressibility interpreted as a thermal relaxation phenomenon.

Consequently, equation (3.61), written as a function of the flow  $U$  at the wall in the form

$$i\omega \langle \rho' \rangle V = -\rho_0 U$$



is written from equation (3.76) of  $\langle \rho' \rangle$  as

$$p = i \frac{\rho_0 c^2}{\omega V} U + c^2 \rho_s = \frac{-\frac{\gamma \delta V}{\chi_T V} + (1 - \Theta) \frac{\gamma \hat{\beta} h}{i \omega C_p}}{1 + (\gamma - 1) \Theta + \frac{\gamma S/V}{i \omega \bar{Z} \chi_T}} p, \tag{3.77}$$

where  $i \frac{\rho_0 c_0^2}{\omega V} U = -\frac{\gamma \delta V}{\chi_T V} - \frac{\gamma S/V}{i \omega \bar{Z} \chi_T} p$ .

This equation is, at the first order of the asymptotic expansion of the function of argument  $k_h R$ , identical to equation (3.73).

### 3.6. Harmonic motion of a fluid layer between a vibrating membrane and a rigid plate, application to the capillary slit

A layer of dissipative and compressible fluid of thickness  $\varepsilon$  and surface  $S$  is set in a motion under the action of a harmonically vibrating membrane (or plate) with the same surface  $S$  set at its boundaries. This layer is bounded at  $z = \varepsilon$  by the membrane and at  $z = 0$  by a rigid wall. It can also be delimited at its in-plane boundaries  $\bar{w} = \bar{w}_s$  (polar coordinates in the  $z = 0$  plane) by “expansion volumes” for example (Figure 3.7). The thickness  $\varepsilon$  can be considered very small and equal to the thickness of the viscous and thermal boundary layers  $\delta_v \approx \sqrt{2\ell'_v/k_0}$  and  $\delta_h \approx \sqrt{2\ell'_h/k_0}$ , respectively. This condition is not a requirement; several hypotheses on the magnitude of  $\varepsilon$  are presented in the following paragraphs.

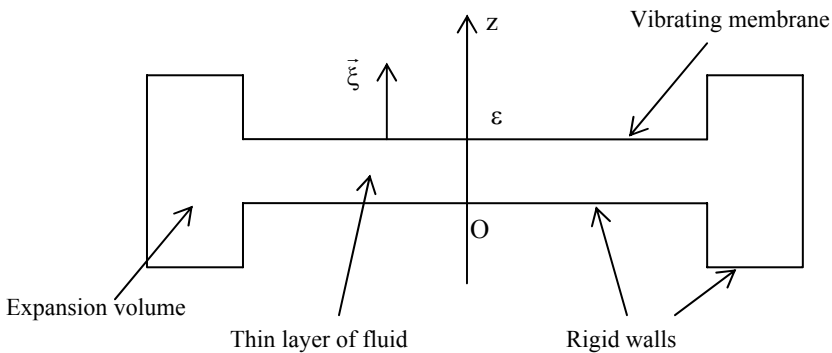

**Figure 3.7.** Thin layer of fluid between a vibrating membrane, a rigid wall and expansion volume

The objective of this section is to provide the reader with the coupled equations of motion of the membrane and fluid layer and to highlight some characteristics of the motions. The considered problem includes the basic equations for the fluid layer: Navier-Stokes (equation (2.30) or equations (2.67) and (2.68)), heat conduction, mass conservation and bivalence of the medium, and one equation for the motion of the membrane. To this system of equations, one needs to add the boundary conditions on the temperature variation and the normal and tangential components of the particle velocity at  $z = 0$ ,  $z = \varepsilon$  and  $\vec{w} = \vec{w}_s$  for the fluid and on the flexural motion of the membrane at  $\vec{w} = \vec{w}_s$ .

The considered configuration and frequency are assumed such that several simplifying hypotheses can be made; they are presented below.

The pressure variation  $p$  is quasi-uniform in the  $z$ -direction perpendicular to the plates, so that it depends only on the tangential components  $\vec{w}$ . The normal gradient  $\partial p / \partial z$  is therefore negligible compared to the tangential gradient  $\vec{\nabla}_{\vec{w}} p$ . Consequently, consideration the  $z$  component of the Navier-Stokes equation leads to the conclusion that the  $z$ -component of the particle velocity is negligible compared with its  $\vec{w}$ -components, thus

$$\vec{v} \approx \vec{v}_{\vec{w}}(\vec{w}, z). \quad (3.78)$$

Also, since the shear viscosity effects when the fluid is oscillating between the two walls at  $z = 0$  and  $z = \varepsilon$  are significant, the spatial variation of the particle velocity  $\vec{v}_{\vec{w}}(\vec{w}, z)$  in the  $z$ -direction is much greater than the spatial variation in the  $\vec{w}$  direction,

$$\left| \vec{\nabla}_{\vec{w}} \vec{v}_{\vec{w}}(\vec{w}, z) \right| \ll \left| \frac{\partial}{\partial z} \vec{v}_{\vec{w}}(\vec{w}, z) \right|. \quad (3.79)$$

Consequently, the volume viscosity factor is negligible when compared to the shear viscosity factor. All remarks considered, the Navier-Stokes equation can be reduced to a relationship between the two  $\vec{w}$ -components, the time factor  $e^{i\omega t}$  being suppressed, which is

$$\left[ \frac{1}{c_0} \frac{\partial}{\partial t} - \ell'_v \frac{\partial^2}{\partial z^2} \right] \vec{v}_{\vec{w}}(\vec{w}, z) = - \frac{1}{\rho_0 c_0} \vec{\nabla}_{\vec{w}} p(\vec{w}), \quad \forall z \in (0, \varepsilon), \quad \forall \vec{w} \in (0, \vec{w}_s). \quad (3.80)$$

This differential equation in the  $z$ -direction satisfied by the particle velocity is completed by two boundary conditions,

$$\vec{v}_{\vec{w}}(\vec{w}, 0) = \vec{v}_{\vec{w}}(\vec{w}, \varepsilon) = 0 \quad \text{and} \quad \forall \vec{w} \in (0, \vec{w}_s). \quad (3.81)$$

The solution to this problem (3.80) and (3.81) is

$$\vec{v}_{\vec{w}} = -\frac{1}{i\rho_0\omega} \vec{\nabla}_{\vec{w}} p(\vec{w}) \left[ 1 - \frac{\cos k_v(z - \varepsilon/2)}{\cos k_v \varepsilon/2} \right]. \quad (3.82)$$

The average value of this solution over the thickness of the fluid layer can be written as

$$\langle \vec{v}_{\vec{w}}(\vec{w}, z) \rangle = \frac{1}{\varepsilon} \int_0^\varepsilon \vec{v}_{\vec{w}} dz = \frac{-1}{i\rho_0\omega} \vec{\nabla}_{\vec{w}} p(\vec{w}) \left[ 1 - \frac{\text{tg } k_v \varepsilon/2}{k_v \varepsilon/2} \right]. \quad (3.83)$$

(All  $z$ -dependent quantities can be, in first approximation, replaced by their average value over the thickness  $\varepsilon$  of the fluid layer.)

The mass conservation law (second equation introduced here) takes the following form

$$i\omega\rho' + \rho_0 \vec{\nabla}_{\vec{w}} \cdot \vec{v}_{\vec{w}}(\vec{w}, z) = -\rho_0 \frac{i\omega\xi S}{\varepsilon S},$$

where the right-hand side term represents the volume of matter introduced per unit of time ( $-i\omega\xi S$ ) and per unit of volume (factor  $\varepsilon S$ ), and acts as a condition at the interface membrane/fluid on the normal component of the particle displacement. Its average value over the thickness  $\varepsilon$  is

$$\vec{\nabla}_{\vec{w}} \cdot \langle \vec{v}_{\vec{w}}(\vec{w}, z) \rangle + \frac{i\omega\xi}{\varepsilon} = -\frac{i\omega}{\rho_0} \langle \rho' \rangle. \quad (3.84)$$

The third equation introduced here expresses  $\rho'$  as an exact total differential (linearized equation (1.23)); the average value over  $\varepsilon$  is

$$\langle \rho' \rangle = \frac{\gamma}{c_0^2} [p - \hat{\beta} \langle \tau \rangle]. \quad (3.85)$$

The fourth and last equation required to solve this four-variables problem ( $p, \rho', \tau, \vec{v}_{\vec{w}}$ ) is the equation of heat conduction. Unlike the amplitude of the pressure variation  $p(\vec{w})$ , the temperature variation  $\tau$  vanishes at the boundaries  $z=0$  and  $z=\varepsilon$ , and is proportional to the pressure  $p(\vec{w})$  away from these boundaries. Therefore, it depends on the variables  $\vec{w}$  and  $z$  satisfying, like the particle velocity, the condition (3.79). Consequently, the equation of heat conduction (2.66) can be approximated to

$$\left[ \frac{1}{c_0} \frac{\partial}{\partial t} - \ell_h \frac{\partial^2}{\partial z^2} \right] \tau(\vec{w}, z) = \frac{\gamma-1}{\hat{\beta}\gamma} \frac{1}{c_0} \frac{\partial p(\vec{w})}{\partial t}, \quad (3.86)$$

$$\forall z \in (0, \varepsilon), \forall \vec{w} \in (0, \vec{w}_s).$$

The solution to equation (3.86), satisfying the boundary conditions

$$\tau(\bar{w}, 0) = \tau(\bar{w}, \varepsilon) = 0, \quad (3.87)$$

can be written as

$$\tau(\bar{w}, z) = \frac{\gamma - 1}{\hat{\beta}\gamma} p(\bar{w}) \left[ 1 - \frac{\cos k_h \left( z - \frac{\varepsilon}{2} \right)}{\cos k_h \frac{\varepsilon}{2}} \right], \quad (3.88)$$

and its average value over the thickness  $\varepsilon$  of the fluid layer is given by

$$\langle \tau \rangle = \frac{\gamma - 1}{\hat{\beta}\gamma} p(\bar{w}) \left[ 1 - \frac{\text{tg } k_h \frac{\varepsilon}{2}}{k_h \frac{\varepsilon}{2}} \right]. \quad (3.89)$$

Before writing the equation of motion of the membrane, equations (3.83), (3.84), (3.85) and (3.89) are combined to eliminate three of the four variables. Combining equation (3.89) with equation (3.85) yields

$$p = c^2 \langle p' \rangle, \quad (3.90)$$

$$\text{where } \frac{1}{c^2} = \frac{\rho_0 \chi_T}{\gamma} \left[ 1 + (\gamma - 1) \frac{\text{tg } k_h \frac{\varepsilon}{2}}{k_h \frac{\varepsilon}{2}} \right]. \quad (3.91)$$

The factor  $1/c^2$  introduces a complex factor of compressibility (since  $k_h$  is complex), as the intermediary between the adiabatic behavior (represented by  $\rho_0 \chi_T / \gamma$ ) and the isothermal behavior, the difference between those two behaviors being represented by the factor  $(\gamma - 1)$ . In the particular case where the fluid is not heat conducting ( $k_h \rightarrow \infty$ ),  $1/c^2 = \rho_0 \chi_T / \gamma = \rho_0 \chi_S$  (the motion is adiabatic) and in the case of high heat conductivity (or at very low frequencies) ( $k_h \rightarrow 0$ ),  $1/c^2 = \rho \chi_T$  (the motion is isothermal).

The substitution of equation (3.90) into (3.84), and the result into the divergence  $\bar{\nabla}_{\bar{w}}$  of equation (3.83), leads directly to

$$\left[ (1 - \varsigma_v) \Delta_{\bar{w}} + \frac{\omega^2}{c^2} \right] p(\bar{w}) = - \frac{\rho_0 \omega^2}{\varepsilon} \xi(\bar{w}), \quad (3.92)$$

where  $c^2$  is given by equation (3.91), and where

$$\varsigma_v = \text{tg} \left( k_v \frac{\varepsilon}{2} \right) / \left( k_v \frac{\varepsilon}{2} \right). \quad (3.93)$$

Equation (3.93) is now coupled with the equation of motion of the membrane:

$$\left[ O + K^2 \right] \xi(\bar{w}) = p(\bar{w}), \quad (3.94)$$

where  $O$  denotes the operator of the membrane (or plate) and  $K$  the wavenumber.

The constants of integration in the solution to the system of equations (3.92) and (3.94) are determined by imposing the boundary conditions that have not yet been used. These are the boundary conditions of the membrane and the acoustic condition at the interface  $\bar{w} = \bar{w}_s$  on the temperature (more precisely its relationship with the pressure) and the particle velocity  $\bar{v}_{\bar{w}}(\bar{w}_s, z)$  normal to the interface (mixed condition relating the velocity to the pressure). These conditions are introduced by the nature of the peripheral expansion volume. A complete study of this is not given here.

In the following paragraph, the study is limited to the case where the membrane is replaced by a rigid wall. Equation (3.94) is not needed anymore and the propagation equation (3.92) for the pressure amplitude  $p$  can be written, considering  $\xi = 0$ , as

$$(\Delta_{\bar{w}} + \chi^2) p(\bar{w}) = 0, \quad (3.95)$$

$$\text{with } \chi^2 = k_0^2 \frac{1 + (\gamma - 1) \frac{\text{tg } k_h \varepsilon / 2}{k_h \varepsilon / 2}}{1 - \frac{\text{tg } k_v \varepsilon / 2}{k_v \varepsilon / 2}} \quad \text{where } k_0 = \frac{\omega}{c_0}. \quad (3.96)$$

### ***Particular case of a capillary slit***

In the particular case of one-dimensional wave propagation when the thickness  $\varepsilon$  is small enough so that the argument  $(k_h \varepsilon / 2)$  is significantly inferior to one (as capillary tubes are defined by very small rectangular cross-sections), the expansion of the first term at the origin leads to the expression of the square of the propagation constant

$$\chi^2 = -i\gamma k_0^2 \frac{3\ell'_v}{k_0(\varepsilon/2)^2}. \quad (3.97)$$

The factor  $\gamma k_0^2 = \frac{\omega^2}{c_0^2 / \gamma} = \rho_0 \chi_T \omega^2$  highlights the isothermal nature of the propagation through the slit and dissipation by heat transfer with the wall that reaches its maximum value. Nevertheless, it is the shear viscosity effect that dominates.

Writing the propagation constant in a form that introduces the speed of propagation  $c_\varepsilon$  and the attenuation factor  $\Gamma$

$$\chi = \frac{\omega}{c_\varepsilon} - i\Gamma, \quad (3.98)$$

one obtains the (commonly-used) following results:

$$c_\varepsilon = \frac{\varepsilon}{2} \sqrt{\frac{2\rho_0\omega}{3\gamma\mu}} c_0 \ll c_0, \quad (3.99)$$

$$\Gamma = \frac{1}{\varepsilon/2} \sqrt{\frac{3\gamma k_0 \mu}{2\rho_0 c_0}} \gg k_0 = \frac{\omega}{c_0}, \text{ thus } \Gamma \lambda_0 \gg 1, \quad (3.100)$$

where  $\lambda_0 = 2\pi/k_0$  denotes the adiabatic wavelength associated to the frequency  $\omega/2\pi$  in infinite space.

The propagation in a capillary slit is characterized by a propagation speed  $c_\varepsilon$  much lower than the adiabatic speed  $c_0$  in infinite space, and by a great attenuation ( $\Gamma$ ) during the propagation. This isothermal process is more like a diffusion process than a propagation one.

Note: equation (3.80) can be replaced by equations (2.67) and (2.68), the solutions for which correspond respectively to the two terms of the solution (3.82), the total particle velocity  $\vec{v}_{\vec{w}}$  then being written as  $\vec{v}_{\vec{w}} = \vec{v}_{\ell_{\vec{w}}} + \vec{v}_{\nu_{\vec{w}}}$ .

### 3.7. Harmonic plane wave propagation in cylindrical tubes: propagation constants in “large” and “capillary” tubes

A plane wave is propagating in an infinite cylindrical tube with circular cross-section. The shell of the tube is assumed first axis-symmetrically vibrating (Figure 3.8).

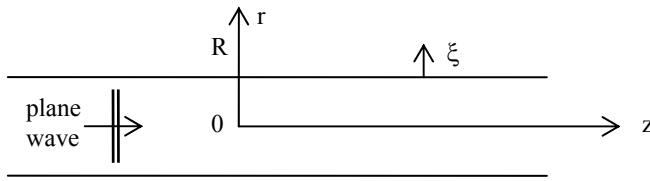

**Figure 3.8.** Propagation of a plane wave in a tube of circular cross-section

Once again, the objective of this analysis is to provide the reader with the coupled equations of motion of the shell and the column of fluid. The motion of the fluid in presence of thermo-viscous phenomena is emphasized. The basic equations used are the same as those previously used (the Navier-Stokes equation, mass conservation, heat conduction and bivariate of the fluid). The boundary conditions impose continuity at the interface shell/fluid ( $r = R$ ) of the temperature variation  $\tau(R, z) = 0$  and particle velocity  $v_z(R, z) = 0$  (the boundary condition on the normal velocity being reported in the form of source terms in the equation of mass conservation since the approximations considered herein cancel it out in the Navier-Stokes equation).

Several simplifying hypothesis can be made and will be presented when needed. First, the pressure variation, being (quasi-) uniform over a tube section, is considered independent of the radial coordinate  $r$ . Consequently, the radial component of the pressure gradient is, unlike the radial component of the particle velocity, ignored (resulting from the projection of the Navier-Stokes equation onto the radial axis).

Moreover, since the shear viscosity effects are important, the variation of particle velocity  $v = v_z$  along the variable  $r$  is much greater than its equivalent in the  $z$ -direction:

$$\left| \frac{\partial}{\partial z} v_z(r, z) \right| \ll \left| \frac{\partial}{\partial r} v_z(r, z) \right|. \tag{3.101}$$

This implies, in particular, that the factor relating to the bulk viscosity can be ignored. Finally, only the axial component of the Navier-Stokes equation (equation (2.30) for instance, or equations (2.67) and (2.68)) needs to be considered. Its takes the following approximated form:

$$\left[ \frac{1}{c_0} \frac{\partial}{\partial t} - \ell'_v \frac{1}{r} \frac{\partial}{\partial r} r \frac{\partial}{\partial r} \right] v_z(\bar{r}, z) = \frac{-1}{\rho_0 c_0} \frac{\partial}{\partial z} p(z), \quad \forall r \in (0, R), \quad \forall z. \tag{3.102}$$

To this differential equation (on the variable  $z$ ) are associated the two conditions on the  $z$  component of the particle velocity

$$v_z(0, z) \text{ remains finite and } v_z(R, z) = 0, \forall z. \quad (3.103)$$

The solution to the set of equations (3.102) and (3.103) can be written, in the frequency domain, as

$$v_z(\vec{r}, z) = \frac{i}{k_0 \rho_0 c_0} \frac{\partial}{\partial z} p(z) \left[ 1 - \frac{J_0(k_v r)}{J_0(k_v R)} \right] \quad (3.104)$$

(where  $J_0$  is the 0<sup>th</sup>-order cylindrical Bessel's function of the first kind) and its average value over the section of the tube is

$$\langle v_z \rangle = \frac{1}{\pi R^2} \int_0^R 2\pi r v_z dr = \frac{i}{k_0 \rho_0 c_0} \frac{\partial p(z)}{\partial z} \left[ 1 - \frac{2}{k_v R} \frac{J_1(k_v R)}{J_0(k_v R)} \right], \quad (3.105)$$

where  $J_1$  is the 1<sup>st</sup>-order cylindrical Bessel's function of the first kind.

The second equation, equation of mass conservation, takes the following form:

$$i\omega \rho' + \rho_0 \frac{\partial}{\partial z} v_z(r, z) = -\rho_0 i\omega \xi(z) \frac{2}{R}, \quad (3.106)$$

where the right-hand side term represents the volume of matter introduced per unit of time and volume (the factor  $2/R$  is the ratio of the area of the surface of the shell to the corresponding volume for any given length of tube). The expression of the right-hand side term fulfils the condition on the displacement normal to the  $r = R$  interface.

The average value of this equation over a section of the tube is written, as

$$\frac{\partial}{\partial z} \langle v_z \rangle + i \frac{2\omega}{R} \xi = -\frac{i\omega}{\rho_0} \langle \rho' \rangle. \quad (3.107)$$

The average value over the section of tube that expresses the total differential of  $\rho'$  (the third equation) is

$$\langle \rho' \rangle = \frac{\gamma}{c_0^2} (p - \hat{\beta} \langle \tau \rangle). \quad (3.108)$$

The fourth and last equation to introduce is the equation of heat conduction. Since the temperature variation  $\tau$  vanishes at  $r = R$ , it only depends on the



variables  $r$  and  $z$  so that, as the particle velocity does, it satisfies equation (3.101). Consequently, the equation of heat conduction (2.66) can be approximated as

$$\left[ \frac{1}{c_0} \frac{\partial}{\partial t} - \ell_h \frac{1}{r} \frac{\partial}{\partial r} \left( r \frac{\partial}{\partial r} \right) \right] \tau(r, z) = \frac{\gamma-1}{\hat{\beta}\gamma} \frac{1}{c_0} \frac{\partial}{\partial t} p(z), \quad \forall (r, z). \quad (3.109)$$

The solution to such equation that satisfies the following boundary conditions  $\tau(0, z)$  remains finite and  $\tau(R, z) = 0$ ,  $\forall z$ , is

$$\tau = \frac{\gamma-1}{\hat{\beta}\gamma} p(z) \left[ 1 - \frac{J_0(k_h r)}{J_0(k_h R)} \right]. \quad (3.110)$$

Its average value over the section of the tube is then

$$\langle \tau \rangle = \frac{\gamma-1}{\hat{\beta}\gamma} p(z) \left[ 1 - \frac{2}{k_h R} \frac{J_1(k_h R)}{J_0(k_h R)} \right]. \quad (3.111)$$

With this set of equations governing the motion of the fluid, one needs to associate the equation of axis-symmetrical motion of the shell and its boundary conditions (not specified herein). The equation for the shell is

$$(O + K^2) \xi(z) = p(z), \quad (3.112)$$

where  $O$  denotes the operator of the shell and  $K$  is the wavenumber.

The set of equations (3.105), (3.107), (3.108) and (3.111) is used to find the solution in terms of pressure field coupled to the shell equation (3.112). The substitution of equation (3.111) into equation (3.108) yields

$$p = c^2 \langle \rho' \rangle, \quad (3.113)$$

$$\text{with } \frac{1}{c^2} = \frac{\rho_0 \chi_T}{\gamma} \left[ 1 + (\gamma-1) \frac{2}{k_h R} \frac{J_1(k_h R)}{J_0(k_h R)} \right]. \quad (3.114)$$

This complex speed “ $c$ ” introduces the phenomenon of relaxation associated with the fluid compressibility. It is associated with the adiabatic speed  $(\rho_0 \chi_T / \gamma)^{1/2}$  if the thermal conduction of the fluid is ignored ( $\ell_h \rightarrow 0$ ) and with the isothermal speed  $(\rho_0 \chi_T)^{1/2}$  if the thermal conduction is important ( $\ell_h \rightarrow \infty$ ).

Finally, the substitution of equation (3.111) into equation (3.107) and the resulting expression into the derivative of equation (3.105) with respect to  $z$  leads to

$$\left[ (1 - K_v) \frac{\partial^2}{\partial z^2} + \frac{\omega^2}{c^2} \right] p(z) = -\frac{\rho_0 \omega^2}{R/2} \xi, \quad (3.115)$$

where  $c^2$  is given by equation (3.114) and where  $K_v = \frac{2}{k_v R} \frac{J_1(k_v R)}{J_0(k_v R)}$ .

The object of the following derivation is limited to the study of the propagation constant (propagation speed and attenuation) for plane waves in a tube the walls of which are assumed now to be perfectly rigid.

Equation (3.115) for the amplitude of the pressure  $p$  becomes (knowing that  $\xi = 0$ )

$$\left( \frac{\partial^2}{\partial z^2} + k_z^2 \right) p(z) = 0, \quad (3.116)$$

$$\text{with } k_z^2 = k_0^2 \frac{1 + (\gamma - 1)K_h}{1 - K_v}, \quad (3.117)$$

$$\text{where } K_{h,v} = \frac{2}{k_{h,v} R} \frac{J_1(k_{h,v} R)}{J_0(k_{h,v} R)}.$$

The ratio  $2/R$  represents the ratio of the perimeter to the area of the cross-section of the tube.

### ***Particular case of the “large” tube***

In waveguides where the radius  $R$  is much greater than the thickness of the boundary layers, the asymptotic expansion to the  $1/2^{\text{th}}$ -order of the characteristic lengths  $\ell'_v$  and  $\ell_h$  gives

$$k_z^2 \approx k_0^2 \left[ 1 + \frac{1-i}{\sqrt{2}} \frac{2}{R} \frac{1}{\sqrt{k_0}} \left( \sqrt{\ell'_v} + (\gamma-1)\sqrt{\ell_h} \right) \right], \quad k_0 = \frac{\omega}{c_0}. \quad (3.118)$$

This relation is very often used. It is to be compared to equation (2.86)

$$k_a^2 \approx k_0^2 (1 - ik_0 [\ell_v + (\gamma-1)\ell_h]), \quad (3.119)$$

that represents the square of the wavenumber of the plane wave in an infinite space. The factor  $[\ell_v + (\gamma-1)\ell_h]$  is of magnitude  $10^{-7}$  for air in normal conditions while the factor  $\left[ \sqrt{\ell'_v} + (\gamma-1)\sqrt{\ell_h} \right]$  is of magnitude  $3 \cdot 10^{-4}$ , and consequently far greater.

By introducing the propagation speed  $c_t$  and the attenuation factor  $\Gamma$  in the propagation constant,

$$k_z = \frac{\omega}{c_t} - i\Gamma, \quad (3.120)$$

one obtains the (commonly used) results:

$$c_t = c_0 \left[ 1 - \frac{1}{R\sqrt{2k_0}} \left[ \sqrt{\ell'_v} + (\gamma-1)\sqrt{\ell'_h} \right] \right] \approx c_0, \quad (3.121)$$

$$\Gamma = \frac{1}{R} \sqrt{\frac{k_0}{2}} \left[ \sqrt{\ell'_v} + (\gamma-1)\sqrt{\ell'_h} \right]. \quad (3.122)$$

This attenuation factor is significantly greater than that for a plane wave in an infinite space, denoted  $\Gamma_\infty$  (equation (3.119))

$$\Gamma_\infty = \frac{k_0^2}{2} [\ell_v + (\gamma-1)\ell_h]. \quad (3.123)$$

### ***Particular case of the “capillary” tube***

For the tubes for which radii are small compared to the thickness of the visco-thermal boundary layers (capillary tubes), the expansion at the vicinity of the origin of the functions  $K_{v,h}$  gives

$$k_z \approx \sqrt{\gamma}k_0(1-i) \frac{2}{R} \sqrt{\frac{\ell'_v}{k_0}} = (1-i) \frac{2}{R} \sqrt{\gamma k_0 \ell'_v}, \quad (3.124)$$

where  $\sqrt{\gamma}k_0 = \frac{\omega}{c_0/\gamma}$  translates the isothermal property of the propagation.

Therefore, for capillary tubes,

$$c_t \approx \frac{R}{2} \sqrt{\frac{k_0}{\gamma \ell'_v}} c_0 \ll c_0, \quad (3.125)$$

$$\Gamma \approx \frac{2}{R} \sqrt{\gamma k_0 \ell'_v} \gg k_0 = \frac{\omega}{c_0} \text{ thus } \Gamma \lambda_0 \gg 1, \quad (3.126)$$

where  $\lambda_0 = 2\pi/k_0$  represents the wavelength of the adiabatic wave associated to the frequency  $(\omega/2\pi)$  in an infinite space.

Propagation in capillary tubes is characterized by a propagation speed  $c_t$  much lower than the adiabatic speed  $c_0$  in infinite space, and by a very important attenuation  $\Gamma$  during the propagation. The isothermal process is more like a diffusion process than a propagation one.

**Note: Hagen-Poiseuille equation**

The approximated Navier-Stokes equation used in this chapter (equations (3.80) and (3.102)) is nothing more than the Hagen-Poiseuille equation. To verify this in a cylindrical case, one only needs to consider the portion of fluid between two cylinders of respective radii  $r$  and  $r + dr$ , and of length  $dz$  (Figure 3.9).

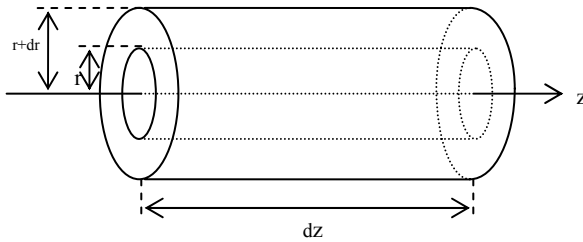

**Figure 3.9.** Layer of fluid of thickness  $dr$

The viscous shear force along the  $z$ -axis applied to the fluid element at the interface  $r$  can be written as

$$-\mu 2\pi r dz \frac{\partial}{\partial r} v_z(r), \quad (3.127)$$

and the force applied at  $r + dr$  on the same fluid element is

$$\mu 2\pi (r + dr) dz \frac{\partial}{\partial r} v_z(r + dr). \quad (3.128)$$

The fundamental equation of dynamics introduces the sum of both forces and relates it to the difference of pressures at both ends of the fluid element; therefore

$$\rho_0 \frac{\partial v_z}{\partial t} = -\frac{\partial p}{\partial z} + \frac{\mu}{r} \frac{\partial}{\partial r} \left( r \frac{\partial v_z}{\partial r} \right), \quad (3.129)$$

$$\text{thus } \left[ \frac{1}{c_0} \frac{\partial}{\partial t} - \ell_v \frac{1}{r} \frac{\partial}{\partial r} \left( r \frac{\partial}{\partial r} \right) \right] v_z = -\frac{1}{\rho_0 c_0} \frac{\partial p}{\partial z}. \quad (3.130)$$

This is nothing more than equation (3.102).

### 3.8. Guided plane wave in dissipative fluid

This section, similar to section 3.2 (reflection of plane harmonic waves on an infinite rigid wall) and section 3.7 (propagation of plane harmonic waves in cylindrical tube), enunciates differently and completes the previous problems to summarize the conclusions drawn in these sections.

An acoustic harmonic wave propagates in a dissipative gas (viscous and heat conducting) contained in a cylindrical tube with a circular cross-section of radius  $R$ . The walls of the waveguide are considered rigid. The frequency  $f$  of the propagating wave is smaller than the first cut-off frequency  $f_0$  of the tube (this notion is explained in Chapter 4); there is consequently an upper limit to the value of  $R$  for which one can, *a posteriori*, justify the hypothesis that the dissipation within the fluid remains negligible compared to the dissipation due to the boundary layers. However, the radius of the tube remains significantly greater than the thickness of the viscous and thermal boundary layers, so that the acoustic pressure can be considered quasi-plane (quasi-uniform over any given section of the tube, very slowly dependent on the radial coordinate  $r$ , for example) and independent, by symmetry, of the azimuth  $\theta$ , and propagating along the  $Oz$  axis.

There are two objectives to this section: first to show that the propagation occurs as if the dissipation due to the boundary layers was related to a non-null admittance of the walls, function of the viscosity and thermal conduction coefficients (equation (3.10)), and then to give the expression of the propagation constant  $k_z$  (equation (3.118)) and verify that it includes most of the dissipation.

Note: the notations have all been presented in the second chapter and will therefore not be detailed in this section. The time factor  $e^{i\omega t}$  is suppressed throughout.

The hypotheses made and the relative magnitudes of the considered constants lead to

$$k_h^2 = k_{hr}^2 + k_z^2, \quad (3.131a)$$

$$\text{with: } |k_z| \ll |k_h|, \quad (3.131b)$$

$$\text{thus: } k_{hr}^2 \sim k_h^2 = -ik_0/\ell_h, \quad (3.131c)$$

$$k_v^2 = k_{vr}^2 + k_z^2, \quad (3.132a)$$

$$\text{with: } |k_z| \ll |k_v|, \quad (3.132b)$$

$$\text{thus: } k_{vr}^2 \sim k_v^2 = -ik_0/\ell_v, \quad (3.132c)$$

$$k_a^2 = k_{ar}^2 + k_z^2, \quad (3.133a)$$

$$\text{with: } |k_{ar}| \ll |k_z|, \quad (3.133b)$$

$$R \gg \sqrt{\frac{2\ell'_v}{k_0}}, \sqrt{\frac{2\ell_h}{k_0}}, \quad (3.134a)$$

$$f < f_0 = \frac{1.84 c_0}{2\pi R} \quad (\text{equations (5.50b) and (5.47b)}). \quad (3.134b)$$

The solutions considered are solutions to equations (2.80) and (2.81) and can be written as

$$p \approx p_a = p_0 \frac{J_0(k_{ar} r)}{J_0(k_{ar} R)} \exp(-ik_z z), \quad (3.135)$$

$$\tau_a \approx \frac{\gamma-1}{\hat{\beta}\gamma} p_0 \frac{J_0(k_{ar} r)}{J_0(k_{ar} R)} \exp(-ik_z z), \quad (3.136a)$$

$$\tau_h \approx A_h \exp[-ik_{hr}(R-r)] \exp(-ik_z z), \quad (3.136b)$$

where the function  $\exp[-ik_{hr}(R-r)]$  is an approximation of the Bessel's function  $J_0[k_{hr}(R-r)]$  assuming that the cylinder can, on a scale of magnitude similar to that of the thicknesses of the boundary layers, be approximated by its tangent plane, as far as the motions of entropic diffusion ( $\tau_h$ , above) and vortical diffusion ( $v_v$ , below) are concerned:

$$v_{\ell z} = -ik_z \left[ \frac{i\gamma\hat{\beta}}{(\gamma-1)k_0\rho_0 c_0} \tau_a + \frac{\gamma\hat{\beta}\ell_h}{\rho_0 c_0} \tau_h \right], \quad (3.137a)$$

$$v_{\ell r} = \frac{i\gamma\hat{\beta}}{(\gamma-1)k_0\rho_0 c_0} \frac{\partial}{\partial r} \tau_a + ik_{hr} \frac{\gamma\hat{\beta}\ell_h}{\rho_0 c_0} \tau_h, \quad (3.137b)$$

$$v_{vz} = A_v \frac{k_{vr}}{k_z} \exp[-ik_{vr}(R-r)] \exp(-ik_z z), \quad (3.138a)$$

$$v_{vr} = -A_v \exp[-ik_{vr}(R-r)] \exp(-ik_z z). \quad (3.138b)$$

The boundary conditions ( $r = R$ ) can be written as

$$\tau(R, z) = 0, \text{ thus } A_h + \frac{\gamma-1}{\gamma\hat{\beta}} p_0 = 0, \quad (3.139a)$$

$$v_z(R, z) = 0, \text{ thus } -ik_z \left[ \frac{i}{k_0\rho_0 c_0} p_0 + \frac{\gamma\hat{\beta}\ell_h}{\rho_0 c_0} A_h \right] + A_v \frac{k_{vr}}{k_z} \approx 0, \quad (3.139b)$$

$$v_r(R, z) = 0, \text{ thus } v_{0r}(k_{ar}R) + ik_{hr} \frac{\gamma \hat{\beta} \ell_h}{\rho_0 c_0} A_h + A_v = 0, \quad (3.139c)$$

where

$$v_{0r}(k_{ar}R) = \frac{ik_{ar}}{\rho_0 c_0 k_0} \frac{J_1(k_{ar}R)}{J_0(k_{ar}R)} p_0 \approx \frac{ik_{ar}^2 R}{2\rho_0 c_0 k_0} p_0$$

(expansion at the origin) (3.140)

denotes the radial component of the acoustic particle velocity at the vicinity of the wall.

At an order of half the characteristic lengths  $\ell'_v$  and  $\ell_h$ , these three equations (3.139) lead directly to the expression of the equivalent specific acoustic “admittance” of the wall, in clear analogy with that given by equation (3.10):

$$\frac{\rho_0 c_0}{Z_a} = \frac{\rho_0 c_0 v_{0r}(k_{ar}R) \exp(-ik_z z)}{p_a},$$

$$\approx \sqrt{ik_0} \left[ \left( 1 - \frac{k_{ar}^2}{k_0^2} \right) \sqrt{\ell'_v} + (\gamma - 1) \sqrt{\ell_h} \right]. \quad (3.141)$$

Equation (3.141) shows that the properties of the viscous and thermal boundary layers can be taken into account in terms of an equivalent impedance of the wall. This observation is particularly useful in modal theory in dissipative fluids for propagating or evanescent modes (see Chapters 4 and 5).

Note that

$$1 - \frac{k_{ar}^2}{k_0^2} \approx \frac{k_z^2}{k_0^2} \quad (3.142)$$

remains close to the unit (grazing incidence).

Moreover, the substitution of the expression (3.140) of  $v_{0r}$  into equation (3.141) and consideration of equation (3.142) leads to

$$\frac{k_z^2}{k_0^2} \approx 1 + (1-i) \frac{\sqrt{2}}{\sqrt{k_0 R}} \left[ \sqrt{\ell'_v} + (\gamma - 1) \sqrt{\ell_h} \right], \quad (3.143)$$

that is, equation (3.118) as expected.

By recalling the propagation constant of a plane wave in infinite space (equation 2.86)

$$k_a^2 = k_0^2 (1 - ik_0 \ell_{vh}),$$

it appears that the dissipation factor associated with the wavenumber  $k_a$  in infinite space remains smaller than the one associated with the constant  $k_z$  (above) as long as the radius of the tube is small,

$$R \ll \frac{1}{k_0^{3/2} \sqrt{\ell_{v,h}}}. \quad (3.144)$$

This equation is compatible with the inequalities (3.134a) and (3.134b) stating that the radius of the tube is assumed to be considerably greater than the thickness of the boundary layers since, often in practice,

$$\sqrt{\frac{\ell_{v,h}}{k_0}} \ll R < \frac{1.84 c_0}{2\pi f} = \frac{1.84}{k_0} \ll \frac{1}{k_0^{3/2} \sqrt{\ell_{v,h}}}. \quad (3.145)$$

### 3.9. Cylindrical waveguide, system of distributed constants

The problem of plane wave propagation in cylindrical tubes with circular cross-sections considered in sections 3.7 and 3.8 can be treated as an analogy with the theory of (electric) lines with distributed constants. Indeed, by considering equation (3.105) associated with the set of equations (3.107), (3.108) and (3.111) which are combined to eliminate the variables  $\langle \rho' \rangle$  and  $\langle \tau \rangle$ , one can reduce the set of equations and the boundary conditions to the following couple of equations:

$$\frac{\partial p(z)}{\partial z} = - \frac{ik_0 \rho_0 c_0}{1 - K_v} \langle v \rangle, \text{ with } K_v = \frac{2}{k_v R} \frac{J_1(k_v R)}{J_0(k_v R)}, \quad (3.146)$$

$$\frac{\partial \langle v \rangle}{\partial z} = - \frac{ik_0}{\rho_0 c_0} [1 + (\gamma - 1)K_h] p(z) \text{ with } K_h = \frac{2}{k_h R} \frac{J_1(k_h R)}{J_0(k_h R)}. \quad (3.147)$$

By denoting  $u = S \langle v \rangle$  ( $S$  being the cross-sectional area of the tube),

$$Z_v = \frac{1}{S} \frac{ik_0 \rho_0 c_0}{1 - K_v} \text{ and } Y_h = S \frac{ik_0}{\rho_0 c_0} [1 + (\gamma - 1)K_h], \quad (3.148)$$



equations (3.146) and (3.147) become

$$\frac{\partial}{\partial z} p + Z_v u = 0, \quad (3.149)$$

$$\frac{\partial}{\partial z} u + Y_h p = 0, \quad (3.150)$$

or

$$dp + Z_v dz u = 0, \quad (3.151)$$

$$du + Y_h dz p = 0. \quad (3.152)$$

The associated equations of propagation are then

$$\frac{\partial^2 p}{\partial z^2} + k_z^2 p = 0 \quad \text{and} \quad \frac{\partial^2 u}{\partial z^2} + k_z^2 u = 0, \quad (3.153)$$

where

$$k_z^2 = -Z_v Y_h = k_0^2 \frac{1 + (\gamma - 1) K_h}{1 - K_v} \quad (\text{equation (3.117)}). \quad (3.154)$$

The impedance (qualified as “iterative”)  $Z_i = p/u$  and the corresponding admittance  $Y_i = u/p$  of the line are directly obtained from equations (3.146) and (3.147) by writing  $\partial/\partial z = \pm ik_z$  (from equation (3.153)). Thus

$$Z_i = \frac{\rho_0 c_0}{S \sqrt{(1 - K_v)[1 + (\gamma - 1) K_h]}} \quad \text{and} \quad Y_i = 1/Z_i. \quad (3.155)$$

By adopting the often-made hypotheses that  $|Y_h Z_v| \ll 1$ , the electrical diagram associated with equations (3.149) and (3.150), can be as in Figure 11.33 (section 11.4.2).

The asymptotic expansion of  $K_v$  and  $K_h$  for large tubes ( $|k_{h,v} R| > 10$ ) leads to

$$Z_v \approx \frac{\rho_0 c_0 k_0}{S} \left[ \frac{\sqrt{2\ell'_v}}{R\sqrt{k_0}} + i \left( 1 + \frac{\sqrt{2\ell'_v}}{R\sqrt{k_0}} \right) \right], \quad (3.156)$$

$$Y_h \approx \frac{k_0 S}{\rho_0 c_0} \left[ (\gamma - 1) \frac{\sqrt{2\ell_h}}{R\sqrt{k_0}} + i \left( 1 + (\gamma - 1) \frac{\sqrt{2\ell_h}}{R\sqrt{k_0}} \right) \right], \quad (3.157)$$

where  $S = \pi R^2$ .

The real parts of these expressions reveal the resistive factors due to the viscosity and thermal conduction (within the boundary layers) and the imaginary parts reveal the reactive factor: an inertia factor  $i\omega\rho_0/S$ , corrected by an additional factor due to the viscosity, and an elastic factor  $i\omega S/(\rho_0 c_0^2)$ , corrected by a factor due to the thermal conduction.

To emphasize the importance of these results, one can consider for a very small element  $\ell$  of a tube such that the pressure difference  $\delta p = p_e - p_s$  between the entrance and the exit of the tube is written as

$$\frac{\delta p}{\ell} \approx -\frac{\partial p}{\partial z} = +Z_v u, \quad (3.158)$$

where the axis  $\bar{O}z$  is directed towards the end of the tube. If the radius of the tube is not particularly small, so that the resistance can be ignored, the fluid element considered presents an inertia given by

$$\frac{\delta p}{u} = i\omega \frac{\rho_0 \ell}{S}, \quad (3.159)$$

or, in the time domain, by

$$\delta p = \frac{\rho_0 \ell}{S} \frac{\partial u}{\partial t}. \quad (3.160)$$

The quantity  $m_a = \frac{\rho_0 \ell}{S}$  is called the acoustic mass of the fluid column in the tube and similarly presents an elastic behavior described by

$$\frac{\delta u}{\ell} = -\frac{\partial u}{\partial z} = Y_h p \approx i \frac{\omega S}{\rho_0 c_0^2} p, \quad (3.161)$$

$$\text{or } p = \frac{\rho_0 c_0^2}{i\omega S \ell} \delta u = -\frac{\gamma}{\chi_T} \frac{\delta V}{V} = \frac{\gamma \Xi}{\chi_T V}, \quad (3.162)$$

where  $\Xi$  denotes the product of the fluid displacement by the cross-sectional area  $S$ .

The expression  $\left( -\frac{\gamma}{\chi_T} \frac{\delta V}{V} \right)$  is obtained by considering the behavior of small cavities (equation (3.73)). The ratio  $\frac{\gamma}{\chi_T V} = s_a = \frac{1}{C_a}$  is an acoustic stiffness, reciprocal of the compliance  $C_a$ .

In the case of capillary tubes, the developments of equation (3.149) close to the origin leads to the following results:

$$\frac{\delta p}{u} \approx \frac{8\mu\ell}{\pi R^4} + i \frac{4}{3} \frac{\rho_0\ell}{\pi R^2} \omega \approx \frac{8\mu\ell}{\pi R^4}. \quad (3.163a)$$

The behavior is dominantly resistive  $\left( R_a = \frac{8\mu\ell}{\pi R^4} \right)$ , but presents a small inertial component with  $m_a = \frac{4}{3} \frac{\rho_0\ell}{\pi R^2}$ .

Similarly, for capillary tubes, equation (3.150) leads to

$$\begin{aligned} \frac{\delta u}{p} &\approx (\gamma - 1) k_0^2 \frac{\pi R^4 \ell}{8\lambda / C_P} + i \frac{\gamma \pi R^2 \ell}{\rho_0 c_0^2} \omega, \\ &\approx i \frac{\gamma \pi R^2 \ell}{\rho_0 c_0^2} \omega = i \omega S \ell \chi_T. \end{aligned} \quad (3.163b)$$

The behavior described does not present much interest for a short capillary tube since it is proportional to the ratio of the length  $\ell$  of the tube over the wavelength, which is often very small.

Note: from equations (3.83), (3.84), (3.95) and (3.89) in section 3.6, and by following the above approach, equations (3.146) to (3.163) can be written in the case of parallel walls (but will not be not given here). These results concerning capillary slits of thickness  $h$  and width  $b$  ( $b \gg h$ ) are frequently used and are given by:

$$\frac{\delta p}{u} = Z_v \ell \approx \frac{12\mu\ell}{bh^3} + i \frac{6}{5} \frac{\rho_0\ell}{bh} \omega. \quad (3.164)$$

The behavior is once more dominantly resistive  $\left( R_a = \frac{12\mu\ell}{bh^3} \right)$ , but also presents a small inertial component with  $m_a = \frac{6}{5} \frac{\rho_0\ell}{S}$ .

### 3.10. Introduction to the thermoacoustic engines (on the use of phenomena occurring in thermal boundary layers)

A half-wave tube (working in plane waves mode) is equipped with thin and short parallel plates (stack) that are approximately halfway between a loudspeaker

and the center of the tube where the pressure gradient (in terms of amplitude) is negative ( $dp(x)/dx < 0$ ) (Figure 3.10). The stationary wave (in terms of particle velocity) presents nodes at each end of the tube (first approximation). The distance “L” between the plates is about 3 times the thickness of the boundary layers ( $L \approx 3 \delta_{v,h}$ ). A mean temperature gradient over the length of the plates ( $dT_m/dx$ ), independent of the position  $x$ , varying slowly with time and assumed negative here by hypothesis, is maintained between the ends of the plates. The heat flux established by pure convection between the high temperature ( $T_+$ ) and the lowest temperature ( $T_-$ ) zones is negligible within the time frame considered (one acoustic period).

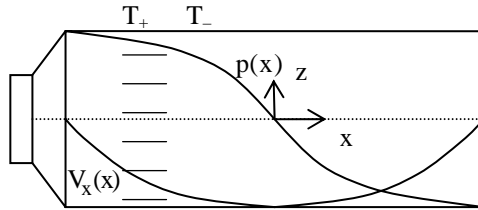

**Figure 3.10.** Half-wave tube equipped of “short” parallel plates (stack) in the region where the gradient of amplitude of the pressure  $p(x)$  is negative

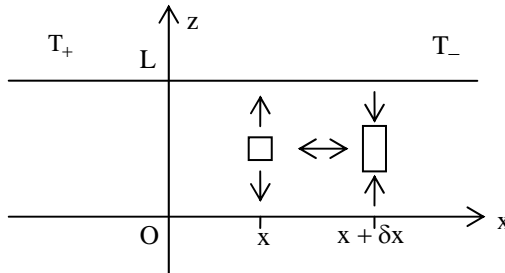

**Figure 3.11.** Interval between two short parallel plates; particle motion ( $\leftrightarrow$ ) and heat transfer ( $\uparrow\downarrow$ )

The object of this section is to study the particle motion within one cell of thickness “L” (Figure 3.11), in the  $(x,y)$ -plane considering that the amplitudes of pressure  $p(x)$  and particle velocity  $v_x(x,y)$  are approximately in quadrature (in the following, the pressure phase  $p(x,t)$  is chosen as the phase reference). Qualitatively, the instantaneous pressure of a particle and its temperature are greater at a given point  $(x)$  than they are at a point  $(x + \delta x, \delta x > 0)$ , so that the particle “drains” heat from the plates (located at  $z=0,L$ ) at the coordinate  $(x + \delta x)$  and (partially) “restitutes it at  $(x)$  if the magnitude of the “static” gradient of temperature ( $\partial T_m / \partial x$ ) remains inferior to a limit value (called critical gradient) in

order to avoid inversion of the heat transfers. Consequently, a continuous heat flux occurs in the direction opposite to the x-axis following a non-linear process and that makes the stack likely to work as a thermo-acoustic heat refrigerator, a heat pump or a thermo-acoustic engine.

To demonstrate the above interpretation, one needs to follow the procedure adopted in section 3.6 by introducing additional factors associated with the mean temperature gradient. A simplified version of this approach is presented here.

The non-linear equation of heat conduction (equation (2.44)) is, here, in the form

$$\rho_m T_m \left( \frac{\partial S}{\partial t} + \vec{v} \cdot \vec{\nabla} S \right) \approx \lambda \Delta T, \quad (3.165)$$

where the index  $m$  indicates that the associated quantity is a mean value over the time period. Thus, by denoting  $S = S_m + s$  where  $s$  represents the entropy variation associated to the particle motion ( $s \ll S_m$ ) and considering only the first order of the acoustic quantities and limiting the analysis to harmonic motions:

$$\rho_m T_m \left( i\omega s + v_x \frac{\partial S_m}{\partial x} \right) \approx \lambda \frac{\partial^2 \tau}{\partial z^2}. \quad (3.166)$$

According the hypotheses made, in equation (3.166), the  $z$ - and  $y$ -components of the particle velocity and the temperature variation along the  $x$ -axis are ignored in the left-hand side term.

By considering equation (1.22)

$$dS = \frac{C_P}{T_m} dT - \frac{\alpha}{\rho_m} dP,$$

that by integration and at first approximation gives

$$s = \frac{C_P}{T_m} \tau - \frac{\alpha}{\rho_m} p \text{ at the 1}^{\text{st}} \text{ order (linear approximation),} \quad (3.167)$$

$$\text{and } dS_m = \frac{C_P}{T_m} dT_m \text{ at the order 0,} \quad (3.168)$$

equation (3.166) becomes

$$\left[ 1 - \frac{c_0 \ell_h}{i\omega} \frac{\partial^2}{\partial z^2} \right] \tau(x, z) = \frac{\alpha T_m}{C_P \rho_m} p(x) - \frac{\partial T_m}{\partial x} \frac{v_x(x, z)}{i\omega}, \quad (3.169)$$

$$\text{where } \frac{c_0 \ell_h}{i\omega} = \frac{\lambda}{i\omega \rho_m C_p} = \frac{1}{2i} \delta_h^2 = -\frac{1}{k_h^2}, \quad (3.169a)$$

where  $\delta_h$  denotes the thickness of the boundary layers, and where

$$\frac{\alpha T_m}{C_p \rho_m} = \frac{C_p - C_v}{C_p \hat{\beta}} = \frac{\gamma - 1}{\hat{\beta} \gamma}. \quad (3.169b)$$

With equation (3.169), one needs to associate the following boundary conditions

$$\tau(x, 0) = \tau(x, L) = 0. \quad (3.170)$$

Within the assumed approximations used in section 3.6, the mean value of Navier-Stokes's solution over a section of the system can be written as

$$\langle v_x \rangle = \frac{-1}{i\omega \rho_m} \frac{\partial p}{\partial x} \left[ 1 - \frac{\text{tg } k_v L/2}{k_v L/2} \right]. \quad (3.171)$$

This mean value is substituted for the function  $v_x$  in equation (3.169) to obtain an approximate solution. This solution, satisfying the boundary conditions (3.170), can be written as

$$\tau = \left[ \frac{\alpha T_m}{C_p \rho_m} p - \frac{\partial T_m}{\partial x} \frac{\langle v_x \rangle}{i\omega} \right] \left[ 1 - \frac{\cos k_h (z - L/2)}{\cos k_h L/2} \right], \quad (3.172)$$

and its mean value over the section of the system takes the following form:

$$\langle \tau \rangle = \left[ \frac{\alpha T_m}{C_p \rho_m} p - \frac{\partial T_m}{\partial x} \frac{\langle v_x \rangle}{i\omega} \right] \left[ 1 - \frac{\text{tg } k_h L/2}{k_h L/2} \right]. \quad (3.173)$$

By hypothesis  $L \approx 3\delta_h$  and  $|k_h L/2| \approx 2.5$ . Therefore, one can limit the asymptotic expansion of the right-hand side term of equation (3.171) and (3.173) to the lowest order, leading to

$$\langle v_x \rangle \approx \frac{-1}{i\omega \rho_m} \frac{\partial p}{\partial x} \left[ 1 - (1-i) \frac{\delta_v}{L} \right] \approx \frac{-1}{i\omega \rho_m} \frac{\partial p}{\partial x}, \quad (3.174)$$

$$\langle \tau \rangle \approx \left[ \frac{\alpha T_m}{C_p \rho_m} p - \frac{\partial T_m}{\partial x} \frac{\langle v_x \rangle}{i\omega} \right] \left[ 1 - (1-i) \frac{\delta_h}{L} \right], \quad (3.175)$$

where, by hypothesis,  $p$  and  $\frac{\langle v_x \rangle}{i\omega}$  are real quantities.

It must be noted that the factor  $\left[ (1-i) \frac{\delta_h}{L} \right]$  is associated with the factor  $\left[ \lambda \frac{\partial^2 \tau}{\partial z^2} \right]$  of equation (3.169), meaning that it is related to the heat transfer between the fluid and the plates. In the case where no plates are considered, this factor vanishes (3.175).

At this point, it is possible to express the heat flux in the x-direction. The instantaneous heat flux (associated with the particles motion) that propagates through the unit of area per unit of time in the x-direction can be written in terms of specific particle entropy  $s$ ,

$$q = \rho_m T_m s v_x, \quad (3.176)$$

and its time average (compare with equivalent proof at the beginning of section 1.4.3.) can be written as

$$\begin{aligned} \bar{q} &= \rho_m T_m \frac{1}{2} \operatorname{Re}(s v_x^*) = \frac{1}{2} \rho_m T_m \operatorname{Re} \left[ \left( \frac{C_p}{T_m} \tau - \frac{\alpha}{\rho_m} p \right) v_x^* \right], \\ &= \frac{1}{2} \rho_m C_p \operatorname{Re}(v_x^* \tau) = \frac{1}{2} \rho_m C_p \operatorname{Im}(v_x) \operatorname{Im}(\tau), \end{aligned} \quad (3.177)$$

since  $\operatorname{Re}(p v_x^*) = 0$  because of the phase quadrature between  $p$  and  $v_x$ . This is the mean heat flux induced by acoustic process. The total energy flux between the two plates of width  $\ell$  can be written as

$$\bar{Q} = \frac{\ell}{2} \rho_m C_p \int_0^L \operatorname{Im}(v_x) \operatorname{Im}(\tau) dz.$$

By replacing  $v_x$  and  $\tau$  with their respective mean value (as previously done), one obtains

$$\bar{Q} = \frac{L\ell}{2} \rho_m C_p \operatorname{Im}(\langle v_x \rangle) \operatorname{Im}(\langle \tau \rangle), \quad (3.178)$$

where substituting the expression (3.175) for the mean value of  $\tau$ ,

$$\bar{Q} = -\frac{\ell}{2} \delta_h \alpha T_m p \operatorname{Im}(\langle v_x \rangle) (\Gamma - 1), \quad (3.179)$$

$$\text{with } \Gamma = \frac{\partial T_m / \partial x}{(\partial T_m / \partial x)_{\text{crit.}}} \text{ and } \left. \frac{\partial T_m}{\partial x} \right|_{\text{crit.}} = \frac{\alpha T_m p}{\rho_m C_p \langle v_x \rangle}, \quad (3.180)$$

(the meaning of the index *crit.* is explained below).

The substitution of the expression (3.174) of  $v_x$ , in which  $p$  and  $\frac{\partial p}{\partial x}$  are real (stationary waves) finally leads to an expression of the heat flux

$$\bar{Q} = -\frac{\ell}{2} \delta_h \alpha T_m \frac{p}{\rho_m \omega} \frac{\partial p}{\partial x} \left(1 - \frac{\delta_v}{L}\right) (\Gamma - 1), \quad (3.181)$$

where  $1 - \frac{\delta_v}{L} > 0$  and  $\frac{\partial p}{\partial x} < 0$  (by hypothesis).

For now, the sign of  $\bar{Q}$  is the same as the sign of the function  $(\Gamma - 1)$ .

If  $\Gamma - 1 > 0$ ,  $\left| \frac{\partial T_m}{\partial x} \right| > \left| \frac{\partial T_m}{\partial x} \right|_{\text{crit.}}$  and  $\bar{Q} > 0$ , then the heat flux occurs in the positive  $x$ -direction, from the “hot” zone to the “cold” zone. Equation (3.175)

$$\langle \tau \rangle \approx \frac{\langle v_x \rangle}{i\omega} \left[ \left( \frac{\partial T_m}{\partial x} \right)_{\text{crit.}} - \left( \frac{\partial T_m}{\partial x} \right) \right] \left[ 1 - (1-i) \frac{\delta_h}{L} \right] \quad (3.182)$$

shows that the temperature variation corresponding to the adiabatic motion,  $\left( \frac{\partial T_m}{\partial x} \right)_{\text{crit.}}$ , does not compensate for the variation of mean temperature  $T_m$

recorded by the particle during its displacement. The system then works as a thermo-acoustic engine: part of the energy of the heat flux between the hot source and the cold source is transformed into acoustic energy.

If  $\Gamma - 1 < 0$ ,  $\left| \frac{\partial T_m}{\partial x} \right| < \left| \frac{\partial T_m}{\partial x} \right|_{\text{crit.}}$  and  $\bar{Q} < 0$ , then the heat flux occurs in the negative  $x$ -direction, from the cold zone to the hot zone. The system works as an acoustic refrigerator (or heat pump).

The heat flux is, in particular, proportional to the thickness  $\delta_h$  of the thermal boundary layers close to the plates. It is necessary and its role is therefore important. It is proportional to the acoustic energy flux of the stationary wave represented by the function  $\frac{p}{\rho_m \omega} \frac{\partial p}{\partial x}$  (product of the particle velocity and the pressure) and is limited by the viscosity effects represented by the factor  $\left(1 - \frac{\delta_v}{L}\right)$  (obtained by assuming that  $\delta_v < L$ ).



Finding the complete solution to the problem requires the calculation of the amplitude of the pressure  $p$  using the equations that have not yet been introduced in the process (including the mass conservation law) and the associated interface conditions. This calculation is not detailed here. However, the acoustic energies involved are calculated below to complete the discussion on the functioning of a refrigerator or engine, particularly by calculating their efficiency and output.

After one cycle of heat transfer between the fluid and the plates, the work received by a particle of fluid results from the variation of total pressure  $P$  and specific volume  $V$  that occurs due to the heat transfers. In other words, the elementary work received by a particle and considered here per unit of volume can be written as

$$dW = \rho \left[ -Pd\left(\frac{1}{\rho}\right) \right] = \frac{P}{\rho} dp. \quad (3.183)$$

It is worth noting that the processes followed in section 1.4.2 are not applicable here since they assumed the fluid to be non-dissipative and the mean gradient of temperature was not considered. Moreover, they can only be applied on the acoustic energy involved within the limitation of linear acoustics.

The instantaneous power per unit of volume received by the fluid can be written as follows

$$\frac{dW}{dt} = \frac{P}{\rho} \frac{dp}{dt} = \frac{P}{\rho} \left( \frac{\partial p}{\partial t} + v_x \frac{\partial p}{\partial x} \right) \approx \frac{P}{\rho} \left( \frac{\partial p}{\partial t} + \langle v_x \rangle \frac{\partial p}{\partial x} \right), \quad (3.184)$$

thus, to the first order of the infinitesimal quantities and considering that the mean density  $\rho_m$  is (by hypothesis) slowly varying with time,

$$\begin{aligned} \frac{dW}{dt} &= \frac{P_m + p}{\rho_m + \rho'} \left[ \frac{\partial \rho'}{\partial t} + \langle v_x \rangle \frac{\partial \rho_m}{\partial x} \right], \\ &\approx \frac{1}{\rho_m} \left[ P_m \left( 1 - \frac{\rho'}{\rho_m} \right) + p \right] \left[ \frac{\partial \rho'}{\partial t} + \langle v_x \rangle \frac{\partial \rho_m}{\partial x} \right]. \end{aligned} \quad (3.185)$$

Equation (1.23) of the density  $\rho'$ , namely  $\rho' = \rho_m \chi_T [p - \hat{\beta} \tau]$ , is substituted into equation (3.185). The time averaged of the resulting expression cancels out all the terms but one. Indeed, by denoting  $\bar{f} = \frac{1}{T} \int_0^T f dt$  where  $T$  is the period, one obtains:

$$-\overline{\frac{\partial \rho'}{\partial t}} = 0, \quad \overline{\langle v_x \rangle} = 0, \quad \overline{p \langle v_x \rangle} = 0 \text{ since } p \text{ and } \langle v_x \rangle \text{ are in quadrature;}$$

–  $\overline{\rho' \frac{\partial \rho'}{\partial t}} = 0$  and  $\overline{p \frac{\partial p}{\partial t}} = 0$  since the two quantities involved in each relation are in quadrature:

$$\text{and } \operatorname{Re} \left( \frac{\langle v_x \rangle \langle v_x \rangle^*}{i\omega} \right) = -\frac{1}{\omega} \operatorname{Im}(\langle v_x \rangle \langle v_x \rangle^*) = 0.$$

Consequently, the time average  $\overline{dW/dt}$  of equation (3.185), mean power per unit of volume received by the fluid, can be written as

$$\overline{\frac{dW}{dt}} = -\chi_T \hat{\beta} \overline{p \frac{\partial \tau}{\partial t}} = -\frac{1}{2} \omega \alpha \operatorname{Re}(ip\tau) = -\frac{1}{2} \omega \alpha p \operatorname{Im}(\tau), \quad (3.186)$$

and the total mean power received by the fluid between the two plates of length  $\Delta x$ ,

$$\overline{p} = \ell \Delta x \int_0^L \overline{\frac{dW}{dt}} dz$$

can be written as

$$\begin{aligned} \overline{p} &= -\frac{\ell \Delta x}{2} \omega \alpha p L \operatorname{Im}(\langle \tau \rangle), \\ &= -\frac{1}{2} \ell \Delta x \omega \alpha p \left[ \frac{\alpha T_m}{C_p \rho_m} p - \frac{\partial T_m}{\partial x} \frac{\langle v_x \rangle}{i\omega} \right] \delta_h, \\ &= -\frac{1}{2} \ell \Delta x \delta_h \frac{\alpha^2 T_m \omega}{\rho_m C_p} p^2 (\Gamma - 1). \end{aligned} \quad (3.187)$$

The mean total acoustic power received by the fluid is of the same sign as the factor  $(\Gamma - 1)$ . Therefore:

– if  $(\Gamma - 1) > 0$ , the system works as a thermo-acoustic engine, like a loudspeaker. Part of the heat that flows from the hot source  $T_+$  to the cold source  $T_-$  is transformed into acoustic energy;

– if  $(\Gamma - 1) < 0$ , the system works as a refrigerator (or a heat pump).

These conclusions are in accordance with those previously stated following the expression of the heat flux  $\overline{Q}$  (3.181).

According to equation (3.169b), the factor  $\frac{\alpha T_m}{\rho_m C_P}$  is proportional to  $(\gamma - 1)$ , a quantity that measures the difference between isothermal compressibility and adiabatic compressibility. One analysis of these results shows that setting this factor to be as large as possible is of interest. This observation motivates the use of helium ( $\gamma = 1.65$ ) in some systems.

One can approximate the output  $\eta$  of the engine by considering equations (3.187), (3.180), (3.181) and (3.174):

$$\eta \approx -\frac{\bar{p}}{Q} \approx \frac{\Delta x \alpha \omega^2 p}{C_P (\partial p / \partial x)} = \frac{\rho_m \Delta x \omega < v_x >}{i T_m (\partial p / \partial x)} \left( \frac{\partial T_m}{\partial x} \right)_{\text{crit.}},$$

$$\text{thus } \eta \approx \frac{\Delta x}{T_m} \left( \frac{\partial T_m}{\partial x} \right)_{\text{crit.}} = \frac{(\partial T_m / \partial x) \Delta x}{T_m \Gamma} \approx \frac{\Delta T_m}{T_m} \frac{1}{\Gamma} \approx \frac{\eta_c}{\Gamma}, \quad (3.188)$$

where  $\eta_c$  denotes the classic Carnot efficiency (theoretical maximum efficiency). Therefore, as a first approximation, the output of a thermo-acoustic engine is the product of the factor  $\frac{1}{\Gamma} < 1$  by the theoretical Carnot efficiency. These systems, engine or heat pump, appear in industrial systems.

### 3.11. Introduction to acoustic gyrometry (on the use of the phenomena occurring in viscous boundary layers)

The gyrometer is a device that measures angular rates with respect to an inertial frame, the primary use of which is inertial navigation (maritime and air). The acoustic gyrometer is a gas-filled cavity (Figure 3.12) with a resonant acoustic field (generated by a loudspeaker) that induces (by Coriolis effect due to the assumed constant rotational velocity) another resonant acoustic field (detected by a microphone). Dissipation in the cavity is of great importance as it defines the quality factor of each of the resonances. Thus, thermal conduction and viscosity (mainly shear viscosity) are among the key parameters of the device. Shear viscosity, in particular, plays an important role as it is the cause of the conversion of part of the acoustic energy into vortical motion in the thin boundary layers of the cavity. This motion, in permanent regime, is the only motion responsible for the acoustic pressure of inertial origin (by Coriolis effect).

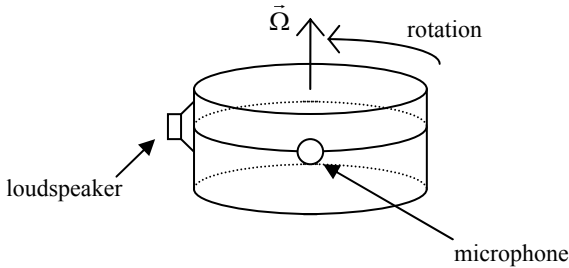

**Figure 3.12.** *Simplified representation of a classical, cylindrical acoustic gyrometer*

The principle of acoustic gyrometry is based on the fact that, in the frequency domain, under the action of a constant angular velocity  $\vec{\Omega}$ , a Coriolis acceleration ( $\vec{\gamma}_C$ ) is induced when a particle is animated by a constant velocity ( $\vec{v}$ ) relative to the system in rotation ( $\vec{\gamma}_C = 2\vec{\Omega} \wedge \vec{v}$ ). This vectorial product appears in the fundamental equation of dynamics (here it is the Navier-Stokes equation written in the inertial reference frame); the acceleration is then expressed as a function of the quantities “seen” by the observer standing in the spinning system associated to the gyrometer itself. The acoustic particle motion  $\vec{v}$  can then be the origin of this Coriolis effect. However, the acceleration of Coriolis can only trigger an acoustic perturbation if it presents a non-null divergence since it appears in the equation of propagation for the acoustic pressure as

$$\Leftrightarrow p = -\text{div } \vec{f}_C. \quad (3.189)$$

The divergence term is nothing more than the divergence of the Coriolis force ( $\vec{f}_C = \rho_0 \vec{\gamma}_C$ ). One could easily demonstrate that the other inertial factors do not contribute to the acoustic field in permanent rotation and that, consequently, the latter term is the only one to consider. This observation can be intuitively understood since  $\partial \vec{\Omega} / \partial t = \vec{0}$  (by hypothesis) and because the centrifugal acceleration only generates a positive density gradient toward the walls that remains inefficient in terms of acoustic perturbations for lower rotation rates.

Since  $\text{rot } \vec{\Omega} = \vec{0}$  by hypothesis and the particle velocity  $\vec{v}$  is the sum of two components – ( $\vec{v} = \vec{v}_\ell + \vec{v}_v$ ) with the former ( $\vec{v}_\ell$ ) being irrotational (since it is laminar) whereas the latter is not (vortical motion), the inertial effects are consequently expressed by a factor defined by

$$\text{div} (2\vec{\Omega} \wedge \vec{v}) = 2[\vec{v} \cdot \text{rot } \vec{\Omega} - \vec{\Omega} \cdot \text{rot } \vec{v}] = -2 \vec{\Omega} \cdot \text{rot } \vec{v} = -2 \vec{\Omega} \cdot \text{rot } \vec{v}_v. \quad (3.190)$$

Thus, for an acoustic field in a cavity, only the vortical component of the particle velocity (that is triggered within the viscous boundary layers) contributes to the source term

$$\operatorname{div}(\vec{f}_c) = -2\rho_0\vec{\Omega}\cdot\operatorname{rot}\vec{v}_v. \tag{3.191}$$

Consequently, this “source” of Coriolis, which is induced by the background acoustic field (vector  $\vec{v}$  in  $\vec{\Omega} \wedge \vec{v}$ ), is localized on the walls of the cavity. Finally, a primary resonant acoustic field is generated by the loudspeaker within the closed cavity while a second resonant acoustic field is generated by Coriolis effect. By energy transfer between two resonance fields, a modal coupling occurs which is maintained by Coriolis effect on the vortical motion within the boundary layers.

In practice, both the primary and secondary acoustic fields are resonant, and sensitivity of the device is improved accordingly. Then the sensitivity of some gyrometers can reach  $10^{-2}$  °/s and their dynamic range can be  $10^7$  with an excellent linear response.

Solving the problem completely requires the use of integral equations and their estimation by using the modal theory (method presented in the Chapter 9). In this section, the aim is to describe the phenomenon by finding the expression of  $\operatorname{div} \vec{f}_c$ .

The considered phenomenon occurs significantly only at the immediate vicinity of the walls of the cavity, within the viscous boundary layers. One only needs to solve the problem at these points. The notations used for the local coordinates are presented in Figure 3.13, the axis  $\vec{u}$  being directed outward of the cavity.

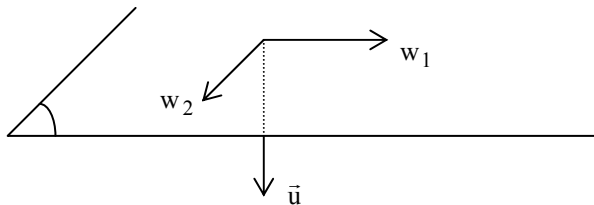

**Figure 3.13.** Local coordinates used at the vicinity of the walls of the gyrometer ( $\vec{u}$  is a unit vector, normal to the wall, outward the cavity)

By assuming the following approximations:

$$\begin{aligned}
 p_a &\approx \frac{\gamma \hat{\beta}}{\gamma - 1} \tau_a, \text{ (equation (2.82a))} \\
 \left| k_0 \ell_h \frac{\partial}{\partial u} \hat{\tau}_h(k_{hu} u) \right| &\ll \left| \frac{\partial}{\partial u} \hat{\tau}_a(k_{au} u) \right|, \\
 \left| k_0 \ell_h \hat{\tau}_h(k_{hu} u) \right| &\ll \left| \hat{\tau}_a(k_{au} u) \right|, \\
 k_v^2 &= k_{vu}^2 + k_{aw_1}^2 + k_{aw_2}^2 \approx k_v^2 \text{ (see equations (2.85) and (2.112)),}
 \end{aligned} \tag{3.192}$$

and writing

$$p_a(u, w_1, w_2) = \hat{p}_a(k_{au} u) \psi(k_{aw_1} w_1, k_{aw_2} w_2),$$

the boundary conditions (2.107) and (2.108) can be written as

$$\begin{aligned}
 v_{vu} &\approx \frac{-i}{k_0 \rho_0 c_0} \frac{\partial}{\partial u} \hat{p}_a(u=0) \psi(k_{aw_1} w_1, k_{aw_2} w_2) e^{ik_v u}, \\
 v_{vw_1} &\approx \frac{-i}{k_0 \rho_0 c_0} \hat{p}_a(u=0) \frac{\partial}{\partial w_1} \psi(k_{aw_1} w_1, k_{aw_2} w_2) e^{ik_v u}, \\
 v_{vw_2} &\approx \frac{-i}{k_0 \rho_0 c_0} \hat{p}_a(u=0) \frac{\partial}{\partial w_2} \psi(k_{aw_1} w_1, k_{aw_2} w_2) e^{ik_v u},
 \end{aligned} \tag{3.193}$$

where the solution along the axis  $\bar{u}$  has been chosen as a diffusion process and is a solution to equation (2.80).

One can obtain, after all calculations have been done, the three components of the vortical velocity  $\bar{v}_v$ :

$$\begin{aligned}
 (\bar{r} \bar{ot} \bar{v}_v)_u &= 0, \\
 (\bar{r} \bar{ot} \bar{v}_v)_{w_1} &= -\frac{k_v}{\rho_0 \omega} e^{+ik_v u} \frac{\partial}{\partial w_2} p_a(0, w_1, w_2),
 \end{aligned} \tag{3.194}$$

$$\begin{aligned}
 (\bar{r} \bar{ot} \bar{v}_v)_{w_2} &= -\frac{k_v}{\rho_0 \omega} e^{+ik_v u} \frac{\partial}{\partial w_1} p_a(0, w_1, w_2), \\
 \text{thus } \bar{r} \bar{ot} \bar{v}_v &= +\frac{k_v}{\rho_0 \omega} e^{+ik_v u} \left[ \bar{u} \wedge \bar{\nabla}_{\bar{w}} p_a(0, w_1, w_2) \right],
 \end{aligned} \tag{3.195}$$

where  $\bar{u}$  denotes the unit vector, directed outward of the cavity and normal to its wall, and  $\bar{\nabla}_{\bar{w}}$  is the gradient in the plane tangent to the wall.

The acoustic source associated with the Coriolis effect is therefore described by the following function (which appears in the right-hand side term of the equation of propagation):

$$\operatorname{div}(\vec{f}_c) = -2 \frac{k_v}{\omega} e^{+ik_v u} \vec{\Omega} \cdot [\vec{u} \wedge \vec{\nabla}_{\vec{w}} p_a(0, w_1, w_2)], \tag{3.196}$$

where  $p_a(0, w_1, w_2)$  denotes the acoustic field generated by the loudspeaker (as a first approximation, called Born’s approximation) and where the rapid decrease of the factor  $e^{+ik_v u}$  reveals that the “secondary source” induced by the Coriolis effect occurs only at the vicinity of the wall (within the viscous boundary layers).

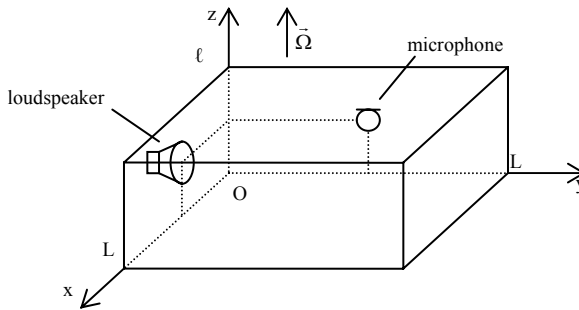

**Figure 3.14.** Gyrometric cavity with a square base  $(x,y)$ : the loudspeaker is located at the center of the  $(Ox,Oz)$  face, the microphone at the center of the  $(Oy,Oz)$  face and the rotation vector  $\vec{\Omega}$  is collinear with the  $\vec{Oz}$ -axis

By way of example, let a gyrometric cavity with a square base (Figure 3.14) contain an acoustic pressure field  $p_a$ , generated by a loudspeaker located at the center of the  $(Ox, Oz)$  face, in the form of a resonant mode  $\cos(\pi y / L)$ . Also, the factor  $\vec{\nabla}_{\vec{w}} p_a = \vec{\nabla}_y p_a$  is assumed along the  $\vec{Oy}$ -axis. The other resonant mode (along the  $x$ -axis) is not generated since the loudspeaker is located at its node. The unit vector  $\vec{u}$  of equation (3.196) being normal to the considered face, only the faces that are perpendicular to the  $\vec{Ox}$ -axis present a non-null factor  $\vec{\Omega} \cdot [\vec{u} \wedge \vec{\nabla}_y p_a]$  for an angular velocity  $\vec{\Omega}$  that is collinear with the  $\vec{Oz}$ -axis.

Therefore, the sources described by the factor  $\operatorname{div} \vec{f}_c$  exist only on the two faces that are perpendicular to the  $\vec{Ox}$ -axis and are out of phase. Their amplitude, in terms of  $\partial p_a / \partial y \sim \sin(\pi y / L)$ , are in phase at any given point on each face and present a symmetry with respect to the axis  $y = L/2$  of each face. Therefore, the resonant mode  $\cos(\pi x / L)$  is generated and detected by the microphone that, located at the center of the  $(Oy, Oz)$  face, coincides with a node of the mode

generated by the loudspeaker and can only measure the Coriolis mode. Moreover, since this mode only exists in presence of the primary field  $p_a$ , the process is an energy transfer from the primary mode  $\cos(\pi y/L)$  to the Coriolis mode  $\cos(\pi x/L)$ , in other words a coupling. The analytical expression of this coupling is given in section 9.2.4.1.2 (equations (9.36) to (9.39)).



*This page intentionally left blank*

## Chapter 4

# Basic Solutions to the Equations of Linear Propagation in Cartesian Coordinates

### 4.1. Introduction

The objective of this chapter and the following ones (with the exception of Chapters 10 and 11) is to introduce the methods used to solve the fundamental equations of linear acoustics in dissipative and homogeneous fluids, and the solutions for the acoustic motion that are most widely used in solving acoustic problems. The term “acoustic motion” implies that the entropic and vortical variables are not among those considered here. However, this does not mean that dissipation is ignored completely as it plays an important and fundamental role in practice (for many reasons detailed in this chapter) and simplifies, to some extent, the modeling process.

The bivariance of the medium (first hypothesis) implies the use of only two independent variables to describe the thermodynamic state of the fluid in motion. However, to limit the problem to two scalar variables among the many involved (pressure, density, temperature, entropy, etc.) would be to overlook the vectorial nature of an acoustic field: the particle velocity. The knowledge of this vectorial quantity leads directly to the knowledge of one of the scalar quantity (i.e. the density variation  $\rho'$  via the mass conservation law) so that one can substitute the scalar quantity for the particle velocity. Moreover, the “pressure variation” plays a major and unique role in acoustic problems simply because most acoustic sensors are only sensitive to this quantity. It is therefore clear that the most convenient couple of variables to represent an acoustic field are the pressure variation and the particle

velocity. Also, for the sake of simplicity, most equations of propagation and boundary conditions will be expressed in terms of those variables.

Since the entropic pressure is much less than the acoustic pressure, especially outside the viscous and thermal boundary layers, it will systematically be ignored. The pressure variation will consequently be identified with the acoustic pressure  $p_a$  and be denoted  $p$ . Similarly, since outside the viscous and thermal boundary layers the entropic and vortical velocities are negligible, the acoustic particle velocity  $\bar{v}_a$  is identified with the particle velocity  $\bar{v}$ . This approximation implies that the phenomena occurring within the boundary layers, where the acoustic particle velocities are of similar magnitude to the sum of the two other forms of particle velocity, are not considered. The concept of “equivalent” acoustic impedance (presented in section 3.2, equation (3.10)) comes in useful; at the vicinity of the rigid walls, the admittance expressing the boundary conditions is not null (partial reflection), but equal to  $1/Z_a$ . This facilitates the treatment of the boundary layers’ effects on the reflection of acoustic waves in dissipative fluids (in Fourier domain of course). It is, however, useful to remind the reader that this impedance presents the particular characteristics that it depends on  $(1 - k_{a\perp}^2/k_a^2)$  where  $k_a$  denotes the wavenumber associated with the acoustic propagation and  $k_{a\perp}$ , its projection onto the direction normal to the tangent plane at the boundary. The impedance subsequently depends on the angle of incidence of the wave. Therefore, one needs to pay particular attention when estimating this factor at the vicinity of the walls.

In accordance with the previous statements, it is often enough to consider the problem within the approximation of linear acoustics, in homogeneous and dissipative fluids at rest (including initial and boundary conditions), beginning with the system of equations governing the acoustic pressure ( $p \sim p_a$ ); the particle velocity can be deduced using the simple and linear Euler’s equation. Therefore, the fundamental equation of acoustic propagation in a dissipative fluid, in the conditions given above, can be written as (equations (2.76) and (1.61))

$$\left[ \frac{1}{c_0^{*2}} \frac{\partial^2}{\partial t^2} - (1 + \ell_{\text{vh}} \frac{1}{c_0} \frac{\partial}{\partial t}) \Delta \right] p(\bar{r}, t) \approx -\rho_0 \left[ \text{div} \bar{F} - \frac{\partial q}{\partial t} - \frac{\alpha}{C_p} \frac{\partial h}{\partial t} \right], \quad (4.1)$$

with, if a relaxation process is to be considered (equation (2.58)),

$$\frac{1}{c_0^{*2}} = \frac{\rho_0 \chi_T}{\gamma} \frac{\gamma}{\gamma^*} = \frac{1}{c_0^2} \left[ 1 - D_{\text{v}\theta} \frac{\partial}{\partial t} \left( 1 + \theta \frac{\partial}{\partial t} \right)^{-1} \right], \quad (4.2)$$

where  $D_v = (\gamma - 1) C_v^{(v)} / C_p$  in the relaxation case considered in section 2.4.3. This operator would generally be written as

$$\frac{1}{c_0^{*2}} = \frac{1}{c_0^2} \left[ 1 - D_v \frac{\partial}{\partial t} \int_{-\infty}^t dt' e^{-(t'-t)/\theta} \right]. \tag{4.3}$$

This equation in the time domain presents all the characteristics of an equation that does not have an analytical solution; moreover, it is pointless to express the boundary conditions in the time domain as the condition associated to a non-null admittance introduces a convolution product in this domain (equation (1.75)). Therefore, whenever possible (null initial conditions), problems are treated in the Fourier domain. The only problems solved here in the time domain are those where dissipation is ignored.

In the Fourier domain, equation (4.1) becomes

$$\begin{aligned} \left[ (1 + ik_0 \ell_{vh}) \Delta + k_0^2 \left( 1 - \sum_v D_v \frac{i\omega\theta_v}{1 + i\omega\theta_v} \right) \right] p(\vec{r}) \\ = \rho_0 \left( \text{div} \vec{F} - i\omega q - i\omega \frac{\alpha}{C_p} h \right), \end{aligned} \tag{4.4}$$

where the same notations are used for the functions  $p$ ,  $F$ ,  $q$ , and  $h$ , and their Fourier transforms, and where the sum indicates that if several relaxation processes are to be considered, they would also appear in the equation as a sum.

Equation (4.4) can also be written, ignoring the factor  $(-ik_0 \ell_{vh})$  in the second term (which in practice does not affect in any way the source functions), as

$$\left[ \Delta + k_0^2 \left( 1 - ik_0 \ell_{vh} - \sum_v D_v \frac{i\omega\theta_v}{1 + i\omega\theta_v} \right) \right] p = \rho_0 \left( \text{div} \vec{F} - i\omega q - i\omega \frac{\alpha}{C_p} h \right). \tag{4.5}$$

Equation (4.5) will be written in the following form (Helmholtz equation):

$$(\Delta + k^2) p = \rho_0 \left( \text{div} \vec{F} - i\omega q - i\omega \frac{\alpha}{C_p} h \right), \tag{4.6}$$

with

$$k^2 = k_0^2 \left( 1 - ik_0 \ell_{vh} - \sum_v D_v \frac{i\omega\theta_v}{1+i\omega\theta_v} \right), \quad (4.7a)$$

$$k^2 \approx k_0^2 \left[ 1 - \sum_v D_v \frac{\omega^2\theta_v^2}{1+\omega^2\theta_v^2} - i \left( k_0 \ell_{vh} + \sum_v D_v \frac{\omega\theta_v}{1+\omega^2\theta_v^2} \right) \right], \quad (4.7b)$$

where  $k_0 = \omega/c_0$ ,  $\omega$  being the angular frequency of the source and  $c_0$  the adiabatic speed of sound in the considered medium.

Writing the complex wavenumber as

$$k = \frac{\omega}{c_a} - i\Gamma,$$

one can deduce the wave speed

$$c_a \approx c_0 \left( 1 + \frac{1}{2} \sum_v D_v \frac{\omega^2\theta_v^2}{1+\omega^2\theta_v^2} \right) \approx c_0, \quad (4.8)$$

and the attenuation factor

$$\Gamma \approx \frac{k_0}{2} \left( k_0 \ell_{vh} + \sum_v D_v \frac{\omega\theta_v}{1+\omega^2\theta_v^2} \right), \quad (4.9)$$

or, in the absence of molecular relaxation,

$$c_a = c_0 \text{ and}$$

$$\Gamma = \frac{1}{2} k_0^2 \ell_{vh} \text{ (attenuation factor called "classical attenuation")}. \quad (4.10)$$

A generalized complex speed of sound can be defined as

$$c \approx c_0 \left[ 1 + \frac{1}{2} \sum_v D_v \frac{\omega^2\theta_v^2}{1+\omega^2\theta_v^2} + \frac{i}{2} \left( k_0 \ell_{vh} + \sum_v D_v \frac{\omega\theta_v}{1+\omega^2\theta_v^2} \right) \right], \quad (4.11)$$

with  $k = \omega/c$ ,

or, in the absence of any molecular relaxation,

$$c = c_0 \left[ 1 + \frac{i}{2} k_0 \ell_{vh} \right]. \quad (4.12)$$

The real part of the expression of the speed of sound (as shown above) represents the “true” speed of sound while the imaginary part represents the attenuation factor.

Note: the objective of this chapter (where the problems are solved in a Cartesian coordinate system) and of the following one (where the problems are solved in a cylindrical coordinate system) is to present the forms of the basic solutions to the wave equation associated with typical fundamental problems. These problems are treated outside the action of sources for the sake of simplicity, but also because considering the coupling between acoustic fields and source functions requires (most of the time) the use of the integral formalism at the limits of linear acoustics. This formalism is not discussed until Chapter 6.

## 4.2. General solutions to the wave equation

### 4.2.1. Solutions for propagative waves

Outside the action of any source, the wave equation in Cartesian coordinates for a dissipative fluid is given by

$$\left( \frac{\partial^2}{\partial x^2} + \frac{\partial^2}{\partial y^2} + \frac{\partial^2}{\partial z^2} \right) p(\vec{r}, t) = \frac{1}{c^2} \frac{\partial^2}{\partial t^2} p(\vec{r}, t), \quad (4.13a)$$

where the factor  $c^2$  is given by equation (4.1) and defined by

$$c^2 = c_0^2 \left[ 1 + \ell_{vh} \frac{1}{c_0} \frac{\partial}{\partial t} \right]. \quad (4.13b)$$

If the molecular relaxation is considered, the term  $c_0$  shall be replaced by  $c_0^*$  (equation (4.2)).

If one ignores the dissipation processes,  $c = c_0$  and any function of the dimensionless argument  $\left[ \omega \left( t \pm \frac{\vec{n} \cdot \vec{r}}{c_0} \right) \right] = [\omega t \pm \vec{k}_0 \cdot \vec{r}]$  (where  $\omega$  and  $k_0$  are quantities of dimensions  $s^{-1}$  and  $m^{-1}$ , respectively) is solution to equations (4.13) on the condition that the following dispersion relation is satisfied:

$$k_0^2 = k_x^2 + k_y^2 + k_z^2 = \frac{\omega^2}{c_0^2}. \quad (4.14)$$

Thus, considering the negative sign in the argument  $(\omega t - \vec{k}_0 \cdot \vec{r})$ , this form of solution represents a wave propagating in the same direction as  $\vec{k}_0$  with a propagation speed given by the ratio of the distance traveled by a point of the wave  $\frac{\vec{k}_0}{|\vec{k}_0|} \cdot d\vec{r}$  to the time  $dt$  requires to travel this distance. These two quantities are related by the relation  $|\vec{k}_0 \cdot d\vec{r}| = \omega dt$  (constant phase). The wave speed is therefore

$$c_0 = \frac{\vec{k}_0}{|\vec{k}_0|} \cdot \frac{d\vec{r}}{dt} = \frac{\omega}{k_0}. \tag{4.15}$$

The plane harmonic wave solution to equation (4.13a),

$$A e^{-i\vec{k} \cdot \vec{r}} e^{i\omega t} \tag{4.16}$$

$A$  being a constant, presents the advantage that when  $k$  is real ( $k = k_0$ ), it constitutes a continuous basis of eigenfunctions of the considered operator  $\square = \Delta - \frac{1}{c_0^2} \frac{\partial^2}{\partial t^2} = \frac{\partial^2}{\partial x^2} + \frac{\partial^2}{\partial y^2} + \frac{\partial^2}{\partial z^2} - \frac{1}{c_0^2} \frac{\partial^2}{\partial t^2}$ , in which any solution can be uniquely expanded as

$$p(\vec{r}, t) = \frac{1}{(2\pi)^3} \iint \int_{-\infty}^{\infty} d^3\vec{k}_0 e^{-i\vec{k}_0 \cdot \vec{r}} \frac{1}{2\pi} \int_{-\infty}^{\infty} d\omega e^{i\omega t} p(\vec{k}_0, \omega). \tag{4.17}$$

These expansions can be partial, such as

$$p(\vec{r}, t) = \frac{1}{(2\pi)^2} \int_{-\infty}^{\infty} dk_{0x} \int_{-\infty}^{\infty} dk_{0y} e^{-i(k_{0x}x + k_{0y}y)} \frac{1}{2\pi} \int_{-\infty}^{\infty} d\omega e^{i\omega t} p(k_{0x}, k_{0y}, z, \omega). \tag{4.18a}$$

The factor  $1/(2\pi)^4$  in equation (4.17) normalizes the basis of eigenfunctions since

$$\frac{1}{2\pi} \int_{-\infty}^{\infty} e^{i\omega t} e^{-i\omega' t} dt = \delta(\omega - \omega') \tag{4.18b}$$

(and so on for all integrals).

The surface of equal phase associated with the wave represented by the function  $Ae^{\pm i\vec{k}\cdot\vec{r}} e^{i\omega t}$  are planes perpendicular to the  $\vec{k}$ -axis and propagating in the positive  $r$ -direction, respectively in the negative  $r$ -direction, according to whether the sign in the exponential is “+” or “-”. The phase velocity is then equal to  $\omega/\text{Re}(k)$ . If one of the axes (the  $x$ -axis for example) is chosen so that it coincides with the direction of propagation  $\vec{k}$ , the plane wave solution can be written simply (note the exponential decreases) as

$$A e^{\pm ikx} e^{i\omega t} = A e^{\mp \text{Im}(k)x} e^{\pm i \text{Re}(k)x} e^{i\omega t} . \tag{4.19}$$

This result can be applied to a very practical case. At the entrance of a cylindrical tube along the  $x$ -axis, a loudspeaker generates a system of harmonic plane waves that are reflected at the other end of the tube ( $x = L$ ). The description of the energy transfer from the loudspeaker to the column of gas and the conditions fulfilled for the conservation of the plane geometry of the waves are detailed latter in this book. One only needs to assume that a plane wave is propagating all the way to the end of the tube, is then reflected and travels all the way back with an attenuated amplitude. It is then reflected (and therefore attenuated) again and so on. Considering the situation at a given time  $t$  (the loudspeaker is emitting since the time  $t_i \rightarrow -\infty$ ) and at a given point  $x \in [0, L]$ , the pressure field is the sum of:

- the direct wave (from the loudspeaker)  $a_0 \exp[-ikx]$  (the time factor is omitted);
- the first reflected wave (1st reflection at  $x = L$ ) propagating in the negative  $x$ -direction, that has traveled the distance  $(2L - x)$ ,  $R_L a_0 \exp[ik(x - 2L)]$  where  $R_L$  denotes the amplitude reflection coefficient at  $x = L$ ;
- the second reflected wave (1st reflection at  $x = 0$ ) propagating in the positive  $x$ -direction, that has traveled the distance  $(2L + x)$ ,  $R_0 R_L a_0 \exp[- ik(x + 2L)]$  where  $R_0$  denotes the amplitude reflection coefficient at  $x = 0$ ;
- etc.

Finally, the pressure field at the abscissa  $x$  and at the time  $t$  results from the superposition of an infinite number of waves propagating in the positive  $x$ -direction

$$a_0 \left[ e^{-ikx} + R_0 R_L e^{-ik(x+2L)} + \dots + (R_0 R_L)^n e^{-ik(x+2nL)} + \dots \right] e^{i\omega t} , \tag{4.20a}$$

and of an infinite number of waves propagating in the negative  $x$ -direction

$$R_L a_0 \left[ e^{ik(x-2L)} + R_0 R_L e^{ik(x-4L)} + \dots + (R_0 R_L)^n e^{ik(x-2L-2nL)} + \dots \right] e^{i\omega t} . \tag{4.20b}$$



Equation (4.20a) and (4.20b) give, respectively:

$$a_0 e^{-ikx} \left[ 1 + R_0 R_L e^{-2ikL} + \dots + (R_0 R_L)^n e^{-ik2nL} + \dots \right] e^{i\omega t} = B a_0 e^{-ikx} e^{i\omega t},$$

and:

$$\begin{aligned} R_L a_0 e^{ik(x-2L)} \left[ 1 + R_0 R_L e^{-2ikL} + \dots + (R_0 R_L)^n e^{-ik2nL} + \dots \right] e^{i\omega t} \\ = B R_L a_0 e^{-2ikL} e^{ikx} e^{i\omega t}, \end{aligned}$$

where the geometric series B is equal to

$$\frac{1}{1 - R_0 R_L e^{-2ikL}}. \quad (4.21)$$

The pressure field can then be written as

$$\begin{aligned} p(x, t) &= B a_0 \left[ e^{-ikx} + R_L e^{-2ikL} e^{ikx} \right] e^{i\omega t}, \\ &= B a_0 e^{-ikL} \left[ e^{ik(L-x)} + R_L e^{-ik(L-x)} \right] e^{i\omega t}, \end{aligned} \quad (4.22)$$

showing that the field can be represented as two plane waves (one traveling toward the extremity  $x = L$ , the other one traveling toward the extremity  $x = 0$ ).

In the particular case where the reflection coefficient  $R_L$  is equal to one, equation (4.22) becomes

$$p(x, t) = 2B a_0 e^{-ikL} \cos[k(L-x)] e^{i\omega t}. \quad (4.23)$$

This solution is called “stationary” since the real associated function is the product of a function of the variable  $x$  by a sinusoidal function of the variable  $t$ .

Note: in the argument  $\omega t \pm \vec{k} \cdot \vec{r}$  of the solutions, the chosen sign in front of the factor  $\omega t$  is the positive sign rather than the negative one. This is an arbitrary choice. The factor  $\exp(+i\omega t)$  used here is the one in accordance with the usual definition of the Fourier transform.

#### 4.2.2. Solutions with separable variables

When the spatial domain considered is not infinite in all directions (closed space or space closed in some directions only) the progressive wave solution presented in

the previous paragraph is still a solution to the problem, but is not well suited to the calculation and interpretation of the phenomena. It is generally more appropriate to look for a solution with separated variables of the form:

$$p = X(x)Y(y)Z(z)T(t). \tag{4.24}$$

The wave equation, away from any source, can then be written (dividing each term by the solution  $p$  of equation 4.24) as

$$\frac{1}{X} \frac{\partial^2 X}{\partial x^2} + \frac{1}{Y} \frac{\partial^2 Y}{\partial y^2} + \frac{1}{Z} \frac{\partial^2 Z}{\partial z^2} = \frac{1}{T} \frac{1}{c^2} \frac{\partial^2 T}{\partial t^2}. \tag{4.25}$$

For a time-dependent function to be equal to a function depending on field variables  $\forall(x, y, z, t)$  in the domain considered, each side of equation (4.25) must be equal to the same constant denoted here  $(-k^2)$ . Thus, when writing  $k^2 c^2 = \omega^2$ , one obtains:

$$\frac{\partial^2 T}{\partial t^2} + \omega^2 T = 0, \quad \forall t. \tag{4.26}$$

The solution to equation (4.26) can be written either as  $\sin(\omega t + \varphi_{1t})$  or as  $\cos(\omega t + \varphi_{2t})$  where  $\varphi_{1t}$  and  $\varphi_{2t}$  are phases depending on the initial time considered. Thus, in the complex domain, the solution can be written as  $\exp[i(\omega t + \varphi_{+t})]$  or  $\exp[-i(\omega t + \varphi_{-t})]$ . The functions  $\sin(\xi)$  and  $\cos(\xi)$ , as the functions  $\exp(i\xi)$  and  $\exp(-i\xi)$ , constitute a basis of eigenfunctions of the operator  $\partial^2 / \partial t^2$  to which corresponds a continuous spectrum of  $\omega$  values. The solution to equation (4.26) being known, equation (4.25) becomes

$$\frac{1}{X} \frac{\partial^2 X}{\partial x^2} = -\frac{1}{Y} \frac{\partial^2 Y}{\partial y^2} - \frac{1}{Z} \frac{\partial^2 Z}{\partial z^2} - k^2 = -k_x^2. \tag{4.27}$$

The application of a similar approach to equation (4.27) leads one to write that a function of  $x$  alone cannot be equal to a function of the couple  $(y, z)$  (for any value taken by these three variables) unless these two functions are equal to an arbitrary constant, noted here  $(-k_x^2)$ . Thus

$$\frac{\partial^2 X}{\partial x^2} + k_x^2 X = 0, \quad \forall x. \tag{4.28}$$

By iterative manipulation, one obtains

$$\frac{\partial^2 Y}{\partial y^2} + k_y^2 Y = 0, \quad \forall y, \quad (4.29)$$

and finally

$$\frac{\partial^2 Z}{\partial z^2} + k_z^2 Z = 0, \quad \forall z, \quad (4.30)$$

where the factor  $k_z^2$  is not arbitrarily chosen, but defined by the relation of dispersion:

$$k^2 = k_x^2 + k_y^2 + k_z^2. \quad (4.31)$$

The solutions to equations (4.28), (4.29) and (4.30) are, respectively,

$$A_1 \cos(k_i x_i) + A_2 \sin(k_i x_i), \quad \alpha_1 \cos(k_i x_i + \varphi_{1i}), \quad \alpha_2 \sin(k_i x_i + \varphi_{2i})$$

or, in the complex domain,

$$B_1 e^{ik_i x_i} + B_2 e^{-ik_i x_i}. \quad (4.32)$$

The constants  $A_i$ ,  $\alpha_i$ ,  $\varphi_{ij}$  and  $B_i$  are the couples of integration constants, “couples” since the differential equations are of the second order. Each of these solutions constitutes a basis of the considered domain and all solutions of any problem described by these types of equations can be expanded in the corresponding basis. An example is given in section 4.2.1; other examples are presented in the following section while general remarks on the matter are given in the Appendix to this chapter.

### 4.3. Reflection of acoustic waves on a locally reacting surface

#### 4.3.1. Reflection of a harmonic plane wave

A harmonic plane wave of acoustic pressure  $p_i$  is propagating, in oblique incidence, toward a ( $x = 0$ ) plane made of a locally reacting material (see section 1.3.4). The material is characterized by its acoustic impedance  $Z$  that is spatially independent (similar to the impedance  $Z_a$  associated to a rigid wall; section 3.2, equation (3.10)) and associated with a reflection coefficient  $R$ . The angle of

incidence and the angle of reflection are denoted, respectively,  $\theta$  and  $\theta'$  (Figure 4.1). The  $xOz$  plane is defined by two intersecting lines that are the direction of incidence and the  $x$ -axis.

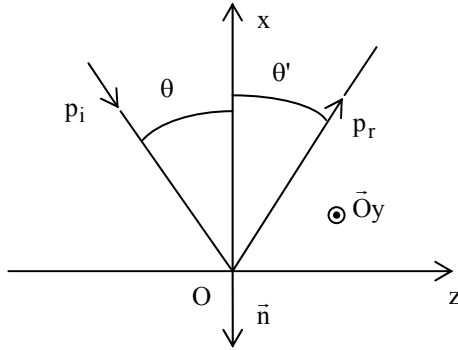

**Figure 4.1.** Reflection of a plane harmonic acoustic wave of amplitude  $p_i$  on the plane  $x = 0$  characterized by its acoustic impedance

Suppressing the time factor  $e^{i\omega t}$ , the problem can be written as

$$\left( \frac{\partial^2}{\partial x^2} + \frac{\partial^2}{\partial y^2} + \frac{\partial^2}{\partial z^2} + k^2 \right) p(x, y, z) = 0, \quad \forall x \geq 0, \quad \forall (y, z),$$

$$\frac{\partial p}{\partial x} - ik_0 \beta p = 0 \text{ at } x = 0, \quad \forall (y, z), \quad (4.33)$$

$$p_i = P_i e^{ik(x \cos \theta - z \sin \theta)},$$

where  $p_i$  denotes the complex amplitude of the incident plane wave generated by a source set at infinity, and where

$$\beta = 1/\zeta = \rho_0 c_0 / Z$$

denotes the acoustic admittance of the wall.

The solution is assumed to be the sum of the incident acoustic pressure and the reflected acoustic pressure:

$$p = p_i + p_r, \quad (4.34)$$

where

$$p_r = R P_i e^{ik(-x \cos \theta' + n_z z + n_y y)}, \quad (4.35)$$

where  $n_y$  and  $n_z$  are the projections of the normal vectors parallel to the direction of propagation of the reflected wave onto the  $y$ - and  $z$ -axes. According to the hypothesis previously made, the solution does not depend (*a priori*) on the variable  $y$ . This would lead to an incompatibility between the proposed solution and the equations it must satisfy, as shown below. The substitution of the solution into the equation of propagation leads to the following relation of dispersion:

$$\cos^2 \theta' + n_y^2 + n_z^2 = 1, \quad (4.36)$$

while the boundary condition at  $x = 0$  gives

$$\begin{aligned} P_1 i k \left[ \cos \theta e^{-ikz \sin \theta} - R \cos \theta' e^{ik(n_z z + n_y y)} \right] \\ = \frac{ik_0 \rho_0 c_0}{Z} P_1 \left[ e^{-ikz \sin \theta} + R e^{ik(n_z z + n_y y)} \right], \quad \forall (y, z). \end{aligned} \quad (4.37)$$

In the first instance, the equality of the functions of  $y$  on both sides of equation (4.37) is impossible since:

$$-R \cos \theta' e^{ik n_y y} \neq \frac{\rho_0 c_0}{Z} R e^{ik n_y y} \quad \text{as} \quad -\cos \theta' \neq \frac{\rho_0 c_0}{Z},$$

implying that  $n_y = 0$ .

Consequently, considering equation (4.36), one obtains:

$$n_z^2 = 1 - \cos^2 \theta' = \sin^2 \theta', \quad \text{or} \quad n_z = \varepsilon \sin(\theta') \quad \text{where} \quad \varepsilon = \pm 1.$$

The condition (4.37) then becomes ( $k \sim k_0$ ):

$$\frac{\cos \theta e^{-ikz \sin \theta} - R \cos \theta' e^{ik \varepsilon z \sin \theta'}}{e^{-ikz \sin \theta} + R e^{ik \varepsilon z \sin \theta'}} = \frac{\rho_0 c_0}{Z}. \quad (4.38)$$

Since the right-hand side term does not depend, by hypothesis, on the variable  $z$ , one needs to impose the following conditions:

$$\begin{aligned} -\sin(\theta) &= \varepsilon \sin(\theta'), \\ \cos(\theta) &= \cos(\theta'). \end{aligned} \quad \text{Finally, } \varepsilon = -1 \quad \text{and} \quad \theta = \theta'. \quad (4.39)$$

Consequently,

$$\zeta = \frac{Z}{\rho_0 c_0} = \frac{1}{\cos \theta} \frac{1+R}{1-R} \text{ thus } R = \frac{\zeta \cos \theta - 1}{\zeta \cos \theta + 1}. \quad (4.40)$$

The planes of incidence and reflection are the same, the angle of incidence and the angle of reflection are identical and the reflection coefficient (in terms of pressure amplitude) is related to the specific impedance  $\zeta$  by the relation (4.40). The reflected wave can then be written as

$$p_r = R P_i e^{ik(-x \cos \theta' - z \sin \theta')} \quad (4.41)$$

The component along the direction  $\bar{n}$  of the particle velocity can be obtained by using Euler's equation:

$$v_n = \frac{-i}{\rho_0 \omega} \frac{\partial p}{\partial x} = \frac{k}{\rho_0 k_0 c_0} P_i \cos \theta \left[ e^{ik(x \cos \theta - z \sin \theta)} - R e^{-ik(x \cos \theta + z \sin \theta)} \right],$$

or, since  $k$  can be different, but close to,  $k_0$  (equation (4.7)):

$$v_n \approx \frac{P_i \cos \theta}{\rho_0 c_0} \left[ e^{ik(x \cos \theta - z \sin \theta)} - R e^{-ik(x \cos \theta + z \sin \theta)} \right]. \quad (4.42)$$

The acoustic power absorbed by the material is the difference between the incident energy flux and the reflected energy flux per unit of area of the material (1.84):

$$P_a = I_i - I_r = \frac{1}{4} (p_i v_i^* + p_i^* v_i) - \frac{1}{4} (p_r v_r^* + p_r^* v_r) = \frac{P_i^2 \cos \theta}{2 \rho_0 c_0} (1 - |R|^2), \quad (4.43)$$

and the coefficient of absorption (of energy) of the material is given by

$$\alpha(\theta) = \frac{P_a}{I_i} = \frac{2 \rho_0 c_0 P_a}{P_i^2 \cos \theta} = 1 - |R|^2 = \frac{4 \operatorname{Re}(\zeta) \cos \theta}{(|\zeta| \cos \theta)^2 + 2 \operatorname{Re}(\zeta) \cos \theta + 1}. \quad (4.44)$$

The energy density of the incident wave (1.83) is

$$\begin{aligned} E_i &= \frac{1}{4} \left( \rho_0 |v_i|^2 + \frac{1}{\rho_0 c_0^2} |p_i|^2 \right), \\ &= \frac{P_i^2}{2\rho_0 c_0^2} e^{-2\text{Im}(k)[x \cos \theta - z \sin \theta]}, \quad \text{Im}(k) < 0, \end{aligned} \quad (4.45)$$

and the energy density of the reflected wave is

$$E_r = \frac{|R|^2 P_i^2}{2\rho_0 c_0^2} e^{-2\text{Im}(k)[-x \cos \theta + z \sin \theta]}. \quad (4.46)$$

Note: by considering the simplified case where the plane is perfectly reflecting (here it would be perfectly rigid) and by ignoring the visco-thermal boundary layers effects, the reflection coefficient is equal to 1 and the impedance  $Z \rightarrow \infty$ . The above results still hold and the acoustic pressure field:

$$p = P_i \left[ e^{ik(x \cos \theta - z \sin \theta)} + e^{-ik(x \cos \theta + z \sin \theta)} \right]$$

can be written as

$$p = 2P_i \cos(kx \cos \theta) e^{-ikz \sin \theta}.$$

The above expression describes a system of stationary waves in the  $x$ -direction where the nodal planes, parallel to the  $x = 0$  plane, are separated by a distance

$$\frac{\pi}{\text{Re}(k) \cos \theta} = \frac{\lambda}{2 \cos \theta}.$$

This system of waves propagates in the  $z$ -direction with a speed equal to

$$c_z = \frac{\omega}{\text{Re}(k) \sin \theta} = \frac{c_0}{\sin \theta}.$$

**4.3.2. Reflection from a locally reacting surface in random incidence**

By definition, an acoustic field the incidence of which is qualified as random is a field that, at the boundaries, can be considered as a set of incoherent plane waves of equal intensity  $I$ , the directions of incidence being randomly distributed. The elementary intensity  $dI$  of the wave coming from the direction  $(\theta, \phi)$  defined with respect to a point on the surface is equal to the product of this intensity  $I$  (energy flux per unit of solid angle) and the area of the elementary solid angle:

$$dI = I \sin \theta d\theta d\phi$$

Consequently, the energy flux through the element of surface  $\delta S$  of the interface ( $yOz$  plane in Figure 4.2) located at the origin of the coordinate system, can be written as

$$d\phi_i = I \delta S \cos \theta \sin \theta d\theta d\phi$$

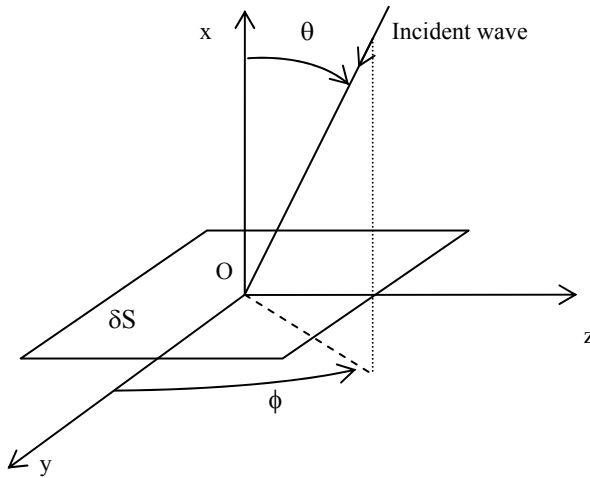

**Figure 4.2.** Coordinate system

By hypothesis, the total incident acoustic intensity is the sum of the intensities of all waves described above. Therefore, the total incident energy flux through  $\delta S$  is

$$\phi_i = I \delta S \int_0^{2\pi} d\phi \int_0^{\pi/2} \cos \theta \sin \theta d\theta = \pi I \delta S . \tag{4.47}$$



The expression of the energy flux  $\phi_a$  absorbed by the wall is obtained by writing that:

$$\phi_a = I \delta S \int_0^{2\pi} d\phi \int_0^{\pi/2} \alpha(\theta) \cos \theta \sin \theta d\theta. \quad (4.48)$$

Thus, the absorption coefficient in random incidence is given by

$$\alpha_m = \frac{\phi_a}{\phi_i} = \int_0^{\pi/2} \alpha(\theta) \sin(2\theta) d\theta, \quad (4.49)$$

or, replacing  $\alpha(\theta)$  by its expression (4.44):

$$\alpha_m = \frac{8}{|\zeta|} \cos \eta \left[ 1 + \frac{1}{|\zeta|} \frac{\cos(2\eta)}{\sin \eta} \operatorname{Atan} \left( \frac{|\zeta| \sin \eta}{1 + |\zeta| \cos \eta} \right) - \frac{\cos \eta}{|\zeta|} \log \left( 1 + 2|\zeta| \cos \eta + |\zeta|^2 \right) \right], \quad (4.50)$$

$$\text{with } \eta = \operatorname{Arctg} \frac{\operatorname{Im}(\zeta)}{\operatorname{Re}(\zeta)} \text{ and } \zeta = \frac{Z}{\rho_0 c_0}.$$

If the wall is poorly absorbing, ( $|\zeta|$  is great), this expression can be approximated by

$$\alpha_m = 8 \operatorname{Re} \left( \frac{1}{\zeta} \right). \quad (4.51)$$

### 4.3.3. Reflection of a harmonic spherical wave from a locally reacting plane surface

In such case one needs to express the incident spherical wave as the superposition of plane waves (equations (3.42) and (3.43)):

$$\frac{e^{-ikR}}{4\pi R} = \frac{1}{(2\pi)^3} \iiint \frac{e^{-i\vec{\chi}\cdot\vec{R}}}{\chi^2 - k^2} d^3\vec{\chi}, \quad (4.52)$$

and apply to each wave

$$\frac{1}{\chi^2 - k^2} \exp \left[ -i \left[ \chi_x (x - x_0) + \chi_y (y - y_0) + \chi_z (z - z_0) \right] \right], \quad (4.53)$$

the law of reflection of a plane wave (equations (4.40) and (4.41)) to obtain the corresponding reflected wave:

$$\frac{\zeta n_z - 1}{\zeta n_z + 1} \frac{1}{\chi^2 - k^2} \exp \left[ -i \left[ -\chi_x (x - x_0) + \chi_y (y - y_0) + \chi_z (z - z_0) \right] \right].$$

Finally, the total field can be written as

$$\frac{1}{(2\pi)^3} \iiint \frac{e^{-i[\chi_y(y-y_0)+\chi_z(z-z_0)]}}{\chi^2 - k^2} \left[ e^{-i\chi_x(x-x_0)} + \frac{\zeta n_z - 1}{\zeta n_z + 1} e^{i\chi_x(x-x_0)} \right] d^3\vec{\chi}, \quad (4.54)$$

where  $n_z = \chi_z / \chi$  is the cosine of the angle of incidence associated with the plane wave considered. This process is not detailed here.

**4.3.4. Acoustic field before a plane surface of impedance  $Z$  under the load of a harmonic plane wave in normal incidence**

The acoustic field before a plane surface (perpendicular to an  $\vec{O}x$  axis) of impedance  $Z$ , and under the load of a harmonic plane wave in normal incidence, can be written, according to the results of section 4.3.1, as

$$p = P_i \left[ e^{ikx} + R e^{-ikx} \right] = P_i \left[ 2R \cos(kx) + (1-R) e^{ikx} \right], \quad (4.55)$$

and, since  $k/k_0 \approx 1$ :

$$v = v_n \approx \frac{P_i}{\rho_0 c_0} \left[ e^{ikx} - R e^{-ikx} \right] = \frac{P_i}{\rho_0 c_0} \left[ i2R \sin(kx) + (1-R) e^{ikx} \right]. \quad (4.56)$$

Generally, these results are used over relatively short distances from the wall (few wavelengths) and in tubes (where the dissipation during propagation is due to the boundary layers), and consequently the complex wavenumber  $k$  (according to equation (4.7b)) does not come in useful. In a tube, equation (3.118) is more suitable. However, in most cases, the use of the real wavenumber  $k_0$  remains satisfactory.

Equations (4.55) and (4.56), for  $k = k_0$ , highlight the existence of a system of stationary waves of amplitudes  $2RP_i \cos(k_0x)$  on which is superposed a progressive wave traveling toward the wall of amplitude  $P_i(1-R)$ .

The intensity associated to this wave is

$$\begin{aligned}
 I &= \frac{1}{2} \operatorname{Re}[pv^*], \\
 &= \frac{P_1^2}{2\rho_0 c_0} \operatorname{Re} \left( [2R \cos(k_0 x) + (1-R)e^{ik_0 x}] [-2iR^* \sin(k_0 x) + (1-R^*)e^{-ik_0 x}] \right), \\
 &= \frac{P_1^2}{2\rho_0 c_0} \operatorname{Re} \left( -4i|R|^2 \cos(k_0 x) \sin(k_0 x) + |1-R|^2 \right. \\
 &\quad \left. + 2R(1-R^*)\cos(k_0 x) e^{-ik_0 x} - 2iR^*(1-R)\sin(k_0 x) e^{ik_0 x} \right). \quad (4.57)
 \end{aligned}$$

The two first terms correspond respectively to the individual intensities of the stationary and progressive waves. The intensity associated with the stationary wave alone is null. The two other factors reveal the interaction between the two waves. When all calculation is done, one obtains:

$$I = \frac{P_1^2}{2\rho_0 c_0} \left[ |1-R|^2 + R(1-R^*) + R^*(1-R) \right] = \frac{P_1^2}{2\rho_0 c_0} \left[ 1 - |R|^2 \right]. \quad (4.58)$$

The latter result is the same as equation (4.43). The energy flux is null when the waves are perfectly stationary ( $R = 1$ ).

If the complex reflection coefficient is written as

$$R = R_M e^{i\pi\sigma},$$

the pressure amplitude can be written as

$$p_M = P_1 \left( 1 + R_M^2 + 2R_M \cos \left[ 2k_0 \left( x - \frac{\sigma\lambda}{4} \right) \right] \right)^{1/2}. \quad (4.59)$$

In practice, it is the mean quadratic pressure that is measured. It is proportional to the amplitude  $p_M$ . The ratio of the maximum to the minimum of this amplitude depends on the amplitude  $R_M$  of the reflection coefficient:

$$\begin{aligned}
 \frac{p_M)_{\max}}{p_M)_{\min}} &= \left[ \frac{1 + R_M^2 + 2R_M}{1 + R_M^2 - 2R_M} \right]^{1/2} = \frac{1 + R_M}{1 - R_M}, \\
 \text{or } R_M &= \frac{p_M)_{\max}/p_M)_{\min} - 1}{p_M)_{\max}/p_M)_{\min} + 1}. \quad (4.60)
 \end{aligned}$$

The minima are localized at the points  $x_m (< 0)$  defined by

$$x_m = (2n + 1 + \sigma) \frac{\lambda}{4}, \tag{4.61}$$

where  $n = 0, 1, \text{etc.}$  denotes the order of the zeros of the pressure amplitude as numbered from the wall.

Thus, the measure of  $p_M)_{\max}$ ,  $p_M)_{\min}$  and  $x_m$  leads to the estimation of the complex reflection coefficient  $R$  in normal incidence, and subsequently of the impedance  $Z$  of the material given by  $Z = \rho_0 c_0 (1 + R) / (1 - R)$ .

The specific impedance  $Z = \frac{1}{\rho_0 c_0} \frac{P}{v}$  can here be written as

$$Z = -i \cotg(k_0 x + \psi) = -\coth[-i(k_0 x + \psi)], \tag{4.62}$$

denoting

$$\begin{cases} R = e^{-\mu} e^{i\pi\sigma} \\ p = P_i (e^{ik_0 x} + R e^{-ik_0 x}) = B \cos(k_0 x - \psi) \end{cases}$$

where  $B = 2P_i e^{i\psi}$  with  $\psi = \frac{\pi\sigma + i\mu}{2}$ .

#### 4.4. Reflection and transmission at the interface between two different fluids

##### 4.4.1. Governing equations

A plane wave of pressure  $p_1$  reaches, in oblique incidence, the interface  $x = 0$  between two different fluids media, which are denoted (1) and (2) and characterized by their respective elastic (compressibility), inertial (density) and dissipative characteristics (Figure 4.3).

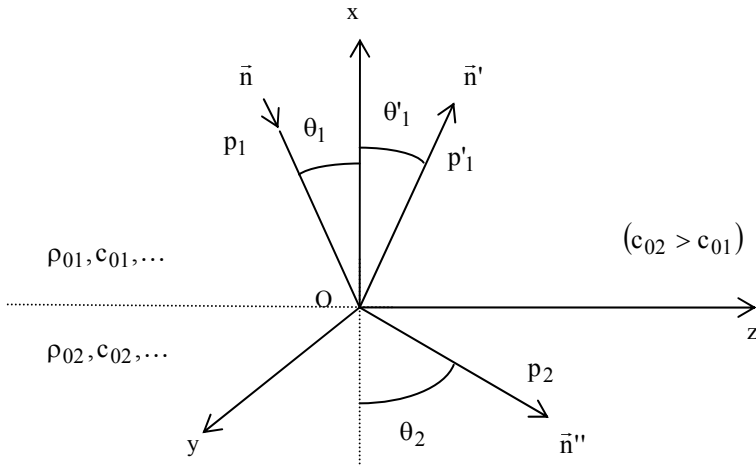

**Figure 4.3.** Reflection and transmission of a plane wave of amplitude  $p_1$  at the interface between two different fluid media

The x-axis, which is perpendicular to the (y, z) interface, is directed inward the incident medium. For the sake of simplicity, the media are considered non-dissipative.

The problem can then be written as

$$\begin{cases} \left[ \frac{\partial^2}{\partial x^2} + \frac{\partial^2}{\partial y^2} + \frac{\partial^2}{\partial z^2} - \frac{1}{c_{01}^2} \frac{\partial^2}{\partial t^2} \right] p_0(x, y, z, t) = 0, & \forall x \geq 0, y, z, t, \\ \left[ \frac{\partial^2}{\partial x^2} + \frac{\partial^2}{\partial y^2} + \frac{\partial^2}{\partial z^2} - \frac{1}{c_{02}^2} \frac{\partial^2}{\partial t^2} \right] p_2(x, y, z, t) = 0, & \forall x \leq 0, y, z, t, \\ p_0(0, y, z, t) = p_2(0, y, z, t), & \forall y, z, t, \\ \frac{1}{\rho_{01} c_{01}} \frac{\partial}{\partial x} p_0(0, y, z, t) = \frac{1}{\rho_{02} c_{02}} \frac{\partial}{\partial x} p_2(0, y, z, t), & \forall y, z, t, \end{cases}$$

where  $p_0 = p_1 + p'_1$  denotes the total acoustic field in the incident medium, and  $p_1 = f\left(t - \frac{\vec{n} \cdot \vec{r}}{c_{01}}\right)$  denotes the incident plane wave generated by a source located at infinity ( $x > 0$ ).

#### 4.4.2. The solutions

The acoustic pressure fields can be written as in section 4.2.1:

$$p_1 = f\left(t - \frac{\vec{n} \cdot \vec{r}}{c_{01}}\right), \quad (4.63a)$$

$$p'_1 = f\left(t - \frac{\vec{n}' \cdot \vec{r}}{c_{01}}\right), \quad (4.63b)$$

$$p_2 = f\left(t - \frac{\vec{n}'' \cdot \vec{r}}{c_{02}}\right), \quad (4.63c)$$

where the unit vectors  $\{\vec{n}, \vec{n}', \vec{n}''\}$  denote respectively the directions of propagation of the incident wave  $p_1$ , the reflected wave  $p'_1$  and the transmitted wave  $p_2$ . At the boundary  $x = 0$ , the instantaneous fields  $(p_1 + p'_1)$  and  $p_2$  must be equal at any point and time. Thus, the argument of the functions  $f$  are equal  $\forall(0, y, z, t)$ :

$$t - \frac{\vec{n} \cdot \vec{r}}{c_{01}} = t - \frac{\vec{n}' \cdot \vec{r}}{c_{01}} = t - \frac{\vec{n}'' \cdot \vec{r}}{c_{02}}, \quad \forall(y, z, t), \quad (4.64a)$$

$$\frac{n_y y + n_z z}{c_{01}} = \frac{n'_y y + n'_z z}{c_{01}} = \frac{n''_y y + n''_z z}{c_{02}}, \quad \forall(y, z), \quad (4.64b)$$

implying that:

$$\frac{n_y}{c_{01}} = \frac{n'_y}{c_{01}} = \frac{n''_y}{c_{02}} \quad \text{and} \quad \frac{n_z}{c_{01}} = \frac{n'_z}{c_{01}} = \frac{n''_z}{c_{02}}. \quad (4.64c)$$

The plane defined by the direction of the incident wave  $\vec{n}$  and the normal  $(\vec{Ox})$  to the interface is called the plane of incidence. Equations (4.64c) show that  $\vec{n}'$  and  $\vec{n}''$  are also in this plane. By choosing this plane as the plane  $(xOz)$ , and using the notations of Figure 4.3:

$$n_x = -\cos \theta_1, \quad n'_x = \cos \theta_1, \quad n''_x = -\cos \theta_2 \quad (4.65)$$

$$\text{and } n_z = \sin \theta_1, \quad n'_z = \sin \theta_1, \quad n''_z = \sin \theta_2. \quad (4.66)$$

By considering the system of equations (4.64b), one obtains the following relations:

$$\begin{aligned} \sin \theta_1 &= \sin \theta_1', \\ \text{or } \theta_1 &= \theta_1' \text{ since } \theta_1, \theta_1' < \pi/2, \end{aligned} \quad (4.67)$$

$$\text{and } \frac{\sin \theta_1}{c_{01}} = \frac{\sin \theta_2}{c_{02}}. \quad (4.68)$$

These are the refraction laws of Snell-Descartes.

If the speed of sound in the second medium is greater than that in the first medium, there exists a limit value  $\theta_L$  of the angle of incidence given by  $\frac{c_{02}}{c_{01}} \sin \theta_L = 1$ . Above this limit, the angle  $\theta_2$  is not real anymore and the reflection is “total”.

#### 4.4.3. Solutions in harmonic regime

The discussion is furthered by considering harmonic incident fields and generalizing the argument to any type of signal by means of Fourier transforms (the dissipation is ignored).

The amplitudes of the pressure fields are written as

$$p_0 = p_1 + p_1' = P_1 \left[ e^{ik_{01}(x \cos \theta_1 - z \sin \theta_1)} + R e^{-ik_{01}(x \cos \theta_1' + z \sin \theta_1')} \right], \quad (4.69)$$

$$p_2 = P_1 T e^{ik_{02}(x \cos \theta_2 - z \sin \theta_2)}. \quad (4.70)$$

The two equations of continuity at the interface on the acoustic pressure:

$$p_0)_{x=0} = p_2)_{x=0}, \quad \forall(z, t), \quad (4.71)$$

satisfied assuming the Snell-Descartes law if

$$1 + R = T, \quad (4.72)$$

and on acoustic particle velocity:

$$v_0)_{x=0} = v_2)_{x=0}, \quad \forall(z, t),$$

lead to

$$\frac{1}{\rho_{01}c_{01}}(1-R)\cos\theta_1 = \frac{T}{\rho_{02}c_{02}}\cos\theta_2, \quad (4.73)$$

or, dividing by equation (4.72), to

$$\frac{1+R}{1-R} = \frac{\rho_{02}c_{02}}{\rho_{01}c_{01}} \frac{\cos\theta_1}{\cos\theta_2}. \quad (4.74)$$

Equation (4.74) leads to the expression of the reflection coefficient (amplitude):

$$R = \frac{\zeta\cos\theta_1 - \cos\theta_2}{\zeta\cos\theta_1 + \cos\theta_2} \text{ where } \zeta = \frac{\rho_{02}c_{02}}{\rho_{01}c_{01}}. \quad (4.75)$$

The substitution of the Snell-Descartes law into equation (4.75) yields:

$$R = \frac{\zeta\cos\theta_1 - \sqrt{1 - \left(\frac{c_{02}}{c_{01}}\sin\theta_1\right)^2}}{\zeta\cos\theta_1 + \sqrt{1 - \left(\frac{c_{02}}{c_{01}}\sin\theta_1\right)^2}} \quad (4.76)$$

and the transmission coefficient (amplitude):

$$T = 1 + R = \frac{2\zeta\cos\theta_1}{\zeta\cos\theta_1 + \sqrt{1 - \left(\frac{c_{02}}{c_{01}}\sin\theta_1\right)^2}}. \quad (4.77)$$

If the speed of sound in the medium (2) is greater than that in the medium (1), there exists a limit value  $\theta_L$  for the angle of incidence above which  $\theta_2$  given by

$\sin\theta_2 = \frac{c_{02}}{c_{01}}\sin\theta_1 > 1$  is not real anymore. In such condition, the modulus of the

reflection coefficient is equal to one:

$$|R| = \frac{\left| \zeta\cos\theta_1 - i\sqrt{\left(\frac{c_{02}}{c_{01}}\sin\theta_1\right)^2 - 1} \right|}{\left| \zeta\cos\theta_1 + i\sqrt{\left(\frac{c_{02}}{c_{01}}\sin\theta_1\right)^2 - 1} \right|} = 1. \quad (4.78)$$



This result shows that there is total reflection of the incident wave. In grazing incidence ( $\theta_1 = \pi/2$ ),  $R = -1$ . This indicates that there is a change of phase during the reflection. However, the transmission coefficient  $T = 1 + R$  is not necessarily equal to zero (except in grazing incidence). There is an apparent ambiguity here that does not really exist. In a stationary regime, there is no real energy flux that propagates along the  $Ox$  direction in the medium (2). Actually, since

$$\sin \theta_2 = \frac{c_{02}}{c_{01}} \sin \theta_1,$$

$$\text{then } \cos \theta_2 = \pm i \sqrt{\left(\frac{c_{02}}{c_{01}} \sin \theta_1\right)^2 - 1}, \quad (4.79)$$

the amplitude of the pressure  $p_2$  takes the following form:

$$p_2 = P_i T \exp \left[ \mp k_{02} \sqrt{\left(\frac{c_{02}}{c_{01}}\right)^2 \sin^2 \theta_1 - 1} x \right] \exp \left[ ik_{02} \frac{c_{02}}{c_{01}} z \sin \theta_1 \right]. \quad (4.80)$$

This is the expression of a wave that propagates at the interface between the two fluids, on the side of medium (2), in the positive  $z$ -direction and that decreases exponentially with the depth  $x$ . The negative sign before the square root does not correspond to any physical situation, describing a wave of amplitude tending to infinity with the distance (Sommerfeld's condition, assumed herein).

#### 4.4.4. The energy flux

The energy conservation law (equation (1.84)) is written, for  $\theta_1 < \theta_L$  as

$$\frac{P_1^2 \cos \theta_1}{2\rho_{01} c_{01}} = \frac{P_1^2 R^2 \cos \theta_1}{2\rho_{01} c_{01}} + \frac{P_1^2 T^2 \cos \theta_2}{2\rho_{02} c_{02}}, \quad (4.81)$$

$$\text{or } 1 = R^2 + \frac{\cos \theta_2}{\cos \theta_1} \frac{T^2}{\zeta}, \quad (4.82)$$

where the second term (i.e., the fraction which depends on  $\theta_1$  and  $\theta_2$ ) denotes the sum of the reflection coefficient and the transmission coefficient (in terms of energy).

However, for  $\theta_1 > \theta_L$ , the intensity transmitted to the medium (2) in the  $\vec{Ox}$  direction, calculated from the corresponding expression of  $p_2$  (4.80), is written as:

$$I_{x_2} \Big|_{\theta_1 > \theta_L} = \frac{1}{4} \frac{i}{k_{02} \rho_{02} c_{02}} \left[ p_2^* \frac{\partial}{\partial x} p_2 - p_2 \frac{\partial}{\partial x} p_2^* \right] \tag{4.83}$$

and, since  $\frac{\partial p_2}{\partial x}$  is of the form  $(\alpha p_2)$  with  $\alpha$  real:

$$I_{x_2} \Big|_{\theta_1 > \theta_L} = 0. \tag{4.84}$$

This supports the concept of total reflection.

Note: in normal incidence,  $R = \frac{\zeta - 1}{\zeta + 1}$ ,  $T = \frac{2\zeta}{\zeta + 1}$  and the transmission coefficient (in energy) is  $\alpha_T = T^2 / \zeta$ .

If  $\zeta \ll 1$ ,  $R \approx -1$  and  $T \approx 0$ , there is quasi-total reflection with a phase shift at the reflection (water–air interface for example).

If  $\zeta \gg 1$ ,  $R \approx 1$  and  $T \approx 2$ , the pressure at the interface is twice the incident pressure (air–water interface for example).

For the air–water interface ( $\zeta \approx 3.6 \cdot 10^3$ ), the transmission coefficient (in terms of energy) is equal to

$$\alpha_T = \frac{T^2}{\zeta} = \frac{4}{3.6 \cdot 10^3} \approx \frac{1}{900}.$$

Only a small fraction of the incident power is transmitted (due to the strong impedance discontinuity  $\rho_0 c_0$ ).

## 4.5. Harmonic waves propagation in an infinite waveguide with rectangular cross-section

### 4.5.1. The governing equations

The column of fluid contained in a tube (waveguide) with rectangular cross-section, of dimensions  $L_x$  and  $L_y$  and of infinite length, is submitted to a

harmonic acoustic field generated upstream from the tube and propagating along the  $\vec{Oz}$  axis of the tube. The walls of the guide are assumed perfectly rigid so that the energy dissipation is due to the visco-thermal effects within the boundary layers; the dissipation within the fluid and expressed by the wavenumber

$$k_a = k_0(1 - ik_0 \ell_{vh} / 2) \text{ (equation (2.86))}$$

remains negligible compared to the boundary layers' dissipation that is taken into account by when considering the equivalent impedance  $Z_a$  (equation (3.10)). *A priori*, the wave propagates by means of multiple reflections on the walls (in oblique incidences) so that in each transverse direction, it behaves as the superposition of two interfering acoustic waves propagating in opposite directions and resulting in a stationary state. However, the propagation is assumed (by hypothesis) unidirectional along the  $\vec{Oz}$  axis (since there is no reflection at the ends of an infinite tube) and toward the positive  $z$ . The origin of the coordinate system is taken on the edge of the tube (Figure 4.4).

The objective of this exercise is to express the acoustic field and to describe its principal characteristics. The problem can be written, assuming  $k_a \sim k_0$  and suppressing the factor  $e^{i\omega t}$  throughout, as

$$\left\{ \begin{array}{l} \left[ \frac{\partial^2}{\partial x^2} + \frac{\partial^2}{\partial y^2} + \frac{\partial^2}{\partial z^2} + k_0^2 \right] p(x, y, z) = 0, \quad \forall x \in (0, L_x), \quad \forall y \in (0, L_y), \quad \forall z > z_s, \\ \frac{\partial p}{\partial x} = ik_0 \beta_{ax} p, \quad x = 0, \quad \forall y, z, \\ \frac{\partial p}{\partial x} = -ik_0 \beta_{ax} p, \quad x = L_x, \quad \forall y, z, \\ \frac{\partial p}{\partial y} = ik_0 \beta_{ay} p, \quad y = 0, \quad \forall x, z, \\ \frac{\partial p}{\partial y} = -ik_0 \beta_{ay} p, \quad y = L_y, \quad \forall x, z, \end{array} \right. \quad (4.85)$$

Harmonic wave  $e^{i\omega t}$  generated upstream from the considered domain (source located at  $z < 0$ ) and propagating in the positive  $z$ -direction.

where (equation (3.10)):

$$\beta_{ax} = \frac{1+i}{\sqrt{2}} \sqrt{k_0} \left[ \left( 1 - \frac{k_{0x}^2}{k_0^2} \right) \sqrt{\ell'_v} + (\gamma-1) \sqrt{\ell'_h} \right],$$

$$\beta_{ay} = \frac{1+i}{\sqrt{2}} \sqrt{k_0} \left[ \left( 1 - \frac{k_{0y}^2}{k_0^2} \right) \sqrt{\ell'_v} + (\gamma-1) \sqrt{\ell'_h} \right],$$

$k_0 = \omega / c_0$  imposed by the sources (forced motion).

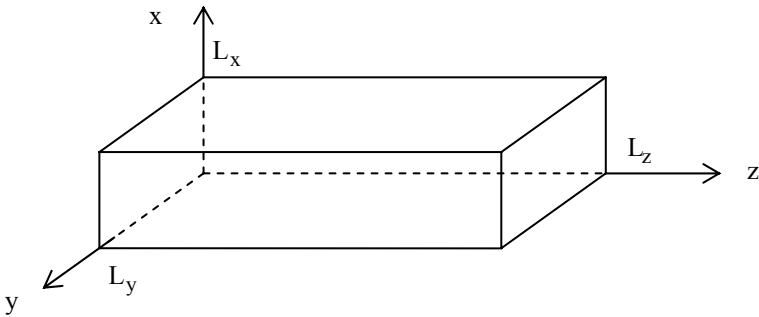

**Figure 4.4.** Waveguide with rectangular cross-section

#### 4.5.2. The solutions

One can, after a lengthy, but not difficult, derivation, verify that, at the first order of the quantities  $\beta_{ax}$  and  $\beta_{ay}$ , the solutions can be approximated by  $\Psi_{mn}(x, y) e^{-ik_{zmn}z} e^{i\omega t}$ , with:

$$\Psi_{mn} = \begin{cases} \cos\left(k_m x - i \frac{k_0 L_x}{m\pi} \beta_{axm}\right) \cos\left(k_n y - i \frac{k_0 L_y}{n\pi} \beta_{ayn}\right), & m, n \neq 0, \\ 1, & m, n = 0, \end{cases} \quad (4.86)$$

$$k_0^2 = k_m^2 + k_n^2 + k_{zmn}^2, \quad (4.87)$$

$$k_m^2 = \left(\frac{m\pi}{L_x}\right)^2 + i(2 - \delta_{m0}) \frac{2k_0 \beta_{axm}}{L_x}, \quad (4.88a)$$

$$k_n^2 = \left(\frac{n\pi}{L_y}\right)^2 + i(2 - \delta_{n0}) \frac{2k_0 \beta_{ayn}}{L_y}, \quad (4.88b)$$

where the quantum numbers  $n$  and  $m$  are integers ( $m, n = 0, 1, 2, \text{etc.}$ ) and where the specific admittances  $\beta_{am}$  and  $\beta_{an}$  correspond respectively to the quantities  $\beta_{ax}$  and  $\beta_{ay}$ , in which the parameters  $k_{0x}^2$  and  $k_{0y}^2$  are replaced by their respective approximated expressions  $(m\pi/L_x)^2$  and  $(n\pi/L_y)^2$ .

The general solution is obtained by superposing all the particular solutions as follows:

$$p = \sum_{m,n=0}^{\infty} A_{mn} \psi_{mn}(x, y) e^{-ik_{zmn}z} e^{i\omega t}, \quad (4.89)$$

where the coefficients  $A_{mn}$  denote the integration constants, the values of which can be determined by the conditions at the source (this is, however, not developed herein).

If a reflected wave is present, the solution could then be written as

$$p = \sum_{m,n=0}^{\infty} \psi_{mn}(x, y) [A_{mn} e^{-ik_{zmn}z} + B_{mn} e^{ik_{zmn}z}] e^{i\omega t}, \quad (4.90)$$

introducing a double set of integration constants  $A_{mn}$  and  $B_{mn}$ .

In case dissipation is ignored, the solutions can be written as

$$\psi_{mn} = \cos\left(\frac{m\pi}{L_x}x\right) \cos\left(\frac{n\pi}{L_y}y\right) \quad (4.91a)$$

or as

$$\psi_{mn} = \sqrt{\frac{2-\delta_{m0}}{L_x}} \sqrt{\frac{2-\delta_{n0}}{L_y}} \cos\left(\frac{m\pi}{L_x}x\right) \cos\left(\frac{n\pi}{L_y}y\right). \quad (4.91b)$$

The latter form is more widely used as the corresponding admissible orthogonal functions  $\psi_{mn}$  are normalized:

$$\int_0^{L_x} dx \int_0^{L_y} dy \psi_{mn} \psi_{\mu\nu} = \delta_{m\mu} \delta_{n\nu}. \quad (4.92)$$

A set of eigenvalues  $k_{mn} = \sqrt{k_m^2 + k_n^2}$  are associated with these eigenfunctions. A more general development on the problem of eigenvalues is given in the Appendix.

### 4.5.3. Propagating and evanescent waves

The factor  $e^{-ik_{zmn}z}$  does not necessarily describe a propagating wave. In other words, in the solution (4.89), only certain modes – those for which quantum numbers are the smallest – contribute to the propagation. The others, which are evanescent, present exponentially decreasing amplitudes. To emphasize this statement, the mode  $m = n = 0$  is treated on its own as if it was a particular case.

#### 4.5.3.1. Mode $m = n = 0$

In the following,  $k_0$  always denotes the ratio  $\omega/c_0$  where  $c_0$  is the adiabatic speed of sound and  $\omega$  the angular frequency of the source (forced motion). The square of the propagation constant  $k_{zmn}^2 = k_0^2 - k_m^2 - k_n^2$  from equation (4.88) can be written, when  $m = n = 0$ , as

$$k_{z00}^2 = k_0^2 - i \frac{1+i}{\sqrt{2}} \frac{2(L_x + L_y)}{L_x L_y} k_0^{3/2} \left[ \sqrt{\ell'_v} + (\gamma-1)\sqrt{\ell'_h} \right], \quad (4.93)$$

or, denoting

$$\eta_0 = \frac{1}{\sqrt{2}} \frac{2(L_x + L_y)}{L_x L_y} \frac{1}{\sqrt{k_0}} \left[ \sqrt{\ell'_v} + (\gamma-1)\sqrt{\ell'_h} \right], \quad (4.94)$$

as

$$k_{z00}^2 = k_0^2 [1 + (1-i)\eta_0], \quad (4.95)$$

where the imaginary part represents an exponentially decreasing wave. The latter result is to be compared to that for the plane wave propagating in a cylindrical tube:

$$k_z^2 \approx k_0^2 [1 + (1-i)\eta], \quad (\text{equation (3.118)})$$

$$\text{with } \eta = \frac{1}{\sqrt{2}} \frac{2}{R} \frac{1}{\sqrt{k_0}} \left[ \sqrt{\ell'_v} + (\gamma-1)\sqrt{\ell'_h} \right].$$

These expressions of the propagation constant along the  $(\vec{O}z)$  are equivalent since the factors  $(2/R)$  and  $2(L_x + L_y)/(L_x L_y)$  denote, in both cases, the ratio of the perimeter to the cross-sectional area of the tube.

The mode  $m = n = 0$  depends very little, and if dissipation is completely ignored does not depend at all, on the  $x$  and  $y$  variables. It is called “quasi-plane” mode. The associated constant of propagation is

$$k_{z00} \approx k_0 \left[ 1 + \frac{1-i}{2} \eta_0 \right]. \quad (4.96)$$

The real part of the above equation is always close to  $k_0$ , the phase velocity of the wave (speed of propagation of the wave along the  $Oz$ -axis) is equal to the adiabatic speed  $c_0$  and its attenuation follows the same law as the attenuation of a classical, guided plane wave (equation (3.122)):

$$\Gamma = \frac{L_x + L_y}{L_x L_y} \sqrt{\frac{k_0}{2}} \left[ \sqrt{\ell'_v} + (\gamma-1)\sqrt{\ell'_h} \right]. \quad (4.97)$$

This mode is qualified as propagative.

#### 4.5.3.2. Modes $m$ and/or $n \neq 0$

The set of equations (4.87) and (4.88) leads to

$$k_{zmn}^2 = k_0^2 - \left( \frac{m\pi}{L_x} \right)^2 - \left( \frac{n\pi}{L_y} \right)^2 + (1-i)(v_m + v_n), \quad (4.98)$$

with

$$v_m = \frac{1}{\sqrt{2}} \frac{2(2-\delta_{m0})}{L_x} k_0^{3/2} \left( \left[ 1 - \left( \frac{m\pi}{k_0 L_x} \right)^2 \right] \sqrt{\ell'_v} + (\gamma-1)\sqrt{\ell'_h} \right), \quad (4.99a)$$

$$v_n = \frac{1}{\sqrt{2}} \frac{2(2-\delta_{n0})}{L_y} k_0^{3/2} \left( \left[ 1 - \left( \frac{n\pi}{k_0 L_y} \right)^2 \right] \sqrt{\ell'_v} + (\gamma-1)\sqrt{\ell'_h} \right). \quad (4.99b)$$

The factors  $(2-\delta_{m0})$  and  $(2-\delta_{n0})$  denote the number of reflections on the walls per cycle. This expression of the constant of propagation for the  $(m,n)^{\text{th}}$  mode is to be examined in three different situations.

If  $\text{Re}[k_{zmn}^2] \approx 0$ , the frequency of the wave, called cut-off frequency, is such that  $k_0^2 \approx (m\pi/L_x)^2 + (n\pi/L_y)^2$ . The real and imaginary parts of  $k_{zmn}$  are very small (of similar magnitude as  $v_m$  and  $v_n$ ) and the phase velocity associated to the  $(m,n)^{\text{th}}$  mode is great (it tends to infinity when dissipation is neglected). The wave

associated to this mode oscillates between the walls under normal incidence, the planes of equal phase are parallel to the main axis of the tube and consequently the phase does not depend on the  $z$  variable, resulting in a phase velocity tending to infinity. The attenuation remains small. The energy flux in the  $z$ -direction associated to this mode tends to zero.

The two other situations correspond to the  $(m, n)$  modes that are such that:

$$\left| k_0^2 - (m\pi/L_x)^2 - (n\pi/L_y)^2 \right| > |v_m + v_n|,$$

where the frequency of the wave is not near the cut-off frequency of the  $(m, n)^{\text{th}}$  mode considered. Equation (4.98) can then be written as

$$k_{zmn}^2 = \left[ k_0^2 - (m\pi/L_x)^2 - (n\pi/L_y)^2 \right] \left[ 1 + (1-i)(\eta_m + \eta_n) \right], \quad (4.100)$$

$$\text{with } \eta_m = \frac{v_m}{k_0^2 - (m\pi/L_x)^2 - (n\pi/L_y)^2}$$

$$\text{and } \eta_n = \frac{v_n}{k_0^2 - (m\pi/L_x)^2 - (n\pi/L_y)^2}. \quad (4.101)$$

Two types of modes are introduced depending of the sign of the  $\text{Re}[k_{zmn}^2]$ .

The modes where  $\text{Re}[k_{zmn}^2] > 0$  have an eigenfrequency smaller than the frequency of the wave  $(m\pi/L_x)^2 + (n\pi/L_y)^2 < k_0^2$ . These modes for which the real part of  $k_{zmn}$  is finite have an associated wave, of which the phase velocity in the  $z$ -direction is

$$c_{\phi mn} = \frac{\omega}{k_{zmn}} \approx \frac{\omega}{\sqrt{k_0^2 - (m\pi/L_x)^2 - (n\pi/L_y)^2}}. \quad (4.102)$$

The modes where  $\text{Re}[k_{zmn}^2] < 0$  have an eigenfrequency greater than the frequency of the wave  $(m\pi/L_x)^2 + (n\pi/L_y)^2 > k_0^2$ . These modes, for which the real part of  $k_{zmn}$  is almost null and the imaginary part is finite (the visco-thermal terms  $\eta_m$  and  $\eta_n$  are not worth considering), have an associated wave that is exponentially decreasing and exists only at the vicinity of its source (any discontinuity in the tube). This mode is qualified as evanescent.



It is clear that all modes, but  $(m = 0, n = 0)$ , can be either propagative or evanescent. The  $(0,0)^{\text{th}}$  can only be propagative. Consequently, any tube where the dimension and cut-off frequency are such that all modes that have at least a non-null quantum number are evanescent can only carry plane waves. In these conditions and outside the zone of perturbation (source, discontinuities, etc.), these tubes are seen as plane wave generators.

Note: the eigenvalues of a rectangular cavity are obtained by replacing  $k_{zmn}^2$  in equation (4.98) with  $[(\ell\pi/L_z)^2 - (1-i)v_\ell]$ ,  $k_0$  then representing the eigenvalues is denoted  $k_{mn\ell}$ . The associated eigenfunctions are a simple extension of equations (4.91) including the 3rd dimension  $z$  (see Chapter 6).

#### 4.5.4. Guided propagation in non-dissipative fluid

This section summarizes and details the previous developments where, for the sake of simplicity, dissipation is ignored ( $\beta_a = 0$ ).

##### 4.5.4.1. Modes with one null quantum number

Considering first the modes with one null quantum number ( $n_y = 0$  for example) leads to

$$\varphi_{m0} = \cos\left(\frac{m\pi}{L_x}x\right), \tag{4.103}$$

$$k_{zm0}^2 = k_0^2 - \left(\frac{m\pi}{L_x}\right)^2, \tag{4.104}$$

$$p = \sum_m A_{m0} \cos\left(\frac{m\pi}{L_x}x\right) e^{-ik_{zm0}z} e^{i\omega t}. \tag{4.105}$$

Each term of this series can yet be written in the following form:

$$\frac{1}{2} A_{m0} \left( \exp\left[ i\left(\frac{m\pi}{L_x}x - k_{zm0}z\right) \right] + \exp\left[ -i\left(\frac{m\pi}{L_x}x + k_{zm0}z\right) \right] \right) e^{i\omega t}. \tag{4.106}$$

Equation (4.105) highlights the behavior of the modal wave (assuming the mode is propagative) as the sum of two propagative oblique waves the directions of which propagation are given by

$$\sin \theta = \pm \frac{m\pi}{k_0 L_x}. \tag{4.107}$$

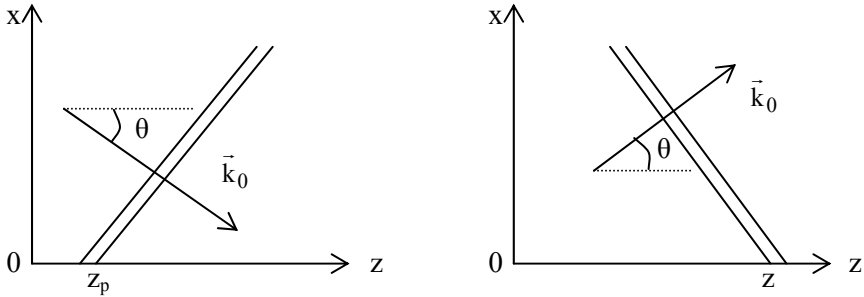

**Figure 4.5.** Decomposition of the propagating mode into two plane waves, the double line represents the surface of equal phase

The speed of each wave front (phase velocity for each wave front) is equal to  $c_0 = \omega/k_0$ . The phase velocity of the wave planes, along the  $\vec{Oz}$  axis, velocity at the intersection  $z_p$  (Figure 4.5) of the considered wave plane with the walls is given by

$$c_{\phi m0} = \frac{\omega}{k_{zm0}} = \frac{\omega}{k_0} \frac{k_0}{k_{zm0}} = \frac{c_0}{\cos \theta} > c_0. \tag{4.108}$$

It tends toward infinity if  $\theta = \pi/2$  or, in other words, when  $k_{zm0} \approx 0$  and  $k_0 \approx m\pi/L_x$  (the frequency is equal to the cut-off frequency, i.e.  $f_0 = (c_0/2)(m/L_x)$ ).

The projection  $c_g)_{mn}$  of the wave speed  $c_0$  associated with the  $(m,0)$  mode onto the  $\vec{Oz}$  axis (Figure 4.6) can be written as

$$c_g)_{m0} = c_0 \cos \theta = c_0 \frac{k_{zm0}}{k_0}. \tag{4.109}$$

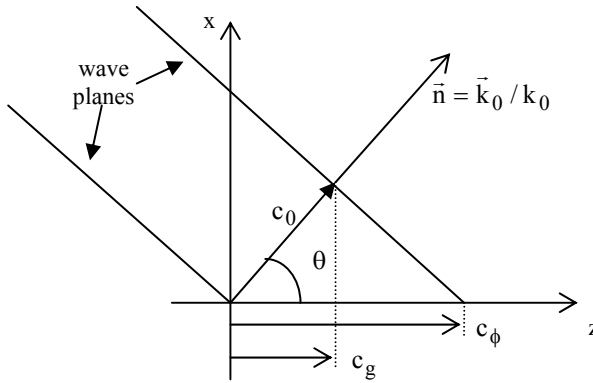

**Figure 4.6.** Characteristics of propagation of an oblique wave plane

A simple derivation shows that this quantity is equal to the group velocity along the  $\bar{O}z$  axis defined by

$$c_g)_{m0} = \frac{\partial\omega}{\partial k_{zm0}} = \left( \frac{\partial k_{zm0}}{\partial\omega} \right)^{-1}, \tag{4.110}$$

since

$$\begin{aligned} \frac{\partial}{\partial\omega} k_{zm0} &= \frac{\partial}{\partial\omega} \sqrt{\frac{\omega^2}{c_0^2} - \left( \frac{m\pi}{L_x} \right)^2}, \\ &= \frac{\omega}{c_0^2} \frac{1}{\sqrt{\frac{\omega^2}{c_0^2} - \left( \frac{m\pi}{L_x} \right)^2}} = \frac{k_0}{c_0 k_{zm0}} = \frac{1}{c_g)_{m0}}. \end{aligned} \tag{4.111}$$

This group velocity is equal, for any given mode, to the ratio of the mean energy flux to the mean density of energy through a section of the guide. It represents the speed of propagation of the energy along the main axis of the tube (to compare with the equivalent result of the previous section). It vanishes at the cut-off frequency.

4.5.4.2. Modes with general quantum numbers

In the “general” case where  $m$  and  $n$  are non-null for non-dissipative fluids, the various factors considered can be written as:

- the square of the constant of propagation

$$k_{zmn}^2 = k_0^2 - \frac{m^2 \pi^2}{L_x^2} - \frac{n^2 \pi^2}{L_y^2}, \quad (4.112)$$

– the speed of sound

$$c_0 = \frac{\omega}{k_0}, \quad (4.113)$$

– the phase velocity in the  $\vec{Oz}$  direction

$$c_{\phi mn} = \frac{\omega}{k_{zmn}} = c_0 \frac{k_0}{k_{zmn}} = c_0 \left[ 1 - \frac{1}{k_0^2} \left( \frac{m^2 \pi^2}{L_x^2} + \frac{n^2 \pi^2}{L_y^2} \right) \right]^{-1/2}, \quad (4.114)$$

– the group velocity in the  $\vec{Oz}$  direction

$$c_{g)mn} = \frac{\partial \omega}{\partial k_{zmn}} = c_0 \frac{k_{zmn}}{k_0} = c_0 \left[ 1 - \frac{1}{k_0^2} \left( \frac{m^2 \pi^2}{L_x^2} + \frac{n^2 \pi^2}{L_y^2} \right) \right]^{1/2}, \quad (4.115)$$

– the cut-off frequency of the  $(m, n)^{\text{th}}$  mode

$$f_{m,n} = \frac{c_0}{2} \sqrt{\left( \frac{m}{L_x} \right)^2 + \left( \frac{n}{L_y} \right)^2}, \quad (4.116)$$

– the general solution in the form of a double Fourier series for propagation in both directions ( $B_{mn} = 0$  without reflected wave)

$$p = \sum_{m,n=0}^{\infty} \psi_{mn}(x, y) [A_{mn} e^{-ik_{zmn}z} + B_{mn} e^{ik_{zmn}z}] e^{i\omega t} \quad (4.117)$$

$$\text{with } \psi_{mn} = \cos\left(\frac{m\pi}{L_x} x\right) \cos\left(\frac{n\pi}{L_y} y\right).$$

#### 4.5.4.3. Modal energy flux

The previous developments on the nature of the waves associated with the modes of a guide can be summarized by calculating the intensity of a wave along the  $\vec{Oz}$  axis of the guide. The projection onto this axis of the particle velocity is written as

$$v_z = \frac{i}{k_0 \rho_0 c_0} \frac{\partial p}{\partial z} = \frac{1}{k_0 \rho_0 c_0} \sum_{m,n} A_{mn} \psi_{mn} k_{zmn} e^{-ik_{zmn}z} e^{i\omega t}. \quad (4.118)$$

The intensity of the wave in the same direction then becomes

$$I_z = \frac{1}{4} (\overline{pv}_z^* + \overline{p^* v_z}),$$

$$= \frac{1}{2k_0 \rho_0 c_0} \operatorname{Re} \left[ \sum_{mnqr} \psi_{mn} \psi_{qr} A_{qr} A_{mn}^* k_{zmn}^* e^{-ik_{zqr} z} e^{ik_{zmn}^* z} \right], \quad (4.119)$$

and the energy flux through the section of the guide can be written as

$$\phi_z = \frac{1}{2k_0 \rho_0 c_0} \sum_{mnqr} \operatorname{Re} \left[ A_{qr} A_{mn}^* k_{zmn}^* e^{-i(k_{zqr} - k_{zmn}^*)z} \right]$$

$$\times \int_0^{L_x} \cos\left(\frac{m\pi x}{L_x}\right) \cos\left(\frac{q\pi x}{L_x}\right) dx \int_0^{L_y} \cos\left(\frac{n\pi y}{L_y}\right) \cos\left(\frac{r\pi y}{L_y}\right) dy; \quad (4.120)$$

or, denoting

$$\varepsilon_{mn} = \frac{1}{(2 - \delta_{m0})(2 - \delta_{n0})}, \quad (4.121)$$

and considering the orthogonality of the modes

$$\sqrt{\frac{2 - \delta_{m0}}{L_x}} \sqrt{\frac{2 - \delta_{q0}}{L_x}} \int_0^{L_x} \cos\left(\frac{m\pi x}{L_x}\right) \cos\left(\frac{q\pi x}{L_x}\right) dx = \delta_{mq}, \quad (4.122)$$

as:

$$\phi_z = \frac{L_x L_y}{2k_0 \rho_0 c_0} \sum_{mn} |A_{mn}|^2 \operatorname{Re}[k_{zmn}] e^{2\operatorname{Im}[k_{zmn}]z} \varepsilon_{mn}. \quad (4.123)$$

Equation (4.123) is of the form  $\phi_z = \sum_{mn} \phi_z)_{mn}$ .

If the  $(m, n)^{\text{th}}$  mode is evanescent ( $f < f_{mn}$ ), then  $k_{zmn}$  is a pure imaginary number and  $\phi_z)_{mn} = 0$ .

If the  $(m, n)^{\text{th}}$  mode is propagative ( $f > f_{mn}$ ), then  $k_{zmn}$  is a real number and

$$\phi_z)_{mn} = \frac{L_x L_y}{2\rho_0 c_0} \frac{k_{zmn}}{k_0} |A_{mn}|^2 \varepsilon_{mn}.$$

Thus, by denoting  $(m_0, n_0)$  the couple of quantum numbers such that the frequency  $f_{m_0 n_0}$  is as close as possible (yet always inferior) to the excitation frequency  $f$ , the energy flux can be written as

$$\phi_z = \frac{L_x L_y}{2\rho_0 c_0^2} \sum_{m,n=0}^{m_0, n_0} |A_{mn}|^2 c_g)_{mn} \varepsilon_{mn}, \quad (4.124)$$

where  $c_g)_{mn} = \frac{k_{zmn}}{k_0} c_0$  is the group velocity associated to the  $(m, n)^{\text{th}}$  mode.

This result highlights the fact that only propagative modes contribute to the energy flux.

Moreover, the energy  $E$  contained in the tube per unit length, defined by

$$E = \int_0^{L_x} dx \int_0^{L_y} dy \left[ \frac{\rho_0}{4} (v_x v_x^* + v_y v_y^* + v_z v_z^*) + \frac{1}{4\rho_0 c_0^2} pp^* \right], \quad (4.125)$$

can be written, considering the expressions of the particle velocity components

$$v_x = -\frac{i}{k_0 \rho_0 c_0} \sum_{m,n} \frac{m\pi}{L_x} A_{mn} \sin \frac{m\pi x}{L_x} \cos \frac{n\pi y}{L_y} e^{-ik_{zmn}z} e^{i\omega t}, \quad (4.126a)$$

$$v_y = -\frac{i}{k_0 \rho_0 c_0} \sum_{m,n} \frac{n\pi}{L_y} A_{mn} \cos \frac{m\pi x}{L_x} \sin \frac{n\pi y}{L_y} e^{-ik_{zmn}z} e^{i\omega t}, \quad (4.126b)$$

and, by virtue of the orthogonality of the modes (4.122), as

$$E = \frac{L_x L_y}{2\rho_0 c_0^2} \sum_{m,n} |A_{mn}|^2 \varepsilon_{mn}. \quad (4.127)$$

For each propagative mode, the ratio of the mean energy flux through the section of the guide (4.124) to the mean density of energy (4.127) is equal to the group velocity  $c_g)_{mn}$  that can be interpreted as the speed of propagation of the energy associated with the mode considered.

Note: if  $f < \min(f_{01}, f_{10})$ , then only the mode  $(0,0)$  is propagative; only one wave (i.e. the plane wave) is propagating along the main axis of the guide.

## 4.6. Problems of discontinuity in waveguides

### 4.6.1. Modal theory

By definition, a discontinuity in a waveguide is an abrupt change of the guide's characteristics along its main axis  $\vec{Oz}$ . Changes of cross-section (considered herein), of wall impedance, angle of curvature, etc. are all examples of discontinuity in a waveguide.

The considered problem focuses on the discontinuity of section (Figure 4.7). The origin of the  $z$ -axis is chosen in the plane of discontinuity, the index  $\ell = 1$  identifies the quantities relating to the guide upstream from the discontinuity ( $z < 0$ ) and  $\ell = 2$  those relating to the guide downstream from the discontinuity ( $z > 0$ ).

The notations  $u_\ell$  and  $w_\ell$  denote the transverse coordinates of each part of the guide ( $z < 0$  and  $z > 0$ ). For example,  $(u_\ell, w_\ell)$  denote the coordinates  $(x, y)$  for a guide of rectangular cross-section and  $(r, \theta)$  for a cylindrical guide (in relation to a cylindrical guide, the solution  $\psi(r, \theta)$  is given in section 5.1.4).

Each part of the guide is characterized by its geometry that is assumed to be compatible with a separation of the variables in Helmholtz's equation  $(\Delta + k^2)p = 0$ . Each wall is characterized by its uniform acoustic impedance. For each section of the guide, the problem presents an analogy with the problem (4.85), and consequently the acoustic field in the guide ( $\ell = 1, 2$ ) can be written as

$$p^{(\ell)}(u_\ell, w_\ell, z) = \sum_{mn} \left[ A_{mn}^{(\ell)} e^{-ik_{zmn}^{(\ell)} z} + B_{mn}^{(\ell)} e^{ik_{zmn}^{(\ell)} z} \right] \psi_{mn}^{(\ell)}(u_\ell, w_\ell). \quad (4.128)$$

The solutions  $\psi_{mn}^{(\ell)}(u_\ell, w_\ell)$  are assumed to be ortho-normal (orthogonal and normalized):

$$\iint dS_\ell \psi_{mn}^{(\ell)}(u_\ell, w_\ell) \psi_{\mu\nu}^{(\ell)}(u_\ell, w_\ell) = \delta_{m\mu} \delta_{n\nu}. \quad (4.129)$$

The solutions constitute an orthogonal basis (or quasi-orthogonal) for the section  $S_\ell$  (see Appendix).

The integration constants  $A_{mn}^{(\ell)}$  and  $B_{mn}^{(\ell)}$  can be obtained by writing:

– the equation of continuity on the pressure and particle velocity at the discontinuity:

$$p^{(1)}(u_1, w_1, 0) = p^{(2)}(u_2, w_2, 0), \quad (4.130)$$

$$\vec{v}^{(1)}(u_1, w_1, 0) = \vec{v}^{(2)}(u_2, w_2, 0), \quad (4.131)$$

– the equation of continuity at the end of each tube, which are of various forms depending of the system constituting the receiving ends of the guides. It is not the objective of this section to exploit of these conditions.

The equation of continuity on the pressure (4.130) can be written, substituting the appropriate form of solutions, as

$$\sum_{mn} [A_{mn}^{(1)} + B_{mn}^{(1)}] \psi_{mn}^{(1)}(u_1, w_1) = \sum_{\mu\nu} [A_{\mu\nu}^{(2)} + B_{\mu\nu}^{(2)}] \psi_{\mu\nu}^{(2)}(u_2, w_2). \quad (4.132)$$

Multiplying the left-hand side term by  $\psi_{m_0 n_0}^{(1)}(u_1, w_1)$  and integrating over the section of the tube (1) ( $S_1$  is assumed belonging to  $S_2$  at  $z = 0$ ) and considering the orthogonal characteristics of the solutions leads, for any mode  $(m_0, n_0)$ , to

$$A_{m_0 n_0}^{(1)} + B_{m_0 n_0}^{(1)} = \sum_{\mu\nu} [A_{\mu\nu}^{(2)} + B_{\mu\nu}^{(2)}] \iint_{S_1} \psi_{\mu\nu}^{(2)} \psi_{m_0 n_0}^{(1)} dS_1. \quad (4.133)$$

The equation of continuity applied to the  $z$ -component of the particle velocity at  $z = 0$ :

$$v_z^{(2)}(u_2, w_2, 0) = \begin{cases} v_z^{(1)}(u_1, w_1, 0) & \text{in } S_1, \\ 0 & \text{in } S_2 - S_1, \end{cases} \quad (4.134)$$

leads to the following system of equations:

$$k_{z\mu\nu}^{(2)} [A_{\mu\nu}^{(2)} - B_{\mu\nu}^{(2)}] = \sum_{mn} k_{zmn}^{(1)} [A_{mn}^{(1)} - B_{mn}^{(1)}] \iint_{S_1} \psi_{\mu\nu}^{(2)} \psi_{mn}^{(1)} dS_1 \quad (4.135)$$

The only purpose of the above developments is to show the approach adopted to solve the problems of guided propagation in the context of modal theory. These methods, very often used at low frequencies, become cost inefficient at high frequencies. The following section is a study case at very low frequencies of a situation that does not require great accuracy.

#### 4.6.2. Plane wave fields in waveguide with section discontinuities

As for the tube of rectangular section presented in section 4.5, cut-off frequencies are associated with each tube and with all modes  $(m, n)$ . For all frequencies lower than the first cut-off frequency, only the  $(0, 0)$  mode is



propagative, all the others being evanescent and therefore considered negligible as soon as the observation point is away from their sources.

In this context, as a first approximation, all waves, but the one associated with the (0,0) mode, are non-existent. The results of the previous section then lead to

$$\psi_{00}^{(\ell)} = 1/\sqrt{S_\ell}, \quad k_{z00}^{(\ell)} = k_0 = \omega/c_0, \quad (4.136)$$

and

$$p^{(\ell)} = \left[ A_{00}^{(\ell)} e^{-ik_0 z} + B_{00}^{(\ell)} e^{ik_0 z} \right] \psi_{00}^{(\ell)}, \quad \text{for each guide } \ell = 1, 2. \quad (4.137)$$

The equations of continuity applied at the discontinuity  $z=0$ , given by equations (4.133) and (4.135), lead, respectively, to the laws of continuity on pressure and on velocity flow:

$$\frac{A_{00}^{(1)}}{\sqrt{S_1}} + \frac{B_{00}^{(1)}}{\sqrt{S_1}} = \frac{A_{00}^{(2)}}{\sqrt{S_2}} + \frac{B_{00}^{(2)}}{\sqrt{S_2}} \quad \text{thus } p^{(1)}(z=0) = p^{(2)}(z=0), \quad (4.138)$$

$$S_2 \left[ \frac{A_{00}^{(2)}}{\sqrt{S_2}} - \frac{B_{00}^{(2)}}{\sqrt{S_2}} \right] = S_1 \left[ \frac{A_{00}^{(1)}}{\sqrt{S_1}} - \frac{B_{00}^{(1)}}{\sqrt{S_1}} \right]. \quad (4.139)$$

Equation (4.139) expresses, in this particular case, a continuity of the velocity flow at  $z=0$  (this is how this equation is usually introduced):

$$\left[ S_1 v_z^{(1)} \right]_{z=0_-} = \left[ S_2 v_z^{(2)} \right]_{z=0_+}. \quad (4.140)$$

Thus, equation (4.140) implies that the particle velocity presents a discontinuity similar to that of the section of the guide. In practice, perturbations are generated at the surface of the discontinuity (generation of modes of superior order  $m \neq 0$ ,  $n \neq 0$ ), but this domain can be considered localized (these modes are evanescent) and therefore, the wave conserves its plane characteristics at any point away from the discontinuity (zone which extend is denoted  $\delta$  in Figure 4.7) and at these points, the acoustic fields can be estimated using the equations of continuity (4.138) and (4.140).

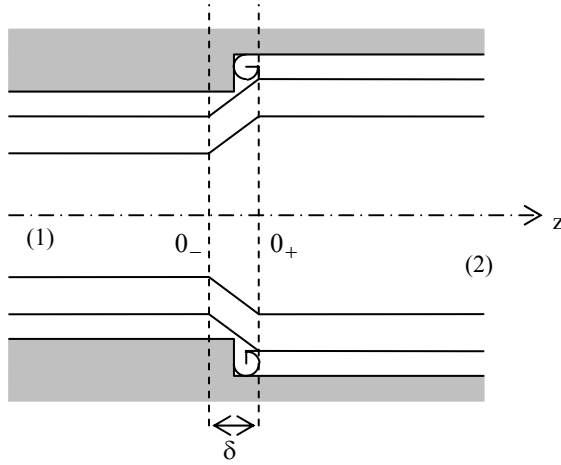

**Figure 4.7.** *Perturbation of the acoustic field at a discontinuity*

If there is no reflected wave in the medium (2) (infinite tube),  $B_{00}^{(2)} = 0$  and the coefficients of reflection and transmission at the discontinuity  $z = 0$  are written as

$$R = \frac{B_{00}^{(1)}}{A_{00}^{(1)}} = \frac{\zeta - 1}{\zeta + 1} \quad \text{and} \quad T = \sqrt{\frac{S_1}{S_2}} \frac{A_{00}^{(2)}}{A_{00}^{(1)}} = \frac{2\zeta}{\zeta + 1} \quad (4.141)$$

with  $\zeta = S_1 / S_2$ .

The law of conservation of energy then becomes

$$1 = R^2 + \frac{T^2}{\zeta}, \quad (4.142)$$

where the three factors represent, respectively, the incident energy flux (1), the reflected energy flux (R), and the transmitted energy flux ( $T^2 / \zeta$ ).

If  $S_2 \gg S_1$ , then  $\zeta \rightarrow 0$ ,  $\frac{T^2}{\zeta} = \frac{4\zeta}{(\zeta + 1)^2} \rightarrow 0$  and  $R \rightarrow -1$ . The energy is not

transmitted, but reflected. This important result shows that the energy flux transmitted outside the open tube is very small compared to the energy flux reflected at the extremity.

Note: at a “Y” joint (for example), considering the sign conventions of Figure 4.8. the previous results lead to

$$p_1 = p_2 = p_3, \text{ and } S_1 v_1 + S_2 v_2 + S_3 v_3 = 0,$$

thus

$$Y_1 + Y_2 + Y_3 = 0, \quad (4.143)$$

where  $Y_i = \frac{S_i v_i}{p_i}$  denotes the admittances presented at the junction of each guide.

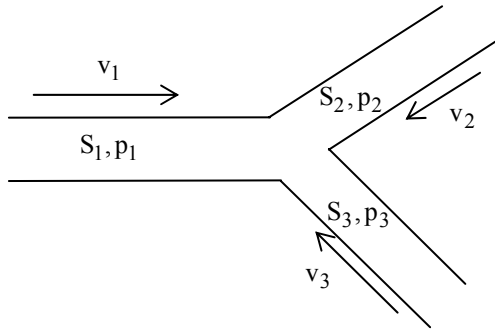

**Figure 4.8.** “Y” junction between three waveguides

## 4.7. Propagation in horns in non-dissipative fluids

### 4.7.1. Equation of horns

Seldom are the cases where a simple coordinate system can be adapted to a real horn so that the Helmholtz’s equation is separated into as many equations as separable variables. The few cases where this is possible are well known: the tubes with rectangular sections leading to simple equations in Cartesian coordinates (section 4.5), the tubes with circular sections leading to equations in cylindrical coordinates (see Chapter 5), the conical horns that can be treated in spherical coordinates (see Chapter 5), and the hyperbolic horns (not considered herein).

For the horns with more complex shapes (such as the exponential horn), there are no exact solutions, but only approximated ones, the most commonly used forms of which are presented here.

The shape of the horn influences the form of the solution. In the case of the conical horn with spherically symmetrical waves, it is clear that the surfaces of equal phase are spheres (no transverse modes). The coordinate  $r$  (Figure 4.9) is well suited to the description of such problem.

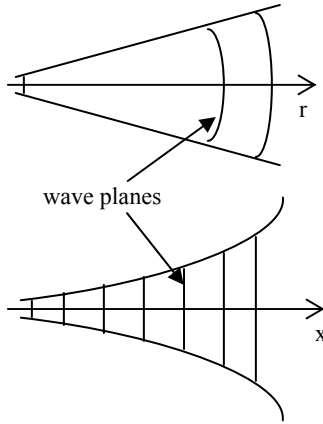

**Figure 4.9.** Conical and general horn shapes with wave planes

By extending this principle to any shape of horn, a theory with one parameter can lead to a satisfactory approximate solution while considering the equiphase surfaces plane. Actually, one can determine the degree of accuracy of such method, or the degree of approximation, due to these hypotheses. However, one should note that the above hypotheses imply that the variation of radius of the horn with respect to the coordinate  $x$  is not too steep and that the theory is only applicable at low frequencies. Therefore, the particle velocity is assumed along the  $\vec{O}x$  axis and the acoustic quantities depend only on  $x$  and  $t$ .

The substitution of equation (1.55) (reversible adiabatic transformation) into the equations of mass conservation (1.27) gives, away from the source,

$$\frac{1}{c_0^2} \iiint_{D_0} \frac{\partial p}{\partial t} dD_0 + \rho_0 \iint_{S_0} \bar{v} d\vec{S}_0 = 0,$$

where  $S_0$  is the surface delimiting the close space  $D_0$ . The expression of the fundamental laws in their integral form leads to an expression of one variable by considering the mean values of the transverse dimensions of the waveguide.

The integration over the volume and the surface of a section  $dx$  of horn yields:

$$\frac{1}{c_0^2} S dx \frac{\partial p}{\partial t} + \rho_0 [(Sv)_{x+dx} - (Sv)_x] = 0,$$

or

$$\frac{1}{c_0^2} S \frac{\partial p}{\partial t} + \rho_0 \frac{\partial}{\partial x} (Sv) = 0, \tag{4.144}$$

where  $v$  is the  $\vec{Ox}$  component of the particle velocity and where  $S$  depends only on the variable  $x$ .

Moreover, Euler's equation (1.33) taken away from any source:

$$\rho_0 \iiint_{D_0} \frac{\partial}{\partial t} \vec{v} dV + \iint_{S_0} p d\vec{S} = 0,$$

gives after a similar integration:

$$S dx \rho_0 \frac{\partial v}{\partial t} + [(p)_{x+dx} - (p)_x] (S)_x = 0,$$

the force  $(p)_{x+dx} [(S)_{x+dx} - (S)_x]$ , noted  $\vec{f}$  in Figure 4.10, is not exerted onto the section of fluid considered (reaction force from the walls of the horn).

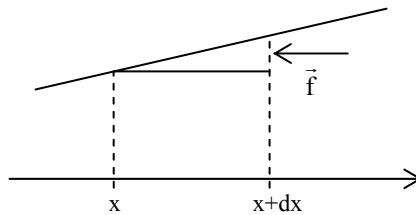

**Figure 4.10.** Element of fluid near the wall of the horn

The above equation yields finally the local Euler's equation:

$$\rho_0 \frac{\partial v}{\partial t} + \frac{\partial p}{\partial x} = 0. \tag{4.145}$$

By applying the operators  $\partial/\partial t$  to equation (4.144) and  $\partial/\partial x$  to equation (4.145), and taking the difference between the resulting expressions, leads to:

$$\frac{\partial^2 p}{\partial x^2} - \frac{1}{c_0^2} \frac{\partial^2 p}{\partial t^2} + \frac{1}{S} \frac{\partial S}{\partial x} \frac{\partial p}{\partial x} = 0,$$

$$\text{or } \frac{\partial^2 p}{\partial x^2} - \frac{1}{c_0^2} \frac{\partial^2 p}{\partial t^2} + \frac{\partial \ln S}{\partial x} \frac{\partial p}{\partial x} = 0. \tag{4.146}$$

The particle velocity can be calculated from the solution  $p$  into Euler's equation. The result is known as Webster's propagation equation (suggested first by Lagrange and Bernoulli).

The same result can also be obtained by considering the horn as a series of elementary cylindrical waveguides and applying the conditions presented in the previous paragraph at the interfaces between consecutive elementary tubes (Figure 4.11). Each elementary guide of length  $dx$  presents a discontinuity and a cylindrical tube in series. This combination of two well-known systems makes it possible to express the acoustic field at  $x + dx$  as a function of the field at  $x$ , in other words the variation of the field over a distance  $dx$ .

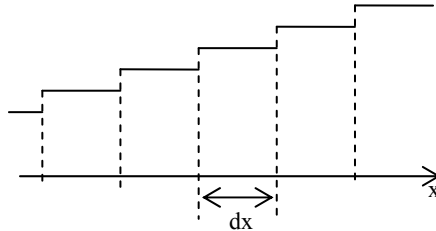

**Figure 4.11.** Series of discrete elementary cylindrical waveguide

The condition of continuity on the velocity flow (4.140) at the discontinuity can be written as  $vS = \text{constant}$  or  $\frac{dv}{v} = -\frac{dS}{S}$ . Consequently, the elementary variation of particle velocity in the  $\vec{O}x$  axis due to the discontinuity of cross-sectional area is

$$dv = -\frac{v}{S} \frac{dS}{dx} dx,$$

or, denoting  $\phi$  the velocity potential  $\left( v = \phi' = \frac{\partial \phi}{\partial x} \right)$ :

$$d\phi)_1 = -\frac{S'}{S} \phi' dx, \tag{4.147}$$

where the subscript “1” indicates that the elementary variation of  $\phi'$  is due to the discontinuity of cross-sectional area. The discontinuity is considered small so that  $d\phi'$  can be taken as an infinitely small number of first order and that consequently the value of  $\phi'$  in the right-hand side term is both its value before and after the discontinuity.

When considering a single elementary cylindrical waveguide of length  $dx$ , the equation of propagation within that guide given by

$$\phi'' = \frac{1}{c_0^2} \frac{\partial^2 \phi}{\partial t^2}$$

can be written, introducing the elementary variation of  $\phi'$  noted  $d\phi')_2$ , as

$$d\phi')_2 = \frac{1}{c_0^2} \frac{\partial^2 \phi}{\partial t^2} dx. \quad (4.148)$$

Thus the total variation  $d\phi'$  over the length  $dx$  is

$$d\phi' = d\phi')_1 + d\phi')_2 = \left[ -\frac{S'}{S} \phi' + \frac{1}{c_0^2} \frac{\partial^2 \phi}{\partial t^2} \right] dx,$$

$$\text{or } \phi'' + \frac{S'}{S} \phi' - c_0^{-2} \frac{\partial^2 \phi}{\partial t^2} = 0. \quad (4.149)$$

This equation is the same as (4.146) for the horn  $\left( p = -\rho_0 \frac{\partial \phi}{\partial t} \right)$ .

#### 4.7.2. Solutions for infinite exponential horns

By definition, an exponential horn is a horn, the cross-sectional area of which at the coordinate  $x$  is given by

$$S = S_0 e^{2\alpha x}.$$

Given the hypotheses made in the previous section, the solutions are of the form  $e^{\pm ikx} e^{i\omega t}$ . The substitution of these forms into the equation of propagation leads to the following equation of dispersion:

$$k^2 \mp 2i\alpha k - \frac{\omega^2}{c_0^2} = 0,$$

$$\text{or } k = \pm i\alpha \pm \sqrt{\frac{\omega^2}{c_0^2} - \alpha^2}, \quad (4.150)$$

the two  $\mp$  signs not necessarily being the same.

Consequently, the physical solutions to the problem, the converging ones, can be written as

$$e^{-\alpha x} e^{-i\sqrt{\frac{\omega^2}{c_0^2} - \alpha^2} x} e^{i\omega t}, \quad (4.151a)$$

$$e^{-\alpha x} e^{i\sqrt{\frac{\omega^2}{c_0^2} - \alpha^2} x} e^{i\omega t} \quad (4.151b)$$

The factor  $e^{-\alpha x}$  accounts for the variation of the wave amplitude due to the variation of the tube cross-section. These waves propagate in opposite directions with a phase velocity defined by

$$c_\phi = \frac{\omega}{\sqrt{\frac{\omega^2}{c_0^2} - \alpha^2}} = \frac{c_0}{\sqrt{1 - \left(\frac{f_c}{f}\right)^2}}, \quad (4.152)$$

where  $f_c = \frac{\alpha c_0}{2\pi}$  is the cut-off frequency of the guide, and with a group velocity equal to

$$c_g = \frac{\partial \omega}{\partial k} = c_0 \sqrt{1 - \left(\frac{f_c}{f}\right)^2}. \quad (4.153)$$

These velocities depend on the frequency, meaning that infinite horns are dispersive for sound waves. When the frequency coincides with the cut-off frequency  $f_c$ , the phase velocity tends to infinity. In other words, the fluid behaves with a unique phase across the entire length of the tube. However, no energy flux is associated with this type of phenomenon since the group velocity is null (equation (4.157)).



Below this limit, evanescent waves appear in the horn. Consequently, in order to transmit low frequencies, a horn requires a small value of  $\alpha$  ("slow aperture") and a great length. The expressions of intensity and energy density verify the latter condition. The acoustic intensity (energy flux) is given by

$$I = \frac{pp^*}{4\rho_0c_0} \left[ \left[ \left( \sqrt{1 - \left( \frac{f_c}{f} \right)^2} \right)^* + i \frac{f_c}{f} \right] + \left[ \sqrt{1 - \left( \frac{f_c}{f} \right)^2} - i \frac{f_c}{f} \right] \right],$$

$$I = \frac{pp^*}{4\rho_0c_0} \left[ \left( \sqrt{1 - \left( \frac{f_c}{f} \right)^2} \right)^* + \left( \sqrt{1 - \left( \frac{f_c}{f} \right)^2} \right) \right]. \quad (4.154)$$

Therefore:

$$\text{for } f \leq f_c, \quad I = 0,$$

$$\text{for } f > f_c, \quad I = \frac{e^{-2\alpha x}}{2\rho_0c_0} \sqrt{1 - \left( \frac{f_c}{f} \right)^2}. \quad (4.155)$$

The energy density is given by

$$E = \frac{\rho_0}{4} vv^* + \frac{pp^*}{4\rho_0c_0^2} = \frac{e^{-2\alpha x}}{2\rho_0c_0^2}, \quad (4.156)$$

and for  $f > f_c$ , the ratio of the intensity over the energy density is equal to the group velocity:

$$\frac{I}{E} = c_0 \sqrt{1 - \left( \frac{f_c}{f} \right)^2} = c_g, \quad (4.157)$$

interpreted as the speed of propagation of the energy in harmonic regime.

## Chapter 4: Appendix

# Eigenvalue Problems, Hilbert Space

In the two previous chapters, the notions of orthogonal functions, the basis of functions in which any solution of a given problem can be expanded, have been used several times and are extensively used in the following chapters. The objective of this Appendix is to present the associated formalities in order to simplify the developments to come. The mathematical notions introduced herein are simplified for the sake of clarity even though the rigorous reader would be advised to examine more detailed versions.

### A.1. Eigenvalue problems

#### A.1.1. *Properties of eigenfunctions and associated eigenvalues*

The governing equations, apart from the boundary conditions, are the equations of propagation of the waves and the Helmholtz equation. The latter can be deduced from the former when the objective is the analysis of the propagation of predetermined waves at given frequencies using harmonic solutions or, in case of unknown waves form, Fourier analysis. The homogeneous Helmholtz equation (equation of propagation in the frequency domain, without any source), in non-dissipative fluids, with which are associated certain boundary layers' conditions, constitute an eigenvalue problem. This problem has a solution  $\psi_p$  for each given value of the wavenumber  $k_p$  identified by the same subscript "p" that can take, depending on the problem at hand, a set of real, discrete or continuous values.

Let  $\psi$  be a class of continuous functions  $\psi_p$  with  $p \in \mathbb{N}$  with continuous first and second derivatives in the regular domain  $(D)$ , then  $\psi_p$  and  $\partial\psi_p/\partial n = \vec{n} \cdot \vec{\nabla}\psi_p$  ( $\vec{n}$  being the direction outward normal to the frontier of  $D$ ) are continuous across the surface  $(\partial D)$  and satisfy the following system of equations:

$$(\Delta - \lambda_p)\psi_p = 0 \text{ in } (D), \quad (4.158a)$$

$$\left(\zeta_0 - \frac{\partial}{\partial n}\right)\psi_p = 0 \text{ over } (\partial D). \quad (4.158b)$$

The complex parameter  $\zeta_0$  is, in acoustics, related to the impedance of the wall by the relation  $\zeta_0 = -ik_0\rho_0c_0/Z$ . This problem has a non-trivial solution  $\psi_p \neq 0$  only if the factors  $(\lambda_p)$  take certain well-defined values called eigenvalues (the functions  $\psi_p$  are then called eigenfunctions). Similarly, another class  $\Phi$  of functions  $\Phi_m$  is defined to satisfy, in the same domain  $(D)$ , a system of equations where the operators are the complex conjugates of those in equations (4.158a) and (4.158b):

$$(\Delta - \mu_m)\Phi_m = 0 \text{ in } (D), \quad (4.159a)$$

$$\left(\zeta_0^* - \frac{\partial}{\partial n}\right)\Phi_m = 0 \text{ over } (\partial D). \quad (4.159b)$$

The expression

$$\begin{aligned} & \iiint_{(D)} \left[ \Phi_m^* \Delta \psi_p - \psi_p (\Delta \Phi_m)^* \right] dD, \\ &= \iiint_{(D)} \text{div} \left[ \Phi_m^* \text{grad} \psi_p - \psi_p \text{grad} \Phi_m^* \right] dD, \\ &= \iint_{(\partial D)} \left[ \Phi_m^* \frac{\partial \psi_p}{\partial n} - \psi_p \frac{\partial \Phi_m^*}{\partial n} \right] dS, \end{aligned}$$

gives, taking into consideration the boundary conditions (4.158b) and (4.159b):

$$\iiint_{(D)} \left[ \Phi_m^* \Delta \psi_p - \psi_p (\Delta \Phi_m)^* \right] dD = \iint_{(\partial D)} \left[ \Phi_m^* \zeta_0 \psi_p - \psi_p \zeta_0 \Phi_m^* \right] dS = 0. \quad (4.160)$$

The substitution of equations (4.158a) and (4.159a) into the triple integral of equation (4.160) yields:

$$\iiint_{(D)} \left[ \Phi_m^* \Delta \psi_p - \psi_p (\Delta \Phi_m)^* \right] dD = (\lambda_p - \mu_m^*) \iint_{(\partial D)} \Phi_m^* \psi_p dD. \quad (4.161)$$

Equations (4.160) and (4.161) combined lead to the following result:

$$(\lambda_p - \mu_m^*) \iint_{(D)} \Phi_m^* \psi_p dD = 0. \quad (4.162)$$

Two situations can then occur, depending on the nature of the parameter  $\zeta_0$  (real or complex).

A.1.1.1. *The parameter  $\zeta_0$  is a real number*

The eigenvalue problems (4.158) and (4.159) are identical so that  $\Phi_p = \psi_p$  and  $\mu_p = \lambda_p$  and, according to (4.160):

$$\iiint_{(D)} [\psi_m^* \Delta \psi_p - \psi_p \Delta \psi_m^*] dD = 0, \quad \forall \psi_m, \psi_p \quad (4.163)$$

The Laplacian operator  $\Delta$  is said to be a Hermitian operator to the class of eigenfunctions in the domain  $(D)$  and the system:

$$(\Delta - \lambda_p) \psi_p = 0 \text{ in } (D), \quad (4.164a)$$

$$\left( \zeta_0 - \frac{\partial}{\partial n} \right) \psi_p = 0 \text{ over } (\partial D), \quad (4.164b)$$

is an auto-adjoint. Equation (4.162) then becomes:

$$0 = (\lambda_p - \lambda_m^*) \iiint_{(D)} \psi_m^* \psi_p dD, \quad \forall m, p,$$

implying that:

$$\text{if } m = p, \lambda_p = \lambda_p^* \text{ and the eigenvalues are real,} \quad (4.165)$$

$$\text{if } m \neq p, \iiint_{(D)} \psi_m^* \psi_p dD = 0 \text{ and the eigenfunctions are orthogonal.} \quad (4.166)$$

The fact that the eigenvalues are real implies that the eigenfunctions are also real (see equation (4.164a/b)). Therefore, by setting the norm of the eigenfunctions equal to the unit, equations (4.165) and (4.166) gives

$$\iiint_{(D)} \psi_m \psi_p dD = \delta_{mp}, \quad (4.167)$$

$$\lambda_m \in \mathfrak{R}, \quad (4.168)$$

which implies, when writing  $(-\lambda_m) = k_m^2$ , that the wavenumber  $k_m$  associated with the eigenvalue  $\lambda_m$  is either real or pure imaginary.

A.1.1.2. *The parameter  $\zeta_0$  is a complex number*

In this case, the conjugate of the eigenvalue problem (4.159a/b) is:

$$\Delta \Phi_m^* - \mu_m^* \Phi_m^* = 0 \text{ in } (D), \quad (4.169a)$$

$$\left( \zeta_0 - \frac{\partial}{\partial n} \right) \Phi_m^* = 0 \text{ over } (\partial D), \quad (4.169b)$$

leading, when compared to (4.158a/b), to:

$$\Phi_p^* = \psi_p \quad \text{and} \quad \mu_p^* = \lambda_p.$$

The operator is not a Hermitian operator and the system is not auto-adjoint anymore. Equation (4.162) then becomes:

$$(\lambda_p - \lambda_m) \iiint_{(D)} \psi_m \psi_p = 0, \quad \forall m, p, \quad (4.170)$$

implying that:

– if  $m = p$ , the equality is satisfied without conditions (the eigenvalues are generally complex),

– if  $m \neq p$ ,  $\iiint_{(D)} \psi^* \psi_p \, dD = 0$  and the eigenfunctions are orthogonal. (4.171)

A more complete analysis of the problem shows that qualifying the eigenfunctions as orthogonal is not correct from a rigorous mathematical point of view and that equation (4.171) is not satisfied exactly in the domain (D).

### A.1.2. Eigenvalue problems in acoustics

One can almost never overcome the above difficulties in acoustics since any wall, even perfectly rigid, is represented by a mixed boundary condition and that in many situations this condition cannot be replaced by Dirichlet's ( $\psi = 0$ ) or Neumann's conditions ( $\partial\psi/\partial n = 0$ ). In practice, however, the parameter  $\zeta_0$ , proportional to the admittance  $1/Z$  of the wall, is often a complex number with very small real and imaginary parts. Therefore, the properties of orthogonality (4.167) or (4.171) remain acceptable within the approximations made and the property (4.168) holds as a first approximation. The results (4.86) to (4.88b) obtained for waveguides, or those in equations (4.14) to (4.18), are all examples. The first presents a spectrum of discrete eigenvalues  $(m\pi/L_x)^2 + (n\pi/L_y)^2$  while the second presents a continuous spectrum of  $k_0$  values.

### A.1.3. Degeneracy

There is a “ $n^{\text{th}}$  order degeneracy” if there are  $n$  eigenfunctions associated with the same eigenvalue. If these eigenfunctions are not orthogonal once the problem is

solved, one can make them so by using appropriate linear combinations called the Schmidt's orthogonality process.

A simple example of degeneracy is the solution of the angular part of Helmholtz equation in generalized cylindrical coordinates (see Chapter 5). The equation

$$\frac{\partial^2 \psi}{\partial \varphi^2} + m^2 \psi = 0$$

has two linearly independent solutions associated with the same value of the positive (or null) quantum integer  $m$ , either  $e^{-im\varphi}$  and  $e^{+im\varphi}$  or  $\sin(m\varphi)$  and  $\cos(m\varphi)$ .

## A.2. Hilbert space

### A.2.1. Hilbert functions and $\mathcal{L}^2$ space

The previously defined functions  $\psi_m$  belong to the class of Hilbert functions, as shown by (4.167). Some remarks in the two previous chapters lead to the conclusion that these functions form a basis of functions in which the solution of "real" problems can be expanded. This section aims to detail this approach, using the results of section A.1 in the simplest way possible.

Since the functions  $\psi_m$  and solutions to acoustic problems belong to the  $\mathcal{L}^2$  space, it seems important to systematically study the mathematical properties of this space. The  $\mathcal{L}^2$  space is a space of infinite dimensions: a function  $\Phi$  (i.e. the velocity potential in acoustics for example) is defined by an infinity of "coordinates" that are the values taken by this function for various values of the variable ( $\vec{r}$ ). It happens that many well-known properties of a space of finite dimensions (i.e. 3-dimensional space) can easily be generalized to the  $\mathcal{L}^2$  space (such as the scalar product, the projection of a vector onto vector, the decomposition of a vector into an ortho-normal basis, etc.).

In geometry, it is often simpler to work with vectors rather than coordinates in a particular basis: it is the principle of vectorial calculus. A similar idea motivates the study of  $\mathcal{L}^2$  space. Each function of this space is considered as a vector of  $\mathcal{L}^2$ . The vector associated with a function  $\Phi$  is noted  $|\Phi\rangle$  (rather than  $\vec{\Phi}$ ) using Dirac's notation.

In acoustics, the complex conjugate  $\psi_m^*$  of the function  $\psi_m$  in equation (4.166) does not appear in the final relation (4.167) as a complex conjugate as it is always a real function. This situation is not common in physics and to keep the following remarks as general as possible, the complex conjugate notation will be conserved throughout.

The function  $\Phi$  is said to be of “summable square” if the integral

$$\iiint |\Phi(\vec{r})|^2 d\vec{r} \text{ is finite,} \quad (4.172)$$

and, since any linear combination of such function presents the same characteristics, the  $\mathcal{L}^2$  space is a vectorial space.

### A.2.2. Properties of Hilbert functions and complete discrete ortho-normal basis

The scalar product of a function  $\Phi_1$  by another function  $\Phi_2$  is defined by:

$$\langle \Phi_1 | \Phi_2 \rangle = \iiint \Phi_1^* \Phi_2 d\vec{r}. \quad (4.173)$$

It is called scalar product as it presents the usual characteristics of an “ordinary” scalar product (including the linearity), and particularly since  $\langle \Phi | \Phi \rangle$  is a positive real and two functions  $\Phi_1$  and  $\Phi_2$  are said to be orthogonal if  $\langle \Phi_1 | \Phi_2 \rangle = 0$ .

Considering a finite set of such functions identified by a subscript (i, j, etc.):

$$\psi_1, \psi_2, \dots, \psi_i, \text{ etc.}$$

one can qualify the set as ortho-normal if it satisfies equations (4.166) and (4.167), that is:

$$\langle \psi_i | \psi_j \rangle = \iiint \psi_i^* \psi_j d\vec{r} = \delta_{ij}, \quad (4.174)$$

where  $\delta_{ij}$  is the Kronecker  $\delta$ .

In addition, the set of functions is said to be complete if any function  $\Phi$  of the considered  $\mathcal{L}^2$  space can be written as the unique expansion in the basis of the functions  $\psi_i$ :

$$\Phi(\vec{r}) = \sum_i c_i \psi_i(\vec{r}). \quad (4.175)$$

The functions  $\psi_i$  form an ortho-normal, complete and discrete basis. The calculation of the coefficients  $c_i$  can be carried out by multiplying the two terms of equation (4.175) by  $\psi_j$  and by integrating over the whole domain (scalar product). When considering equation (4.174), the following is obtained:

$$c_j = \langle \psi_j | \Phi \rangle = \iiint \psi_j^* \Phi d\vec{r}. \quad (4.176)$$

The substitution of equation (4.176) (replacing the subscript “j” by “i”) into equation (4.175) gives, successively:

$$\begin{aligned}\Phi(\bar{r}) &= \sum_i \langle \psi_i | \Phi \rangle \psi_i(\bar{r}) = \sum_i \left[ \iiint \psi_i^* \Phi \, d\bar{r}' \right] \psi_i(\bar{r}), \\ &= \iiint \left[ \sum_i \psi_i^*(\bar{r}') \psi_i(\bar{r}) \right] \Phi(\bar{r}') \, d\bar{r}'.\end{aligned}$$

This result, compared with the definition of the Dirac distribution

$$\Phi(\bar{r}) = \iiint \delta(\bar{r} - \bar{r}') \Phi(\bar{r}') \, d\bar{r}',$$

leads immediately to (for any  $\Phi$ ):

$$\sum_i \psi_i^*(\bar{r}') \psi_i(\bar{r}) = \delta(\bar{r} - \bar{r}'). \quad (4.177)$$

This relation is known as “relation of closure” and expresses the completeness of the basis of  $\psi_i$  (as is the case for the sinuses functions used in section 4.5).

The scalar product of the function  $\Phi_1 = \sum_i b_i \psi_i$  by the function  $\Phi_2 = \sum_j c_j \psi_j$  is given by:

$$\langle \Phi_1 | \Phi_2 \rangle = \sum_{ij} b_i^* c_j \iiint \psi_i^* \psi_j \, d\bar{r} = \sum_{ij} b_i^* c_j \delta_{ij} = \sum_i b_i^* c_i, \quad (4.178)$$

and:

$$\langle \Phi_1 | \Phi_2 \rangle = \sum_i |c_i|^2. \quad (4.179)$$

The Fourier series is a well-known example.

### A.2.3. Continuous complete ortho-normal basis

A continuous set of functions identified by a subscript taking the continuous values  $(\alpha, \beta, \dots)$ , which satisfies the orthogonality condition:

$$\langle \psi_\alpha | \psi_\beta \rangle = \iiint \psi_\alpha^* \cdot \psi_\beta \, d\bar{r} = \delta(\alpha - \beta), \quad (4.180)$$

(where  $\delta$  is the Dirac distribution) as well as the relation of closure:

$$\int \psi_\alpha^*(\bar{r}') \psi_\alpha(\bar{r}) \, d\alpha = \delta(\bar{r}' - \bar{r}), \quad (4.181)$$



constitutes a basis of  $\mathcal{L}^2$  in which each function  $\Phi$  can be uniquely written in the form:

$$\Phi = \int d\alpha c_\alpha \psi_\alpha(\vec{r}) \tag{4.182}$$

where  $c_\alpha = \langle \psi_\alpha | \Phi \rangle = \iiint \psi_\alpha^*(\vec{r}) \Phi(\vec{r}) d\vec{r}$ . (4.183)

The Fourier integral is a well-known example of expansion in such basis; in this case equations (4.180) to (4.183) can be written, respectively, as:

$$\int_{-\infty}^{\infty} \frac{(e^{i\omega t})^*}{\sqrt{2\pi}} \frac{e^{i\omega' t}}{\sqrt{2\pi}} dt = \frac{1}{2\pi} \int_{-\infty}^{\infty} e^{i(\omega' - \omega)t} dt = \delta(\omega' - \omega), \tag{4.184}$$

$$\frac{1}{2\pi} \int_{-\infty}^{\infty} e^{-i\omega t'} e^{i\omega t} d\omega = \frac{1}{2\pi} \int_{-\infty}^{\infty} e^{i(t-t')\omega} d\omega = \delta(t' - t), \tag{4.185}$$

$$\Phi(t) = \frac{1}{\sqrt{2\pi}} \int_{-\infty}^{\infty} \tilde{\Phi}(\omega) e^{i\omega t} d\omega, \tag{4.186}$$

$$\tilde{\Phi}(\omega) = \frac{1}{\sqrt{2\pi}} \int_{-\infty}^{\infty} \Phi(t) e^{-i\omega t} dt. \tag{4.187}$$

Note 1: the function  $e^{i\omega t}$  is of course not a vector of  $\mathcal{L}^2$ ! However, the previous properties can still be applied to it. This is not much of a problem as in practice these functions are always truncated (integrating in the time domain between  $-\infty$  and  $+\infty$  does not come in useful since the dissipation is not negligible in practice) and therefore satisfy all the properties of a vector of  $\mathcal{L}^2$ .

Note 2: the use of the Dirac notation makes possible the use of a condensed and lighter presentation. The following are illustrations of its benefits. The scalar product of ortho-normal functions (equations (4.174) and (4.180)) is written:

$$\langle \psi_i | \psi_j \rangle = \delta_{ij}. \tag{4.188}$$

The expansion in a basis of ortho-normal functions (4.175) and (4.182) can be written as:

$$|\Phi\rangle = \sum_i c_i |\psi_i\rangle,$$

or, according to (4.176) and (4.183):

$$|\Phi\rangle = \sum_i \langle \psi_i | \Phi \rangle |\psi_i\rangle \text{ or } |\Phi\rangle = \sum_i |\psi_i\rangle \langle \psi_i | \Phi \rangle, \tag{4.189}$$

which leads directly to the relation of closure (4.177) and (4.181):

$$1 = \sum_i |\psi_i\rangle \langle \psi_i|, \tag{4.190}$$

where, according to the statement in section A.2.1 that  $|\Phi\rangle$  is a vector of  $\mathcal{L}^2$ , the projection  $\langle \vec{r} | \Phi \rangle$  of which onto the direction  $|\vec{r}\rangle$  represents the function  $\Phi(\vec{r})$ ,

$$\langle \vec{r}' | \vec{r} \rangle = \sum_i \langle \vec{r}' | \psi_i \rangle \langle \psi_i | \vec{r} \rangle, \quad (4.191)$$

$$\text{or } \delta(\vec{r}' - \vec{r}) = \sum_i \psi_i^*(\vec{r}) \psi_i(\vec{r}'). \quad (4.192)$$

Note 3: the equality between two expansions in the same basis,

$$\sum_i a_i |\psi_i\rangle = \sum_j b_j |\psi_j\rangle \quad (4.193)$$

is equivalent to the equality of the coefficients of equal subscripts, and subsequently to the equality, term by term, of the expansion coefficients:

$$a_m = b_m.$$

Proof of this is given by projecting each term of equation (4.193), using the scalar product (4.173) and (4.180), onto the eigenvectors of the basis:

$$\langle \psi_m | \sum_i a_i |\psi_i\rangle = \langle \psi_m | \sum_i b_i |\psi_j\rangle,$$

and applying the relation of orthogonality  $\langle \psi_m | \psi_n \rangle = \delta_{mn}$ . Thus:

$$\sum_i a_i \delta_{im} = \sum_j b_j \delta_{jm} \text{ or } a_m = b_m.$$

*This page intentionally left blank*

## Chapter 5

# Basic Solutions to the Equations of Linear Propagation in Cylindrical and Spherical Coordinates

This chapter complements the previous one by providing a comprehensive description of the acoustic motion in fluids initially at rest in the assumption of linear acoustics. The problems and general solutions are presented in curvilinear, cylindrical and spherical coordinate systems. Dissipation is considered, where appropriate, in a similar fashion to that in Chapter 4.

### **5.1. Basic solutions to the equations of linear propagation in cylindrical coordinates**

#### ***5.1.1. General solution to the wave equation***

The polar coordinates  $(r, \varphi)$  and the coordinate  $z$  constitute the coordinate system. The corresponding unit vectors are respectively denoted  $\vec{e}_r$ ,  $\vec{e}_\varphi$  and  $\vec{e}_z$ .

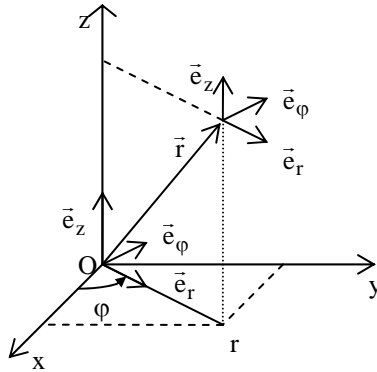

**Figure 5.1.** *Cylindrical coordinate system*

The usual operators take the following forms:

$$d\vec{r} = dr \vec{e}_r + r d\varphi \vec{e}_\varphi + dz \vec{e}_z, \quad (5.1)$$

$$\text{grad}U = \frac{\partial U}{\partial r} \vec{e}_r + \frac{1}{r} \frac{\partial U}{\partial \varphi} \vec{e}_\varphi + \frac{\partial U}{\partial z} \vec{e}_z, \quad (5.2)$$

$$\text{div} \vec{A} = \frac{1}{r} \frac{\partial}{\partial r} (r A_r) + \frac{1}{r} \frac{\partial A_\varphi}{\partial \varphi} + \frac{\partial A_z}{\partial z}, \quad (5.3)$$

$$\text{rot} \vec{A} = \left[ \frac{1}{r} \frac{\partial A_z}{\partial \varphi} - \frac{\partial A_\varphi}{\partial z} \right] \vec{e}_r + \left[ \frac{\partial A_r}{\partial z} - \frac{\partial A_z}{\partial r} \right] \vec{e}_\varphi + \left[ \frac{1}{r} \frac{\partial}{\partial r} (r A_\varphi) - \frac{1}{r} \frac{\partial A_r}{\partial \varphi} \right] \vec{e}_z, \quad (5.4)$$

$$\Delta U = \text{div grad}U = \frac{\partial^2 U}{\partial r^2} + \frac{1}{r} \frac{\partial U}{\partial r} + \frac{1}{r^2} \frac{\partial^2 U}{\partial \varphi^2} + \frac{\partial^2 U}{\partial z^2}, \quad (5.5)$$

$$\Delta \vec{A} = \text{grad div} \vec{A} - \text{rot rot} \vec{A}. \quad (5.6)$$

Away from any source, the acoustic pressure satisfies the following equation of propagation:

$$\nabla^2 p = \left[ \frac{1}{r} \frac{\partial}{\partial r} \left( r \frac{\partial}{\partial r} \right) + \frac{1}{r^2} \frac{\partial^2}{\partial \varphi^2} + \frac{\partial^2}{\partial z^2} - \frac{1}{c^2} \frac{\partial^2}{\partial t^2} \right] p = 0. \quad (5.7)$$

The solutions to this equation are assumed to be separable and in the form

$$R(r)\Phi(\varphi)Z(z)T(t). \quad (5.8)$$

By using the same approach as in section 4.2.2, equations (4.24) to (4.31) and, applying the same logic, the substitution of solution (5.8) into equation (5.7) leads consecutively to

$$\frac{1}{R} \frac{d^2 R}{dr^2} + \frac{1}{rR} \frac{dR}{dr} + \frac{1}{r^2 \Phi} \frac{d^2 \Phi}{d\varphi^2} + \frac{1}{Z} \frac{d^2 Z}{dz^2} = \frac{1}{c^2 T} \frac{d^2 T}{dt^2} = -k^2,$$

$$\text{or } \frac{d^2 T}{dt^2} + \omega^2 T = 0 \text{ with } \omega^2 = k^2 c^2, \quad (5.9)$$

$$\text{and } \frac{1}{R} \frac{d^2 R}{dr^2} + \frac{1}{rR} \frac{dR}{dr} + \frac{1}{r^2 \Phi} \frac{d^2 \Phi}{d\varphi^2} + k^2 = -\frac{1}{Z} \frac{d^2 Z}{dz^2} = k_z^2,$$

$$\text{thus to } \frac{d^2 Z}{dz^2} + k_z^2 Z = 0 \quad (5.10)$$

$$\text{and } \frac{r^2}{R} \left( \frac{d^2}{dr^2} + \frac{1}{r} \frac{d}{dr} \right) R + (k^2 - k_z^2) r^2 = -\frac{1}{\Phi} \frac{d^2 \Phi}{d\varphi^2} = m^2,$$

and finally to

$$\frac{1}{r^2} \frac{d^2 \Phi}{d\varphi^2} + k_\varphi^2 \Phi = 0 \text{ with } k_\varphi(r) = \frac{m}{r} \text{ or } \frac{d^2 \Phi}{d\varphi^2} + m^2 \Phi = 0, \quad (5.11)$$

and

$$\left( \frac{d^2}{dr^2} + \frac{1}{r} \frac{d}{dr} \right) R + k_r^2(r) R = 0, \quad (5.12)$$

where

$$k_r^2(r) = k^2 - k_z^2 - k_\varphi^2(r) \quad (5.13)$$

is the associated equation of dispersion  $k^2 = k_r^2(r) + k_\varphi^2(r) + k_z^2$ .

The in-plane “wavenumber component” defined by the polar coordinates and denoted here as  $k_w$  is independent of the variable  $r$  and is given by

$$k_w^2 = k^2 - k_z^2 = k_r^2(r) + k_\varphi^2(r), \quad (5.14)$$

where the three “components”  $k_r$ ,  $k_\phi$  and  $k_z$  of the wavenumber  $\vec{k}$  are always functions of the quantum number  $m$  (unlike the wavenumber  $\vec{k}$  itself).

By adopting this notation, the radial equation (5.12) takes the form called “cylindrical Bessel’s equation”:

$$\left( \frac{d^2}{dr^2} + \frac{1}{r} \frac{d}{dr} \right) R(r) + \left( k_w^2 - \frac{m^2}{r^2} \right) R(r) = 0. \quad (5.15)$$

The general solutions to equations (5.9), (5.10), (5.11) and (5.12) (or 5.15) are respectively

$$T = e^{i\omega t} \quad (\text{see the note on equation (4.26)}),$$

$$Z = A_1 \cos(k_z z) + B_1 \sin(k_z z),$$

$$\text{or } Z = A_2 \cos(k_z z + \phi_z), \quad (5.16)$$

$$\text{or } Z = B_2 \sin(k_z z + \phi_z),$$

$$\text{or finally } Z = \alpha_1 e^{ik_z z} + \beta_1 e^{-ik_z z}. \quad (5.17)$$

$\Phi$  presents the same form of solution as  $Z$ , except that  $(k_z z)$  is replaced by  $(m\phi)$  where the index  $m$  is an integer so that the function  $\Phi$  is periodic of period  $2\pi$ .

$$R = A_{1m} J_m(k_w r) + A_{2m} N_m(k_w r),$$

$$\text{or } R = B_{1m} H_m^+(k_w r) + B_{2m} H_m^-(k_w r). \quad (5.18)$$

The general solution to equation (5.7) is a linear combination (sum over the index  $m$  and integration over the coefficient  $k_w$ ) of the solutions (5.8) that depend on these factors and constitute a base of the considered space (see the Appendix to Chapter 4). An example of such expansion, called Fourier-Bessel, is given by equation (3.53) or (5.37).

The solutions (5.18) are respectively Bessel’s functions of the 1<sup>st</sup> kind expanded to the  $m^{\text{th}}$  order ( $J_m$ ), of the 2<sup>nd</sup> kind (also called cylindrical Neumann’s functions) and finally cylindrical Hankel’s functions, qualified as convergent ( $H_m^+$ ) or divergent ( $H_m^-$ ) depending on the choice of  $e^{i\omega t}$ . Since Neumann’s functions diverge at the origin, they cannot appear in the solutions if the considered domain includes the origin of the coordinate system.

Even though they are only approximations, the asymptotic expressions of Bessel and Hankel's functions reveal the general behavior of these functions. For  $x > m \geq 1$  (and for  $x \gg 1$  if  $m = 0$ ), these asymptotic expressions can be written as

$$J_m(x) = \sqrt{\frac{2}{\pi x}} \cos \left[ x - (2m+1)\frac{\pi}{4} \right], \quad (5.19)$$

$$N_m(x) = \sqrt{\frac{2}{\pi x}} \sin \left[ x - (2m+1)\frac{\pi}{4} \right], \quad (5.20)$$

$$H_m^+(x) = \sqrt{\frac{2}{\pi x}} e^{i \left[ x - (2m+1)\frac{\pi}{4} \right]}, \quad (5.21)$$

$$H_m^-(x) = \sqrt{\frac{2}{\pi x}} e^{-i \left[ x - (2m+1)\frac{\pi}{4} \right]}. \quad (5.22)$$

These forms highlight the stationary characteristics of the waves described by Bessel's functions and the propagative characteristics of the those described by Hankel's functions (diverging for  $H_m^-$  and converging for  $H_m^+$ ). All present an asymptotic "geometrical" decrease in the form  $1/\sqrt{r}$  that is typical of cylindrical waves.

### 5.1.2. Progressive cylindrical waves: radiation from an infinitely long cylinder in harmonic regime

#### 5.1.2.1. A general case

A vibrating infinite cylinder of radius  $R$  and of main axis  $\bar{O}z$  radiates in an infinite domain of fluid at rest. Its motion is described by the harmonic radial vibration velocity of its surface as

$$v_r(r = R) = v_0 \cos(k_z z) \cos(m_0 \varphi) e^{i\omega t}. \quad (5.23)$$



The problem can then be written as

$$\left[ \frac{1}{r} \frac{\partial}{\partial r} \left( r \frac{\partial}{\partial r} \right) + \frac{1}{r^2} \frac{\partial^2}{\partial \varphi^2} + \frac{\partial^2}{\partial z^2} + k^2 \right] p = 0, \quad r > R, \quad (5.24a)$$

$$\begin{cases} \frac{i}{k_0 c_0 \rho_0} \frac{\partial p}{\partial r} = v_0 \cos(k_z z) \cos(m_0 \varphi) e^{i\omega t}, & r = R, \\ \text{Sommerfeld's condition at infinity} \\ \text{(no back-propagation wave).} \end{cases} \quad (5.24b)$$

The solution is unique and written as

$$p = \frac{-ik_0 c_0 \rho_0 v_0}{\partial H_{m_0}^-(k_w R) / \partial R} H_{m_0}^-(k_w r) \cos(k_z z) \cos(m_0 \varphi) e^{i\omega t}, \quad (5.25)$$

### 5.1.2.2. First order oscillator: oscillating cylinder and vibrating string

The oscillating cylinder is generally characterized by a vibration velocity (equation (5.23) with  $m_0 = 1$ ) in the form

$$v_r(r = R) = v_0 \cos(k_z z) \cos \varphi e^{i\omega t}. \quad (5.26)$$

The solution is given by equation (5.25) where  $m_0 = 1$ .

In the particular case where the radius  $R$  is significantly smaller than the wavelength considered ( $k_w R \ll 1$ ), as is the case of a “vibrating string”:

$$H_1^-(k_w R) \approx \frac{2i}{\pi k_w R},$$

and the solution can be approximated by

$$p \approx \frac{\pi}{2} \rho_0 c_0 v_0 k_0 k_w R^2 H_1^-(k_w r) \cos(k_z z) \cos(\varphi) e^{i\omega t}, \quad (5.27)$$

which asymptotic expression, obtained considering the far field ( $k_w r \rightarrow \infty$ ), is

$$p = \rho_0 c_0 v_0 k_0 R \sqrt{\frac{\pi}{2} k_w R} \sqrt{\frac{R}{r}} e^{-i \left( k_w r - \frac{3\pi}{4} \right)} \cos(k_z z) \cos(\varphi) e^{i\omega t} \quad (5.28)$$

The amplitude of the acoustic field is proportional to  $\frac{k_0 \sqrt{k_w}}{\sqrt{r}} R^2$  and is extremely small. Consequently, the acoustic energy radiated by a vibrating string is usually negligible.

### 5.1.2.3. Pulsating oscillator: cylindrical monopole – elementary solution

As a vibrator of order zero ( $m_0 = 0$ ), the pulsating cylinder is characterized by the vibration velocity

$$v_r(r = R) = v_0 \cos(k_z z) e^{i\omega t}. \quad (5.29)$$

The solution (5.25) can be used in this case by taking  $m_0 = 0$ . In the particular case where the radius of the cylinder is small compared to the wavelength ( $k_w R \ll 1$ ):

$$\frac{\partial H_0^-(k_w R)}{\partial R} = -k_w H_1^-(k_w R) \approx \frac{-2i}{\pi R}, \quad (5.30)$$

and consequently the solution takes the following form:

$$p \approx \frac{1}{4} k_0 \rho_0 c_0 Q_0 H_0^-(k_w r) \cos(k_z z) e^{i\omega t}, \quad (5.31)$$

where the factor  $Q_0$  denotes the amplitude of the lineic surface velocity ( $Q_0 = 2\pi R v_0$ ).

The near-field solution ( $k_w r \ll 1$ ) can be written as

$$p \approx \frac{1}{4} k_0 \rho_0 c_0 Q_0 \left[ 1 + i \frac{2}{\pi} \ln \left( \frac{2}{e k_w r} \right) \right] \cos(k_z z) e^{i\omega t}, \quad (5.32)$$

where  $e = 1.78$  denotes Euler's constant. The far field from the cylindrical monopole can be written in the following form:

$$p \approx \frac{1}{4} k_0 \rho_0 c_0 Q_0 \sqrt{\frac{2}{\pi k_w r}} e^{-i \left( k_w r - \frac{\pi}{4} \right)} \cos(k_z z) e^{i\omega t}. \quad (5.33)$$

The emitted sound power  $\mathcal{P}$  at the coordinate  $z$ , per unit of length, is obtained by calculating the energy flux through a cylinder of unit height, undefined radius

and centered on the axis  $\vec{Oz}$  (conservation of the energy flux). For the sake of simplicity and choosing the radius  $r$  tending to infinity, the asymptotic solution (5.33) becomes

$$\mathcal{P} = \lim_{r \rightarrow \infty} \frac{2\pi r}{k_0 \rho_0 c_0} \frac{1}{4} \left[ p \left( i \frac{\partial p}{\partial r} \right)^* + p^* \left( i \frac{\partial p}{\partial r} \right) \right], \quad (5.34)$$

and finally

$$\mathcal{P} = \frac{1}{8} k_0 \rho_0 c_0 Q_0^2 \cos^2(k_z z). \quad (5.35)$$

Note: according to the relation  $p = -\rho_0 \partial \phi / \partial t$  (1.67) and to the definition of the Green's function  $G = -\phi$  associated with the unit volume velocity of the source, independent of  $z$  ( $\cos(k_z z) = 1, k_z = 0$ ) and with a very small radius, the two-dimensional Green's function in the frequency domain must be written as

$$G = \frac{p}{k_0 \rho_0 c_0 Q_0}, \quad (5.36a)$$

thus, according to (5.31):

$$G = -\frac{i}{4} H_0^-(k_w r), \quad (5.36b)$$

or, since  $k_z = 0$  ( $k = k_w$ ),

$$G = -\frac{i}{4} H_0^-(kr).$$

This result is in accordance with equation (3.50).

It is important to note that other developments of  $H_0^-$  than the one given by equation (3.53) are used in other works and among which one will find

$$\begin{aligned} H_0^-(k|\vec{r} - \vec{r}_0|) &= \frac{i}{\pi^2} \sum_{m=0}^{\infty} (2 - \delta_{m0}) \cos[m(\varphi - \varphi_0)] \\ &\times \int_{-\infty}^{+\infty} \frac{J_m(\chi_m r) J_m(\chi_m r_0)}{\chi_m^2 - k^2} \chi_m d\chi_m, \end{aligned} \quad (5.37a)$$

$$H_0^-(k|\vec{r}-\vec{r}_0|) = \sum_{m=-\infty}^{\infty} e^{im(\varphi-\varphi_0)} J_m(kr_<) H_m(kr_>), \tag{5.37b}$$

$$H_0^-(k|\vec{r}-\vec{r}_0|) = \sum_{m=0}^{\infty} (2-\delta_{m0}) \cos[m(\varphi-\varphi_0)] J_m(kr_<) H_m(kr_>), \tag{5.37c}$$

where  $r_< = \min(r, r_0)$  and  $r_> = \max(r, r_0)$ .

5.1.2.4. Two out of phase pulsating cylinders: the cylindrical dipole

Two out of phase pulsating cylinders of same radius (very small,  $k_w R \ll 1$ ), of principal axes parallel to  $\vec{Oz}$  and intercepting the  $\vec{Ox}$  axis at respectively  $x_0$  and  $x_0 + dx_0$ , radiate in an infinite domain with the same amplitude of volume velocity  $Q_0$  (Figure 5.2).

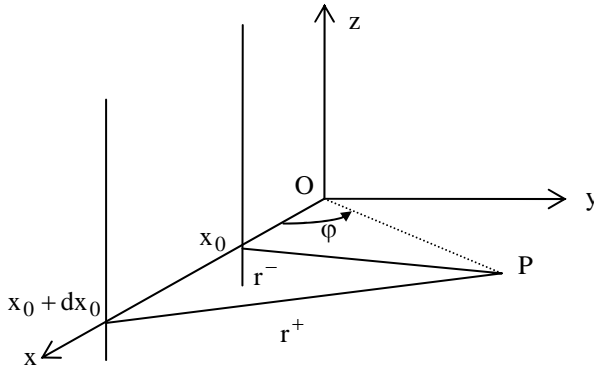

Figure 5.2. Cylindrical dipole

The amplitude of the acoustic pressure at the point P,

$$p = \frac{1}{4} k_0 \rho_0 c_0 Q_0 \cos(k_z z) \left[ H_0^-(k_w r^+) - H_0^-(k_w r^-) \right] \tag{5.38a}$$

can be written, if the point P is significantly far from the dipole, as

$$p = \frac{1}{4} k_0 \rho_0 c_0 Q_0 \cos(k_z z) \frac{\partial H_0^-(k_w r)}{\partial x_0} dx_0. \tag{5.38b}$$

Since  $r = \sqrt{(x-x_0)^2 + (y-y_0)^2}$ ,

$$\frac{\partial}{\partial x_0} H_0^- = \frac{\partial H_0^-}{\partial r} \frac{\partial r}{\partial x_0} = [-k_w H_1^-(k_w r)] \left[ -\frac{x-x_0}{r} \right] = k_w H_1^-(k_w r) \cos \varphi,$$

and the expression of the amplitude becomes

$$p = \rho_0 c_0 Q_0 dx_0 \frac{k_0 k_w}{4} H_1^-(k_w r) \cos(k_z z) \cos \varphi. \tag{5.39}$$

The comparison of this expression with (equation (5.28)) of the oscillating cylinder shows that the dipole and the oscillating cylinder present the same behavior. A lineic underwater source, for example, presents dipolar characteristics since the image source with respect to the water surface is out of phase (phase shift of  $\pi$  at the reflection water-air; see section 4.4.4).

**5.1.3. Diffraction of a plane wave by a cylinder characterized by a surface impedance**

An infinite cylinder of axis  $\vec{O}z$  is characterized by its acoustic wall impedance  $Z_a$ . A harmonic plane wave traveling in the negative x-direction is diffracted by the cylinder (Figure 5.3).

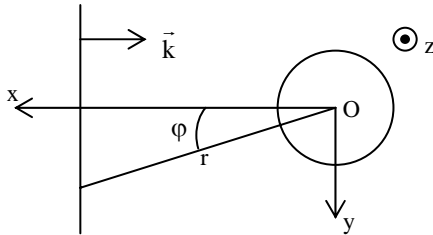

**Figure 5.3.** Diffraction of an incident plane wave by an infinite cylinder

The problem can be written as follows:

$$\left\{ \begin{array}{l} \left[ \frac{1}{r} \frac{\partial}{\partial r} \left( r \frac{\partial}{\partial r} \right) + \frac{1}{r^2} \frac{\partial^2}{\partial \varphi^2} + \frac{\partial^2}{\partial z^2} + k^2 \right] p = 0, \quad r > R, \\ \frac{i}{k_0 \rho_0 c_0} \frac{\partial p}{\partial r} = \frac{-1}{Z_a} p, \quad r = R, \\ \text{Sommerfeld's condition at infinity,} \\ \text{harmonic incident plane wave } p_i = P_0 e^{i k r \cos(\varphi)} e^{i \omega t}. \end{array} \right. \tag{5.40}$$

In order to treat the problem in the cylindrical coordinate system  $(r, \varphi, z)$  centered on the axis of the cylinder, the incident plane wave is assumed to be the superposition of cylindrical waves (the solutions of the Helmholtz operator constitute a base of the considered space):

$$\begin{aligned} p_i &= P_0 e^{i k r \cos \varphi} e^{i \omega t}, \\ &= P_0 \sum_{m=0}^{\infty} (2 - \delta_{m0}) i^m \cos(m\varphi) J_m(kr) e^{i \omega t}, \end{aligned} \quad (5.41)$$

where  $k_w = k$  since the incident wave is independent of the variable  $z$  ( $k_z = 0$ ).

The diffracted wave is sought as a divergent cylindrical wave, independent of  $z$  (as  $p_i$  is), expanded on the basis of admissible functions that satisfy the same criteria as the solution

$$p_r = P_0 \sum_{n=0}^{\infty} A_n H_n^-(kr) \cos(n\varphi) e^{i \omega t}. \quad (5.42)$$

The coefficients  $A_n$  are obtained using the boundary conditions of the problem (5.40):

$$\frac{i}{k_0 \rho_0 c_0} \frac{\partial}{\partial r} (p_i + p_r) = \frac{-1}{Z_a} (p_i + p_r), \quad r = R,$$

thus identifying the terms of the series of each equation,

$$\begin{aligned} \frac{i}{k_0 \rho_0 c_0} \left[ k A_n \frac{dH_n^-(kR)}{d(kR)} + (2 - \delta_{n0}) i^n k \frac{dJ_n(kR)}{d(kR)} \right] \\ = \frac{-1}{Z_a} \left[ A_n H_n^-(kR) + (2 - \delta_{n0}) i^n J_n(kR) \right]. \end{aligned}$$

Consequently, since  $k \approx k_0$  and denoting  $\beta_a = \rho_0 c_0 / Z_a$ ,

$$A_n = \frac{-(2 - \delta_{n0}) i^n}{i H_n'(kR) + \beta_a H_n^-(kR)} \left[ i J_n'(kR) + \beta_a J_n(kR) \right]. \quad (5.43)$$

This result shows that the amplitude of the diffracted wave tends to zero at low frequencies (where the incident wavelength is far greater than the radius of the

cylinder). Inversely, the energy diffracted at high frequencies is of similar magnitude to the incident wave, and the directivity factor presents important angular variations.

**5.1.4. Propagation of harmonic waves in cylindrical waveguides**

5.1.4.1. *Governing equation and general solution*

A column of fluid contained in an infinite tube with a circular section of radius  $R$  is the medium of propagation of a harmonic acoustic field generated upstream and propagating along the axis of the tube. The local reaction of the walls of the guide (assumed perfectly rigid) is modeled by the acoustic specific admittance  $\beta_a$  (equation (3.10)) introducing the boundary layers effects. The dissipation introduced by the wavenumber  $k_a$  in equation (2.86) remains negligible when compared to the dissipation due to the boundary layers.

The problem can be written as follows:

$$\left\{ \begin{array}{l} \left[ \frac{1}{r} \frac{\partial}{\partial r} \left( r \frac{\partial}{\partial r} \right) + \frac{1}{r^2} \frac{\partial^2}{\partial \phi^2} + \frac{\partial^2}{\partial z^2} + k_0^2 \right] p = 0, \quad r < R, \quad z > z_s, \\ \frac{\partial p}{\partial r} = -ik_0 \beta_a p, \quad r = R, \\ p \text{ remains finite at } r = 0, \\ \text{the harmonic wave } e^{i\omega t} \text{ generated upstream (at } z = z_s) \\ \text{propagates in the positive } z\text{-direction (no reflected wave),} \\ \beta_a = \frac{1+i}{\sqrt{2}} \sqrt{k_0} \left[ \left( 1 - \frac{k_{0r}^2}{k_0^2} \right) \sqrt{\ell'_v} + (\gamma - 1) \sqrt{\ell_h} \right] \quad (3.10). \end{array} \right. \quad (5.44)$$

The condition on  $p$  (finite at  $r = 0$ ) is a boundary condition over a cylinder the radius of which tends to zero. It implies than Neumann’s function cannot appear in the solution as it diverges at the origin. The general solution to the problem can be written (the time factor is suppressed throughout) as

$$p = \sum_{m=0}^{\infty} \sum_{v=0}^{\infty} [A_{mv} \cos(m\phi) + B_{mv} \sin(m\phi)] J_m(k_{wmv} r) e^{-ik_{zmv} z}, \quad (5.45)$$

where the presence of the quantum number  $v$  is explained in the following section.

In presence of a reflected wave, the factor  $e^{-ik_{zmv}z}$  would be replaced by  $e^{-ik_{zmv}z} + R_{mv}e^{+ik_{zmv}z}$  where  $R_{mv}$  denotes the reflection coefficient for the  $(m, v)^{\text{th}}$  mode.

The boundary condition at  $r = R$  leads, by identification term by term, to

$$k_{wmv} J'_m(k_{wmv}R) = -ik_0 \beta_a J_m(k_{wmv}R). \quad (5.46a)$$

Solving this equation results in complex eigenvalues  $k_{wmv}$ . The integration constants  $A_{mv}$  and  $B_{mv}$  are imposed by the properties of the guide at any  $z < z_s$  and particularly those of the source. This type of problem is considered in Chapter 6 on integral formalism).

#### 5.1.4.2. Approximated eigenvalues (Neumann's boundary conditions, $\beta_a \approx 0$ )

In the (common) cases where the wall admittance of the tube can be ignored ( $\beta_a \approx 0$ ), the condition (5.46a) becomes

$$k_{wmv}^{(0)} = \gamma_{mv} / R, \quad (5.46b)$$

where  $\gamma_{mv}$  ( $v = 0, 1, 2, \text{etc.}$ ) denotes the  $(v+1)^{\text{th}}$  root of the first derivative of the Bessel's function  $J_m$ :

$$J'_m(\gamma_{mv}) = 0. \quad (5.47a)$$

The first values of  $\gamma_{mv}$  for  $v = 0, 1, 2, 3$  are

$$\begin{aligned} \gamma_{0v} &= \{0.00, 3.83, 7.02, 10.17\}, \\ \gamma_{1v} &= \{1.84, 5.33, 8.54, 11.71\}, \\ \gamma_{2v} &= \{3.05, 6.71, 9.97, 13.17\}, \\ \gamma_{3v} &= \{4.20, 8.02, 11.35, 14.59\}. \end{aligned} \quad (5.47b)$$

The substitution of the approximated eigenvalues  $k_{wmv}^{(0)}$  (5.46b) into the equation of dispersion (5.14) gives the radial wavenumber component  $k_{rmv}(r)$

$$k_{rmv}^2(r) = \frac{\gamma_{mv}^2}{R^2} - \frac{m^2}{r^2}, \quad (5.48)$$



where the value for  $r = R$  leads to the estimation of the factor  $(1 - k_{0r}^2 / k_0^2)$  in the expression of  $\beta_a$  (5.44) for which the radial component  $k_{0r}$  of the real wavenumber  $k_0$  is nothing else other than the component  $k_{rmv}(R)$  of (5.48),

$$1 - \frac{k_{0r}^2}{k_0^2} = 1 - \frac{k_{rmv}^2(R)}{k_0^2} = 1 - \frac{1}{k_0^2} \left[ \frac{\gamma_{mv}^2}{R^2} - \frac{m^2}{R^2} \right] = \frac{\frac{m^2}{R^2} + k_{zmv}^2}{\frac{\gamma_{mv}^2}{R^2} + k_{zmv}^2}, \quad (5.49)$$

the factor  $(1 - k_{0r}^2 / k_0^2)$  denoting the sinus of the angle of incident of the  $(m, \nu)^{th}$  mode on the wall for a propagative mode.

5.1.4.3. *Approximated propagation constant (Neumann's boundary conditions)*

By following the approach taken in section 4.5.4 relative to the nature of propagative and evanescent modes in guides and beginning with the relation of dispersion (5.14)

$$k_{zmv}^2 = k_0^2 - k_{wmv}^2,$$

and then applying this relationship to the case where the visco-thermal wall admittance  $\beta_a$  is ignored (Neumann's condition) while considering equation (5.46b) leads to

$$k_{zmv}^2 = k_0^2 - \left( \frac{\gamma_{mv}}{R} \right)^2. \quad (5.50a)$$

The  $(m, \nu)$  modes, of which frequency  $\frac{c_0 \gamma_{mv}}{2\pi R}$  is smaller than the frequency  $\frac{c_0 k_0}{2\pi}$  of the acoustic wave generated by the source such that

$$k_0 > \gamma_{mv} / R, \quad (5.50b)$$

are propagative ( $k_{zmv}$  is real) with a phase velocity along the z-axis given by

$$c_{\varphi mv} = \frac{\omega}{k_{zmv}} = \frac{\omega}{\sqrt{k_0^2 - \frac{\gamma_{mv}^2}{R^2}}}. \quad (5.51)$$

This phase velocity tends to infinity for the modes for which eigenfrequency is equal to the frequency of the wave (cut-off frequency of the considered mode) since, in these conditions, the surfaces of equal phase are parallel to the  $\vec{Oz}$  axis. The propagation is purely radial and along the azimuth. The associated group velocity, speed of propagation of the energy, can then be written, for the  $(m, \nu)^{\text{th}}$  mode, as

$$c_{\text{gm}\nu} = \frac{1}{\partial k_{\text{zmv}} / \partial \omega} = \frac{1}{\frac{\partial}{\partial \omega} \sqrt{\frac{\omega^2}{c_0^2} - \frac{\gamma_{\text{m}\nu}^2}{R^2}}} = \frac{c_0 k_{\text{zmv}}}{k_0}. \tag{5.52}$$

This group velocity is null for a mode for which eigenfrequency is equal to the frequency of excitation (cut-off frequency of the considered mode) meaning that the energy is not convected by the considered mode.

The  $(m, \nu)$  modes, of which frequency  $\frac{c_0 \gamma_{\text{m}\nu}}{2\pi R}$  is greater than the frequency  $\frac{c_0 k_0}{2\pi}$  of the acoustic wave generated by the source such that

$$k_0 < \gamma_{\text{m}\nu} / R,$$

are evanescent ( $k_{\text{zmv}}$  is a pure imaginary). This is represented by an exponential decrease of the mode in the form  $e^{-ik_{\text{zmv}}z} = e^{-|k_{\text{zmv}}|z}$ . Consequently, these modes exist only at the immediate vicinity of the point where they are created. They do not contribute to the downstream transfer of energy in the guide.

These conclusions can be verified by calculating the energy flux at any point, a calculation that is equivalent to the one carried out in section 4.5.4.3, by replacing in equations (4.118) to (4.127) the factor

$$\begin{aligned} \int_0^{L_x} dx \cos\left(\frac{m\pi x}{L_x}\right) \cos\left(\frac{q\pi x}{L_x}\right) \int_0^{L_y} dy \cos\left(\frac{n\pi y}{L_y}\right) \cos\left(\frac{r\pi y}{L_y}\right) \\ = \frac{L_x L_y \delta_{mq} \delta_{nr}}{(2 - \delta_{m0})(2 - \delta_{n0})} \end{aligned}$$

by

$$\int_0^R r dr \int_0^{2\pi} d\varphi \begin{bmatrix} \cos \\ \sin \end{bmatrix} (m\varphi) J_m(k_{w_{mv}} r) \begin{bmatrix} \cos \\ \sin \end{bmatrix} (q\varphi) J_q(k_{w_{qp}} r) = \pi R^2 \zeta_{mn}^{(\epsilon)} \delta_{mq} \delta_{\nu p},$$

where  $\zeta_{mn}^{(\epsilon)}$  are the normalization constants.

Equation (4.124) expressing the energy flux becomes

$$\Phi_z = \frac{\pi R^2}{2\rho_0 c_0^2} \sum_{m,n=0}^{m_0,n_0} \left[ |A_{mn}|^2 c_{gmn}^{(c)} \zeta_{mn}^{(c)} + |B_{mn}|^2 c_{gmn}^{(s)} \zeta_{mn}^{(s)} \right] \quad (5.53)$$

The conclusions drawn from equation (4.124) still hold here.

Note: for a given frequency of the source and a given radius of the tube, such that all the modes with non-null indexes  $m$  and  $\nu$  are evanescent, only the  $(0,0)$ th mode is propagative. The characteristics of this mode do not depend on the variables  $(r, \varphi)$ . It is the plane mode of wavenumber  $k_{z00} = k_0$ . The tube, in low frequencies, is a system that transforms an undefined wave into a plane wave within a very short distance from where the incident wave is generated.

#### 5.1.4.4. Constant of propagation (mixed boundary condition)

In practice, the wall admittance  $\beta_a$  is never null and, consequently, the constant of propagation is neither real nor pure imaginary. For the modes that were previously identified as propagative, the constant of propagation has a non-null imaginary part that accounts for the reactive and dissipative effects of the boundary layers. The imaginary part is smaller than the real part, yet contributes and accounts for the attenuation of the modal amplitude during propagation in the tube. Similarly, the real part of the propagation constant of evanescent modes is non-null.

The propagation constant must then be written as

$$k_{z_{mv}}^2 = k_0^2 - k_{w_{mv}}^2, \quad (5.54)$$

where  $k_{w_{mv}}$  is the solution of equation (4.56a) and translates the boundary condition at  $r = R$ :

$$k_{w_{mv}} J'_m(k_{w_{mv}} R) = -ik_0 \beta_a J_m(k_{w_{mv}} R). \quad (5.55)$$

By writing that the admittance  $\beta_a$  remains small, the eigenvalues  $k_{w_{mv}}$  (solutions to equation (5.55)) remain close to the eigenvalues  $k_{w_{mv}}^{(0)} = \gamma_{mv} / R$  of equation (5.46a) that correspond to Neumann's boundary conditions. Thus, an approximated solution of equation (5.55) can be calculated by writing that

$$k_{w_{mv}} R = \gamma_{mv} + \varepsilon_{mv}, \quad (5.56)$$

where  $\varepsilon_{mv} \ll \gamma_{mv}$  for  $m$  and/or  $v \neq 0$ .

Since by definition  $J'_m(\gamma_{mv}) = 0$  and  $\gamma_{00} = 0$ , the expansion at the lowest order of equation (5.55) leads,

$$\text{-- for } m = v = 0, \text{ to } \frac{1}{R} \varepsilon_{00} J'_0(\varepsilon_{00}) = -ik_0 \beta_a J_0(\varepsilon_{00}), \quad (5.57)$$

$$\text{-- for } m \text{ and/or } v \neq 0, \text{ to } \frac{1}{R} \varepsilon_{mv} \gamma_{mv} J''_m(\gamma_{mv}) = -ik_0 \beta_a J_m(\gamma_{mv}). \quad (5.58)$$

Solving equation (5.57) is straightforward. By writing that

$$J'_0(\varepsilon_{00}) = -J_1(\varepsilon_{00}) \approx -\frac{\varepsilon_{00}}{2} \text{ and } J_0(\varepsilon_{00}) \approx 1,$$

one obtains

$$\varepsilon_{00}^2 \approx 2i R k_0 \beta_a,$$

and, according to (5.54) and to the expression of  $\beta_a$ ,

$$k_{z00}^2 \approx k_0^2 - \frac{\varepsilon_{00}^2}{R^2} = k_0^2 - i \frac{1+i}{\sqrt{2}} \frac{2}{R} k_0^{3/2} \left[ \sqrt{\ell'_v} + (\gamma-1) \sqrt{\ell_h} \right],$$

or, for a wave propagating in the positive  $z$ -direction,

$$k_{z00}^2 = k_0^2 [1 + (1-i) \eta_{00}] \quad (5.59)$$

$$\text{with } \eta_{00} = \frac{1}{\sqrt{2}} \frac{2}{R} \frac{1}{\sqrt{k_0}} \left[ \sqrt{\ell'_v} + (\gamma-1) \sqrt{\ell_h} \right].$$

This result is identical to those obtained from equations (4.94), (4.95) and subsequent equations.

The solution of equation (5.58) requires the use of the differential equation (5.15) satisfied by the Bessel's function  $J_m$ . Writing this equation for  $k_w \approx \gamma_{mv} / R$  at  $r = R$  yields

$$\frac{\gamma_{mv}^2}{R^2} J_m''(\gamma_{mv}) = -\frac{\gamma_{mv}/R}{R} J_m'(\gamma_{mv}) - \left( \frac{\gamma_{mv}^2}{R^2} - \frac{m^2}{R^2} \right) J_m(\gamma_{mv}),$$

or, since

$$\frac{J_m''(\gamma_{mv})}{J_m(\gamma_{mv})} = -(2 - m^2 / \gamma_{mv}^2). \quad (5.60)$$

The substitution of  $\varepsilon_{mv}$  from equation (5.58) into equation (5.56) gives the following eigenvalues:

$$k_{w_{mv}} = \frac{\gamma_{mv}}{R} + ik_0 \beta_a \frac{1}{\gamma_{mv}} \frac{1}{1 - m^2 / \gamma_{mv}^2}.$$

Consequently, the propagation constant is given by

$$k_{z_{mv}}^2 = k_0^2 - \frac{\gamma_{mv}^2}{R^2} - i \frac{2}{R} k_0 \beta_a \frac{1}{1 - m^2 / \gamma_{mv}^2}, \quad (5.61)$$

or:

$$k_{z_{mv}}^2 = k_0^2 - \frac{\gamma_{mv}^2}{R^2} + \frac{1-i}{\sqrt{2}} \frac{2}{R} k_0^{3/2} \left[ \left( 1 - \frac{k_r^2}{k_0^2} \right) \sqrt{\ell'_v} + (\gamma - 1) \sqrt{\ell_h} \right] \frac{1}{1 - m^2 / \gamma_{mv}^2}, \quad (5.62)$$

where the factor  $1/(1 - m^2 / \gamma_{mv}^2)$  accounts for the successive reflections of helicoidal waves (see the following section) on the walls, at each cycle, and where the imaginary part translates the attenuation of the acoustic field in the initial direction of propagation.

Note: the comment at the end of section 4.5.3.2 is valid for the modes of a cylindrical close cavity.

5.1.4.5. *Helicoidal modes in cylindrical tubes with circular sections*

The form of the solution (5.45) of the problem (5.44) can also be written as

$$p = \sum_{m,v=0}^{\infty} \left[ \alpha_{mv} e^{im\phi} + \beta_{mv} e^{-im\phi} \right] J_m(k_{wmv}r) e^{-ik_{zmv}z} e^{i\omega t}. \tag{5.63}$$

The surfaces of equal phase are given by

$$\pm m\phi - k_{zmv}z + \omega t = \text{constant}. \tag{5.64}$$

The corresponding wave propagates in the z-direction with a phase velocity (5.64)

$$c_{\phi z} = \left. \frac{\partial z}{\partial t} \right|_{\phi} = \frac{\omega}{k_{zmv}}, \tag{5.65}$$

while spinning around the axis of the tube with an angular velocity (5.64)

$$\Omega_{\phi\phi} = \left. \frac{\partial \phi}{\partial t} \right|_z = \pm \frac{\omega}{m}. \tag{5.66}$$

The  $\pm$  signs denote the two types of modes: rotational and anti-rotational (Figure 5.4).

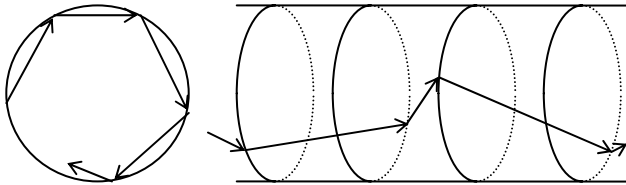
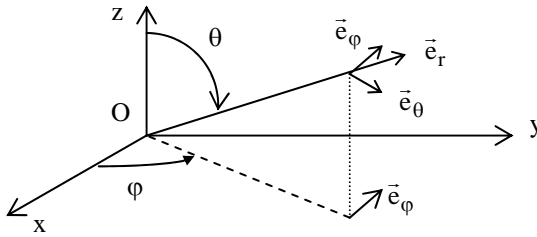

Figure 5.4. Ray tracing of a helicoidal mode

5.2. Basic solutions to the equations of linear propagation in spherical coordinates

5.2.1. *General solution of the wave equation*

The unit vectors in the spherical coordinate systems are denoted  $\vec{e}_r$ ,  $\vec{e}_\theta$  and  $\vec{e}_\phi$  (Figure 5.5).



**Figure 5.5.** Spherical coordinates system

The usual operators are then

$$d\vec{r} = dr \vec{e}_r + r d\theta \vec{e}_\theta + r \sin \theta d\varphi \vec{e}_\varphi, \tag{5.67}$$

$$\text{grad}U = \frac{\partial U}{\partial r} \vec{e}_r + \frac{1}{r} \frac{\partial U}{\partial \theta} \vec{e}_\theta + \frac{1}{r \sin \theta} \frac{\partial U}{\partial \varphi} \vec{e}_\varphi, \tag{5.68}$$

$$\text{div} \vec{A} = \frac{1}{r^2} \frac{\partial(r^2 A_r)}{\partial r} + \frac{1}{r \sin \theta} \frac{\partial(\sin \theta A_\theta)}{\partial \theta} + \frac{1}{r \sin \theta} \frac{\partial A_\varphi}{\partial \varphi}, \tag{5.69}$$

$$\begin{aligned} \text{rot} \vec{A} = & \frac{1}{r \sin \theta} \left[ \frac{\partial(\sin \theta A_\varphi)}{\partial \theta} - \frac{\partial A_\theta}{\partial \varphi} \right] \vec{e}_r \\ & + \frac{1}{r} \left[ \frac{1}{\sin \theta} \frac{\partial A_r}{\partial \varphi} - \frac{\partial(r A_\varphi)}{\partial r} \right] \vec{e}_\theta \\ & + \frac{1}{r} \left[ \frac{\partial(r A_\theta)}{\partial r} - \frac{\partial A_r}{\partial \theta} \right] \vec{e}_\varphi, \end{aligned} \tag{5.70}$$

$$\Delta U = \text{div grad}U = \frac{\partial^2 U}{\partial r^2} + \frac{2}{r} \frac{\partial U}{\partial r} + \frac{1}{r^2 \sin \theta} \frac{\partial}{\partial \theta} \left( \sin \theta \frac{\partial U}{\partial \theta} \right) + \frac{1}{r^2 \sin^2 \theta} \frac{\partial^2 U}{\partial \varphi^2}, \tag{5.71}$$

$$\Delta \vec{A} = \text{grad div} \vec{A} - \text{rot rot} \vec{A}. \tag{5.72}$$

The equation of propagation for the acoustic pressure, away from any source, becomes

$$\nabla^2 p = \left[ \frac{1}{r^2} \frac{\partial}{\partial r} \left( r^2 \frac{\partial}{\partial r} \right) + \frac{1}{r^2 \sin \theta} \frac{\partial}{\partial \theta} \left( \sin \theta \frac{\partial}{\partial \theta} \right) + \frac{1}{r^2 \sin^2 \theta} \frac{\partial^2}{\partial \varphi^2} - \frac{1}{c^2} \frac{\partial^2}{\partial t^2} \right] p = 0. \tag{5.73}$$

The solutions are functions of independent variables:

$$R(r)\Theta(\theta)\Phi(\varphi)T(t). \tag{5.74}$$

By following a similar process as in section 4.2.2 from equation (4.24) to (4.31), the substitution of equation (5.74) into (5.73) yields, consecutively

$$\begin{aligned} \frac{1}{R} \frac{d^2R}{dr^2} + \frac{2}{Rr} \frac{dR}{dr} + \frac{1}{\Theta r^2 \sin \theta} \frac{d}{d\theta} \left[ \sin \theta \frac{d\Theta}{d\theta} \right] + \frac{1}{\Phi r^2 \sin^2 \theta} \frac{d^2\Phi}{d\varphi^2} \\ = \frac{1}{Tc^2} \frac{d^2T}{dt^2} = -k^2, \end{aligned}$$

or

$$\frac{d^2T}{dt^2} + \omega^2 T = 0, \text{ where } \omega^2 = k^2 c^2 \tag{5.75}$$

and

$$\begin{aligned} -\frac{1}{\Theta \sin \theta} \frac{d}{d\theta} \left( \sin \theta \frac{d\Theta}{d\theta} \right) - \frac{1}{\Phi \sin^2 \theta} \frac{d^2\Phi}{d\varphi^2} \\ = \frac{r^2}{R^2} \frac{d^2R}{dr^2} + \frac{2r}{R} \frac{dR}{dr} + k^2 r^2 = n(n+1), \end{aligned}$$

thus

$$\left[ \frac{d^2}{dr^2} + k_r^2(r) \right] (rR) = 0, \text{ with } k_r^2(r) = k^2 - \frac{n(n+1)}{r^2}, \tag{5.76}$$

and finally

$$\frac{\sin \theta}{\Theta} \frac{d}{d\theta} \left( \sin \theta \frac{d}{d\theta} \Theta \right) + n(n+1) \sin^2 \theta = -\frac{1}{\Phi} \frac{d^2\Phi}{d\varphi^2} = m^2.$$

By denoting  $\mu = \cos \theta$ ,

$$(1-\mu^2) \frac{1}{r^2} \frac{d^2\Theta}{d\mu^2} - \frac{2\mu}{r^2} \frac{d\Theta}{d\mu} + k_\theta^2(r, \theta) \Theta = 0 \tag{5.77a}$$

$$\text{with } k_\theta^2(r, \theta) = \frac{1}{r^2} \left[ n(n+1) - \frac{m^2}{1-\mu^2} \right], \tag{5.77b}$$



and

$$\frac{1}{r^2 \sin^2 \theta} \frac{d^2 \Phi}{d\varphi^2} + k_\varphi^2(r, \theta) \Phi = 0, \quad (5.78a)$$

$$\text{with } k_\varphi^2(r, \theta) = \frac{m^2}{r^2 \sin^2 \theta}. \quad (5.78b)$$

The sum  $k_\theta^2(r, \theta) + k_\varphi^2(r, \theta) = n(n+1)/r^2$  does not depend on the coordinate  $\theta$  and its substitution into equation (5.76) leads to the following equation of dispersion:

$$k^2 = k_r^2(r) + k_\theta^2(r, \theta) + k_\varphi^2(r, \theta). \quad (5.79)$$

The general solutions to equations (5.75), (5.76), (5.77) and (5.78) are, respectively

$$T = e^{i\omega t} \quad (\text{see equation (4.26)}),$$

$$R = A_{1n} j_n(kr) + A_{2n} n_n(kr), \quad \text{or } R = B_{1n} h_n^-(kr) + B_{2n} h_n^+(kr), \quad (5.80)$$

$$\Theta = P_{nm}(\cos \theta), \quad (5.81)$$

$$\Phi = \alpha_{1m} \cos(m\varphi) + \alpha_{2m} \sin(m\varphi), \quad \text{or } \alpha_m \cos(m\varphi + \varphi_0)$$

$$\text{or } \beta_m \sin(m\varphi + \psi_0) \quad \text{or } a_{1m} e^{im\varphi} + a_{2m} e^{-im\varphi}. \quad (5.82)$$

The general solution of equation (5.73) is a linear combination (sum over all  $n$  and  $m$ ) of the solutions (5.74) that form a basis of the considered space (see Appendix to Chapter 4).

The functions  $(j_n)$  are  $n^{\text{th}}$  order spherical Bessel's functions of the first kind ( $n_n$ )  $n^{\text{th}}$  order spherical Bessel's functions of the second kind (or spherical Neumann's functions),  $(h_n^-)$  divergent  $n^{\text{th}}$  order spherical Hankel's functions and  $(h_n^+)$  convergent  $n^{\text{th}}$  order spherical Hankel's functions.

The functions  $P_{nm}(\cos \theta)$  are Legendre's functions that can be expressed using Legendre's  $n^{\text{th}}$  order polynomial functions as follows:

$$P_{nm}(\cos \theta) = \sin^m \theta \frac{d^m P_n(\cos \theta)}{d(\cos \theta)^m}, \quad n, m = 1, 2, 3, \text{etc.} \quad n > m, \quad (5.83)$$

where the Legendre's polynomial functions are given by

$$\begin{aligned}
 P_0 &= 1, \quad P_1 = \cos \theta, \\
 P_2 &= \frac{1}{2}(3 \cos^2 \theta - 1), \dots, \quad (m+1)P_{m+1} = (2m+1) \cos \theta P_m - mP_{m-1}.
 \end{aligned}
 \tag{5.84}$$

Neumann's functions are divergent at the origin, consequently they cannot appear in the solutions to a problem in a domain (D) that contains the origin.

The functions  $Y_{nm}^{(1)}$  and  $Y_{nm}^{(2)}$ , called "spherical harmonics", are respectively defined by the products  $\cos(m\varphi)P_{nm}(\cos \theta)$  and  $\sin(m\varphi)P_{nm}(\cos \theta)$ . The spherical Bessel's functions are related to their cylindrical equivalents by

$$j_n(kr) = \sqrt{\frac{\pi}{2}} \frac{J_{n+1/2}(kr)}{\sqrt{kr}}, \tag{5.85a}$$

$$n_n(kr) = \sqrt{\frac{\pi}{2}} \frac{N_{n+1/2}(kr)}{\sqrt{kr}}, \tag{5.85b}$$

where  $J_{n+1/2}(z) = (-1)^n \sqrt{\frac{\pi}{2}} z^{n+1/2} \left( \frac{1}{z} \frac{d}{dz} \right)^n \left( \frac{\sin z}{z} \right)$ ,

and  $N_{n+1/2}(z) = (-1)^n J_{-n-1/2}$ .

The function  $\sin(kr)$ , which generates all these functions, shows that these solutions are well suited to the description of stationary waves.

The spherical Hankel's functions are then defined by

$$h_n^\pm(z) = j_n(z) \pm i n_n(z) = \sqrt{\frac{\pi}{2z}} H_{n+1/2}^\pm(z), \tag{5.86}$$

where  $H_{n+1/2}^\pm(z)$  are the cylindrical Hankel's functions.

Hankel's functions can also be written in a form that reveals their suitability to the problems of wave propagation:

$$h_n^\pm(kr) = i^{n+1} \frac{e^{\pm ikr}}{kr} f_n(\mp ikr), \tag{5.87}$$

where  $f_n(z) = \sum_{s=0}^n \frac{(n+s)!}{(n-s)!s!} \left( \frac{1}{2z} \right)^s$  are the Stokes functions.

For  $kr \gg 1$  (far field),  $f_n \approx 1$  and for  $kr \ll 1$  (near field)  $f_n \approx \frac{(2n)!}{n!} \left(\frac{1}{2z}\right)^n$ .

According to equation (5.87), it appears that  $h_n^-$  represents a diverging wave while  $h_n^+$  represents a converging wave.

### 5.2.2. Progressive spherical waves

#### 5.2.2.1. Radiation from a vibrating sphere with axial symmetry

The wall of a spherical source of radius  $a$ , centered at the origin of the coordinate system, vibrates with an angular frequency  $\omega$ . Its radial velocity is given by Figure 5.6a:

$$v_a = v(\theta)e^{i\omega t}. \tag{5.88}$$

The effects due to the tangential velocity component are ignored.

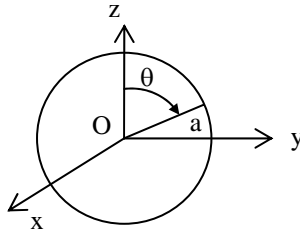

**Figure 5.6a.** Spherical source centered at the origin of the coordinate system

The pulsating sphere radiates in an infinite domain of dissipative fluid, initially at rest. Since the resulting field is independent of the variable  $\phi$  (as is the motion of the source), the problem can be written as

$$\left\{ \begin{array}{l} \left[ \frac{1}{r^2} \frac{\partial}{\partial r} \left( r^2 \frac{\partial}{\partial r} \right) + \frac{1}{r^2 \sin \theta} \frac{\partial}{\partial \theta} \left( \sin \theta \frac{\partial}{\partial \theta} \right) + k^2 \right] p = 0, \quad r > a, \\ \frac{i}{k_0 \rho_0 c_0} \frac{\partial p}{\partial r} = v(\theta), \quad r = a, \\ \text{Sommerfield's condition at infinity} \\ \text{(no back-propagating wave).} \end{array} \right. \tag{5.89}$$

Over the interval  $\theta \in [0, \pi]$ , the Legendre's function is a basis with respect to which the amplitude of the source vibration velocity  $v(\theta)$  can be expanded:

$$v(\theta) = \sum_{n=0}^{\infty} V_n P_n(\cos \theta). \tag{5.90}$$

The expansion coefficients  $V_n$  are obtained by applying the orthogonality relationship to Legendre's polynomial functions

$$\int_0^{\pi} P_m(\cos \theta) P_n(\cos \theta) \sin \theta d\theta = \left( n + \frac{1}{2} \right)^{-1} \delta_{mn}, \tag{5.91}$$

that is, by multiplying each term of equation (5.90) by  $P_m(\cos \theta)$  and integrating over the interval  $[0, \pi]$ ,

$$V_n = \left( n + \frac{1}{2} \right) \int_0^{\pi} v(\theta) P_n(\cos \theta) \sin \theta d\theta. \tag{5.92}$$

The pressure field is independent of  $\phi$  and propagates to infinity. It can then be written as

$$p = \sum_{n=0}^{\infty} A_n P_n(\cos \theta) h_n^-(kr) e^{i\omega t}, \tag{5.93}$$

the associated radial velocity being

$$v_r = \frac{i}{k_0 \rho_0 c_0} \frac{\partial p}{\partial r} = \frac{i}{k_0 \rho_0 c_0} \sum_{n=0}^{\infty} A_n P_n(\cos \theta) k h_n^{-'}(kr) e^{i\omega t}, \tag{5.94}$$

where  $h_n^{-'}$  denotes the derivative of  $h_n^-$  with respect to  $kr$ .

The boundary condition at  $r = a$  (5.89) leads, identifying term-by-term (same method as used to obtain equation 5.92), to the expansion coefficients of equation (5.93)

$$A_n = -i \rho_0 c_0 V_n / h_n^{-'}(ka), \tag{5.95}$$

where the approximation  $k/k_0 \approx 1$  is assumed.

Various vibro-acoustic indicators of interest are now expressed using the dimensionless notation

$$\psi(\theta) = \frac{1}{k_0 a} \sum_{n=0}^{\infty} \frac{V_n}{V_0} \frac{P_n(\cos \theta)}{B_n(ka)} e^{i[(n+1)\pi/2 + \phi_n(ka)]}, \quad (5.96)$$

$$\text{with } B_n(kr) e^{-i\phi_n(kr)} = i h_n^-(kr).$$

The components of the particle velocity in the far field are

$$v_{r_\infty} = a V_0 \psi(\theta) \frac{1}{r} \left( 1 + \frac{1}{ikr} \right) e^{-ikr} e^{i\omega t}, \quad (5.97)$$

$$v_{\theta_\infty} = \frac{i}{k_0 \rho_0 c_0} \frac{1}{r} \frac{\partial p_\infty}{\partial \theta} = i \frac{a V_0}{k_0} \psi(\theta) \frac{e^{-ikr}}{r^2} e^{i\omega t}. \quad (5.98)$$

The component  $v_{\theta_\infty}$  decreases rapidly for  $r \rightarrow \infty$ .

The components of the acoustic intensity in the far field are

$$I_{r_\infty} = \frac{\rho_0 c_0}{2} \left( \frac{a V_0}{r} \right)^2 |\psi|^2, \quad (5.99)$$

$$I_{\theta_\infty} = 0. \quad (5.100)$$

The total radiated power is obtained by integrating  $I_{r_\infty}$  over a sphere the diameter of which tends to infinity:

$$\mathcal{P} = \iint I_{r_\infty} r^2 \sin \theta d\theta d\phi, \quad (5.101)$$

or, by substituting (5.99) and considering the orthogonality relation (5.91),

$$\mathcal{P} = \frac{2\pi \rho_0 c_0}{k_0^2} \sum_{n=0}^{\infty} \frac{V_n^2}{(2n+1) B_n^2(ka)}. \quad (5.102)$$

### 5.2.2.2. Radiation from a vibrating section of sphere

This problem (Figure 5.6b) is a particular case of the problem (5.89), where the function  $v(\theta)$  (equation (5.88)) is

$$\begin{cases} v(\theta) = v_0, & 0 \leq \theta \leq \theta_0, \\ v(\theta) = 0, & \theta_0 \leq \theta \leq \pi. \end{cases} \quad (5.103)$$

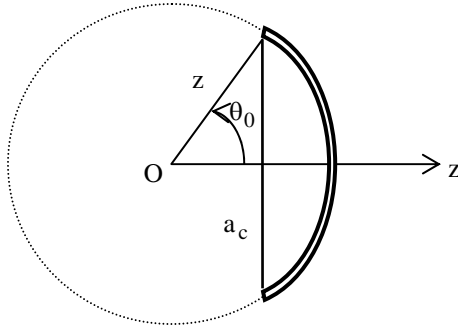

**Figure 5.6b.** Pulsating section of sphere (on a spherical baffle)

Consequently, the expansion coefficients are

$$V_n = \left( n + \frac{1}{2} \right) v_0 \int_{\cos \theta_0}^1 P_n(\mu) d\mu = \frac{v_0}{2} [P_{n-1}(\cos \theta_0) - P_{n+1}(\cos \theta_0)] \quad (5.104)$$

where  $P_{-1} = P_0 = 1$ .

The calculation and interpretation of the various indicators (particle velocity, acoustic intensity) tends to verify that the total radiated power, and consequently the real part of the radiation impedance  $\text{Re}(Z) = \mathcal{P} / (v_0^2 / 2)$ , tend to zero when the radius  $a_c$  does so. The radiated energy reaches a maximum when the product  $ka_c$  is greater than a few units and, correlatively, the directivity pattern (magnitude of the acoustic pressure as a function of the angle  $\theta$ ) becomes more complex as the products  $ka_c$  and  $ka$  increase, similarly as the frequency increases.

Note: the radiation impedance of the radiating surface  $S_c = \pi a_c^2$ ,

$$Z = \mathcal{P} / (v_0^2 / 2) = \frac{1}{v_0} \iint_{S_c} p(r = a) dS_c, \quad (5.105)$$

tends to the product of the radiating surface  $S_c$  by the characteristic impedance of the medium of propagation when the dimensions of the surface  $S_c$  become much greater than the considered wavelength, thus

$$\lim_{ka_c \rightarrow \infty} Z = \pi a_c^2 \rho_0 c_0. \quad (5.106)$$

The latter result is very general by nature.

5.2.2.3. Radiation from an oscillating sphere and acoustic field from a dipole

5.2.2.3.1. The oscillating sphere

Once again, this problem is a particular case of the problem (5.89), where the function  $v(\theta)$  (equation (5.88)) is

$$v(\theta) = V_1 \cos \theta. \tag{5.107}$$

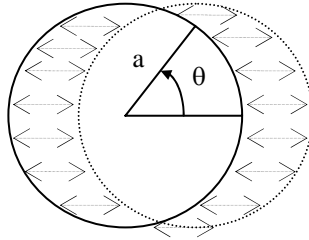

Figure 5.7. Oscillating sphere

Consequently, the expansions coefficients are

$$V_n = V_1 \delta_{n1}, \tag{5.108}$$

and the pressure field is

$$p = \frac{-i\rho_0 c_0 V_1}{h_1^-(ka)} h_1^-(kr) \cos \theta e^{i\omega t}. \tag{5.109}$$

The substitution of the expression (5.87) of  $h_1^-(kr)$  leads to the expression of the acoustic pressure

$$p = \frac{i\rho_0 c_0 V_1}{h_1^-(ka)} \frac{e^{-ikr}}{kr} \left( 1 + \frac{1}{ikr} \right) \cos \theta e^{i\omega t}. \tag{5.110}$$

The interpretation of this result requires the calculation of the acoustic field of a dipole.

5.2.2.3.2. The acoustic field from a dipole

The acoustic field created at a point  $\vec{r}_p$  by a harmonic monopole source located at  $\vec{r}_0$  is written (section 3.3.1, section 3.3.2, and equation (3.44)) as

$$\frac{e^{-ik|\vec{r}_p - \vec{r}_0|}}{4\pi|\vec{r}_p - \vec{r}_0|}.$$

The object of this paragraph is to show that the acoustic field generated by a dipole, two neighboring monopoles out of phase (Figure 5.8), can be expressed by using the vectorial function

$$\text{grad}_{\vec{r}_0} \frac{e^{-ik|\vec{r}_p - \vec{r}_0|}}{4\pi|\vec{r}_p - \vec{r}_0|} = \text{grad}_{\vec{r}_0} \frac{e^{-ikr}}{4\pi r}, \text{ with } \vec{r} = \vec{r}_p - \vec{r}_0.$$

The first component of this function,

$$\frac{\partial}{\partial x_0} \left[ \frac{e^{-ik\sqrt{(x_p - x_0)^2 + (y_p - y_0)^2 + (z_p - z_0)^2}}}{4\pi\sqrt{(x_p - x_0)^2 + (y_p - y_0)^2 + (z_p - z_0)^2}} \right],$$

can be written as

$$\frac{\partial(x_p - x_0)^2}{\partial x_0} \frac{\partial r}{\partial(x_p - x_0)^2} \frac{\partial}{\partial r} \left( \frac{e^{-ikr}}{4\pi r} \right) = \frac{1}{4\pi} \frac{x_p - x_0}{r} ik \left( 1 + \frac{1}{ikr} \right) \frac{e^{-ikr}}{r},$$

while similar expressions can be found for the two other components. Finally,

$$\text{grad}_{\vec{r}_0} \left( \frac{e^{-ik|\vec{r}_p - \vec{r}_0|}}{4\pi|\vec{r}_p - \vec{r}_0|} \right) = \frac{ik}{4\pi} \left( 1 + \frac{1}{ikr} \right) \frac{e^{-ikr}}{r} \frac{\vec{r}}{r}. \tag{5.111}$$

Equation (5.111) is nothing other than the gradient of the vectorial variable  $\vec{r}_0$  of the Green's function  $G(\vec{r}_p, \vec{r}_0)$  (equation (3.43)) that represents the velocity potential  $\Phi(\vec{r}_p)$  ( $G = -\Phi$ ) generated at  $\vec{r}_p$  in the infinite domain by a monopole located at  $\vec{r}_0$  for a punctual source of unit volume velocity. The pressure field is  $p = i\omega\rho_0 G$ . The scalar product  $\text{grad}_{\vec{r}_0} G(\vec{r}_p, \vec{r}_0) d\vec{r}_0$  is equal to the difference  $G(\vec{r}_p, \vec{r}_0 + d\vec{r}_0) - G(\vec{r}_p, \vec{r}_0)$  that represents the acoustic field generated by two close monopoles, one at  $(\vec{r}_0)$  and the other at  $(\vec{r}_0 + d\vec{r}_0)$  radiating out of phase. This particular system is called a dipole, the associated field being called a dipolar field, and the equation of propagation satisfied by the dipolar field introduces the operator  $\text{grad}_{\vec{r}_0} \delta(\vec{r} - \vec{r}_0)$  in its right-hand side term.



The general expression of the acoustic dipolar field is therefore given by ( $k \sim k_0$ )

$$p = -k_0^2 \rho_0 c_0 \left( 1 + \frac{1}{ik_0 r} \right) \frac{e^{-ikr}}{4\pi r} Q_0 d\vec{r}_0 \cdot \frac{\vec{r}}{r}, \tag{5.112}$$

where  $Q_0$  denotes the volume velocity of each monopole (volume of fluid introduced in the medium per unit of time),  $d\vec{r}_0$  denotes the orientation of the dipole (Figure 5.8),  $\vec{r}$  denotes the vector locating the receiving point  $\vec{r}_p$  from the dipole location ( $\vec{r} = \vec{r}_p - \vec{r}_0$ ),  $(d\vec{r}_0 / |d\vec{r}_0|)(\vec{r}/r) = \cos \theta$  ( $\theta$  being the angle of the direction  $\vec{r}_p - \vec{r}_0$  with the axis of the dipole), and finally where  $Q_0 d\vec{r}_0$  represents the dipolar moment.

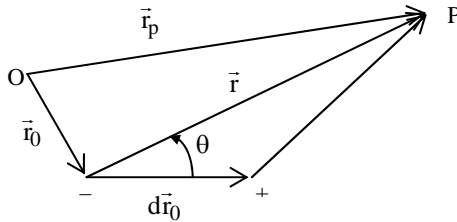

Figure 5.8. Acoustic dipole

5.2.2.3.3. The dipolar field from an oscillating sphere

Comparing the acoustic field of the oscillating sphere (equation 5.110) with the dipolar field (equation (5.112)) shows that the pressure fields depend similarly on  $r$  and  $\theta$ . These two fields present, therefore, the same characteristics. This dipolar characteristic constitutes the “exclusive” characteristics of oscillating spheres and, more generally, of any oscillating finite source. Precisely, by writing in equation (5.112) that

$$d\vec{r}_0 \cdot \frac{\vec{r}}{r} = \cos \theta |d\vec{r}_0|,$$

and in equation (5.110) (considering the expression (5.87) of the Hankel’s function  $h_n^-$ ) that

$$\lim_{a \rightarrow 0} h_1^-(ka) = \frac{2}{ik_0^3 a^3}.$$

It is straightforward to verify that equations (5.110) and (5.112) are rigorously equal if

$$Q_0 dr_0 = 2\pi V_1 a^3. \tag{5.113}$$

Consequently, an oscillating sphere of radius  $a$  significantly smaller than the wavelength, of normal vibration velocity  $V_1 \cos \theta$  (where  $V_1$  is a constant) generates a dipolar field. The equivalent dipolar moment is given by equation (5.113).

5.2.2.4. *Radiation from a pulsating sphere: the monopolar field*

Again, this problem is a particular example of the problem (5.89), where the function  $v(\theta)$  (equation (5.88)) is constant:

$$v(\theta) = Q_0 / (4\pi a^2), \tag{5.114}$$

where  $Q_0$  denotes the total volume velocity of the source and its radius.

Consequently, equations (5.90), (5.93) and (5.95) lead to

$$v_0 = Q_0 / (4\pi a^2), \tag{5.115}$$

and

$$p = -i\rho_0 c_0 \frac{Q_0}{4\pi a^2} \frac{h_0^-(kr)}{h_0^-(ka)} e^{i\omega t}, \tag{5.116}$$

where  $\bar{r}$  denotes the location of the point where the pressure field is expressed, the origin being taken at the centre of the pulsating sphere.

The monopolar field is the limit, when  $a \rightarrow 0$ , of the field generated by a pulsating sphere. When considering the expression (5.87) of  $h_0^-$ , one immediately obtains

$$p_1 = i\omega\rho_0 Q_0 \frac{e^{-ikr}}{4\pi r}. \tag{5.117}$$

Since  $p = i\omega\rho_0 G$ , equation (5.117) result is in accordance with expression (4.54) of the Green's function.

**5.2.3. Diffraction of a plane wave by a rigid sphere**

A plane wave propagating in a dissipative fluid initially at rest, in the increasing  $z$ -directions, is incident on a rigid sphere centered at the origin of the coordinate system (Figure 5.9). Since the symmetry of the problem is axial, the solution is independent of the variable  $\phi$ .

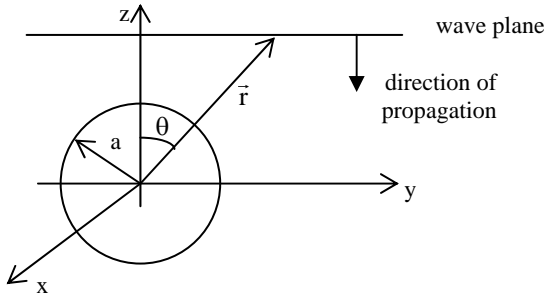

**Figure 5.9.** Diffraction of a plane wave by a rigid sphere

The amplitude of the acoustic pressure is solution to the following problem:

$$\left\{ \begin{array}{l} \left[ \frac{1}{r^2} \frac{\partial}{\partial r} \left( r^2 \frac{\partial}{\partial r} \right) + \frac{1}{r^2 \sin \theta} \frac{\partial}{\partial \theta} \left( \sin \theta \frac{\partial}{\partial \theta} \right) + k^2 \right] p = 0, \quad r > a, \\ \frac{i}{k_0 \rho_0 c_0} \frac{\partial p}{\partial r} = \frac{-1}{Z_a} p, \quad r = a, \\ \text{harmonic incident wave } p_i = P_0 e^{ikz} = P_0 e^{ikr \cos \theta}, \\ \text{Sommerfeld's condition at infinity,} \end{array} \right. \quad (5.118)$$

where the impedance  $Z_a$  introduces the reaction and dissipation in the boundary layers.

The function  $p_i$  can be expressed in the basis of admissible functions associated with the Helmholtz operator:

$$p_i = P_0 \sum_{n=0}^{\infty} (i)^n (2n+1) j_n(kr) P_n(\cos \theta). \quad (5.119)$$

The expression of the diffracted wave can also be expanded on the basis of Legendre's functions as a divergent wave of axial symmetry:

$$p_r = \sum_{n=0}^{\infty} a_n h_n^-(kr) P_n(\cos \theta). \quad (5.120)$$

The expansion coefficients  $a_n$  are obtained by writing the boundary conditions at  $r = a$  (equation (5.118)). By using the following notations:

$$\frac{\partial}{\partial r} j_n(kr) = k \frac{\partial}{\partial(kr)} \operatorname{Re} [h_n^\pm(kr)] = k \operatorname{Re} [-i B_n e^{-i\varphi_n}] = -k B_n \sin \varphi_n,$$

substituting the expressions of the particle velocity

$$v_i)_{r=a} = \frac{-P_0}{\rho_0 c_0} \sum_{n=0}^{\infty} i^{n+1} (2n+1) P_n(\cos \theta) B_n(ka) \sin[\varphi_n(ka)] \quad (5.121)$$

and

$$\begin{aligned} v_r)_{r=a} &= \frac{1}{\rho_0 c_0} \sum_n a_n P_n(\cos \theta) i \left[ \frac{\partial}{\partial(kr)} h_n^-(kr) \right]_{r=a} \\ &= \frac{1}{\rho_0 c_0} \sum_n a_n P_n(\cos \theta) B_n(ka) e^{-i\varphi_n(ka)}, \end{aligned} \quad (5.122)$$

and substituting equations (5.119) and (5.120) into the boundary conditions at  $r = a$ , one immediately obtains the coefficients  $a_n$  by identifying the results term-by-term. In the particular case where the dissipation due to the boundary layers is ignored ( $Z_a \rightarrow \infty$ ), these coefficients can be written as

$$a_n = P_0 i^{n+1} (2n+1) \sin[\varphi_n(ka)] e^{i\varphi_n(ka)}, \quad (5.123)$$

and the resulting expression of the pressure magnitude is

$$p_r = P_0 \sum_{n=0}^{\infty} i^{n+1} (2n+1) \sin[\varphi_n(ka)] e^{i\varphi_n(ka)} h_n^-(kr) P_n(\cos \theta). \quad (5.124)$$

The corresponding acoustic intensity, in the radial direction  $\bar{r}$ , can be approximately expressed as

$$\begin{aligned} I_r &= \frac{a^2}{r^2} \frac{I}{k_0^2 a^2} \sum_{m,n=0}^{\infty} (2m+1)(2n+1) \sin \varphi_m \sin \varphi_n \\ &\quad \times \cos(\varphi_m - \varphi_n) P_m(\cos \theta) P_n(\cos \theta), \end{aligned} \quad (5.125)$$

where  $I$  denotes the intensity of the incident wave  $I = P_0^2 / (2\rho_0 c_0)$  and where  $\varphi_m = \varphi_m(ka)$  and  $\varphi_n = \varphi_n(ka)$ . Consequently,

$$I_r = \frac{k^4 a^6 I}{9r^2} (1 - 3\cos\theta)^2, \quad \text{if } ka \ll 1, \tag{5.126}$$

$$I_r = I \left[ \frac{a^2}{4r^2} + \frac{a^2}{4r^2} \cot^2\left(\frac{\theta}{2}\right) J_1^2(ka \sin\theta) \right], \quad \text{if } ka \gg 1. \tag{5.127}$$

The total diffracted power can then be written as

$$\mathcal{P}_r = 2\pi a^2 I \frac{2}{k^2 a^2} \sum_{m=0}^{\infty} (2m+1) \sin^2 \varphi_m,$$

that is

$$\mathcal{P}_r \approx \frac{16\pi}{9} k^4 a^6 I, \quad ka \ll 1, \tag{5.128}$$

$$\mathcal{P}_r \approx 2\pi a^2 I, \quad ka \gg 1. \tag{5.129}$$

Whatever expression is used for the acoustic intensity, the first term corresponds to a diffraction of spherical symmetry, whereas the other  $\theta$ -dependent terms account for the angular phenomena related to the diffraction. The greater the orders  $n$  and  $m$ , the more rapid the variations of the diffraction pattern with respect to variations of  $\theta$ . In practice, since sensors are of finite size, they only provide the mean value of the field within a region of space. It is therefore not necessary to conserve high orders in the expression of the diffracted pressure field.

Figure 5.10 illustrates the directivity curve of the diffracted intensity and Figure 5.11 gives the profile of the diffracted total power with respect to  $(ka)$ , normalized as follows:

$$\mathcal{P}_N = \mathcal{P}_r \frac{\rho_0 c_0}{\pi a^2 P_0^2}.$$

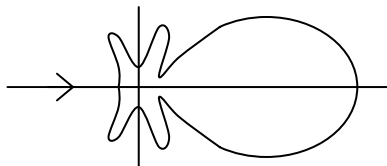

**Figure 5.10.** Example of acoustic intensity directivity pattern

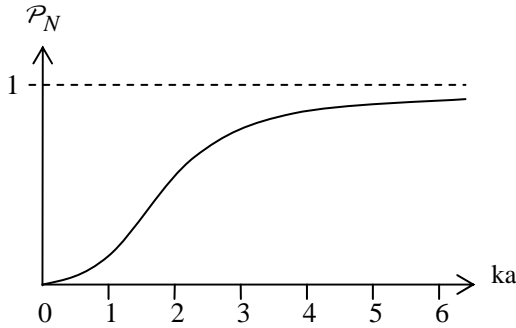

**Figure 5.11.** Profile of the total diffracted power

To quantify the error in measurement due to the presence of a spherical microphone in an acoustic field (plane wave), one can calculate the ratio  $D$  of the acoustic pressure  $p_t$  when the sphere is present over the acoustics pressure  $p_i$  when the sphere is not

$$D = p_t / p_i \tag{5.130}$$

Figure 5.12 gives the magnitude of this ratio with respect to  $(ka)$  at the point  $\theta = 0$  (facing the incident wave).

This result shows that a spherical microphone (for example) gives the correct acoustic pressure at the condition where its dimensions are inferior to the wavelength  $\lambda$  ( $ka = 2\pi a / \lambda$ ). This result holds for any other type of microphone. For short wavelengths ( $ka > 4$ ), the error can be as high as a factor of 2 (6 dB!), but is actually compensated for in practice.

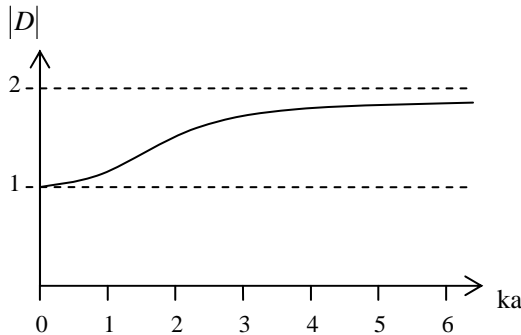

**Figure 5.12.** Module of the error (equation (5.130))

**5.2.4. The spherical cavity**

The objective of this paragraph is to find the eigenfunctions and associated eigenvalues of a spherical cavity with perfectly rigid walls, in other words, to find the solutions to the following problem:

$$\left\{ \begin{aligned} & \left[ \frac{1}{r^2} \frac{\partial}{\partial r} \left( r^2 \frac{\partial}{\partial r} \right) + \frac{1}{r^2 \sin \theta} \frac{\partial}{\partial \theta} \left( \sin \theta \frac{\partial}{\partial \theta} \right) + k_{nv}^2 \right] \psi_{mnv}(r, \theta, \varphi) = 0, \quad r < a, \\ & \frac{\partial \psi_{mnv}}{\partial r} + \frac{ik_{nv} \rho_0 c_0}{Z_a} \psi_{mnv} = 0, \quad r = a, \\ & \psi_{mnv}(r, \theta, \varphi) \text{ is finite at } r = 0, \end{aligned} \right. \quad (5.131)$$

where  $\rho_0 c_0 / Z_a$  denotes the equivalent specific admittance due to visco-thermal effects at the boundaries.

The problem is first solved in the particular case where  $\rho_0 c_0 / Z_a = 0$ . The eigenfunctions  $\psi_{mnv}^{(s,c)}$  are

$$\psi_{mnv}^{(s,c)} = N_{mnv} j_n(k_{nv} r) P_{nm}(\cos \theta) \begin{bmatrix} \sin \\ \cos \end{bmatrix} (m\varphi), \quad (5.132)$$

where  $N_{mn}$  is a constant arbitrarily chosen so that the eigenfunctions are normalized to the unit:

$$\int_0^a r^2 dr \int_0^\pi \sin \theta d\theta \int_0^{2\pi} d\varphi \left[ \psi_{mnv}^{(s,c)} \right]^2 = 1 \quad (5.133)$$

and the associated eigenvalues  $k_{nv}^{(0)}$  are given by

$$k_{nv}^{(0)} = \gamma_{nv} / a, \quad (5.134)$$

where the  $\gamma_{nv}$  factors represent the roots of the first derivative of the spherical Bessel's functions (conforming to the boundary conditions at  $r = a$ ), i.e.

$$j'_n(\gamma_{nv}) = 0. \quad (5.135)$$

Considering equations (5.76) to (5.79), according to which

$$k^2 - k_r^2(r) = k_\theta^2(r, \theta) + k_\varphi^2(r, \theta) = \frac{n(n+1)}{r^2}, \quad (5.136)$$

$$\text{with } k_{\varphi}^2(r, \theta) = \frac{m^2}{r^2 \sin^2 \theta},$$

and where the wavenumber  $k$  in the function  $j_n(kr)$  takes here the eigenvalue associated to the considered eigenfunctions, leads to

$$k_r^2(a) = \frac{\gamma_{nv}^2}{a^2} - \frac{n(n+1)}{a^2}. \tag{5.137}$$

Consequently, the factor  $(1 - k_r^2/k^2)$  in the expression of the wall admittance (equation (3.10))

$$\frac{\rho_0 c_0}{Z_a} = \frac{1+i}{\sqrt{2}} \sqrt{k} \left[ (1 - k_r^2/k^2) \sqrt{\ell'_v} + (\gamma - 1) \sqrt{\ell'_h} \right],$$

becomes

$$(1 - k_r^2/k^2) = \frac{n(n+1)}{\gamma_{nv}^2}. \tag{5.138}$$

Therefore,

$$\frac{\rho_0 c_0}{Z_a} = \frac{1+i}{\sqrt{2}} \sqrt{k_{nv}} \left[ \frac{n(n+1)}{a^2 k_{nv}^2} \sqrt{\ell'_v} + (\gamma - 1) \sqrt{\ell'_h} \right], \tag{5.139}$$

with  $k_{nv} \approx k_{nv}^0 = \gamma_{nv}/a$ .

By considering that the boundary condition at  $r=a$  of problem (5.131) is completely defined by the substitution of equation (5.139), one directly obtains the solution. The expressions of the eigenfunctions are still as in equation (5.132), but the eigenvalues are solutions to

$$k_{nv} j'_n(k_{nv} a) \approx -i k_{nv}^{(0)} \frac{\rho_0 c_0}{Z_a} j_n(k_{nv} a). \tag{5.140}$$

By solving the above equation for  $n = v = 0$  must be done separately from the other cases since  $\gamma_{00} = 0$  :

$$j_0[k_{0v}^{(0)} r] = N_{00v} \frac{\sin k_{0v}^{(0)} r}{r} \tag{5.141}$$



and

$$\frac{\partial}{\partial r} j_0[k_{0v}^{(0)}r] = N_{00v} \left[ \frac{k_{0v}^{(0)} \cos k_{0v}^{(0)}r}{r} - \frac{\sin k_{0v}^{(0)}r}{r^2} \right].$$

The equation immediately above must be null for  $r = a$ , thus

$$\operatorname{tg} k_{0v}^{(0)}r = k_{0v}^{(0)}r \tag{5.142}$$

the first solution of which is  $k_{00}^{(0)} = 0$ .

For  $n = v = 0$ , equation (5.140) becomes

$$\begin{aligned} \frac{\partial}{\partial a} j_0(k_{00}a) &= -i \frac{\rho_0 c_0}{Z_a} k_{00} j_0(k_{00}a), \\ \text{with } j_0(k_{00}a) &= N_{000} \frac{\sin(k_{00}a)}{a}. \end{aligned}$$

An approximated form of equation (5.140) is

$$k_{00} = i \frac{3}{a} \frac{\rho_0 c_0}{Z_a} = i \frac{1+i}{\sqrt{2}} \frac{3}{a} \sqrt{k_{00}} (\gamma-1) \sqrt{\ell_h}, \tag{5.143}$$

leading to

$$\sqrt{k_{00}} = \frac{i-1}{\sqrt{2}} \frac{3}{a} (\gamma-1) \sqrt{\ell_h}, \quad k_{00} = -i\sqrt{2} \frac{3}{a} (\gamma-1) \sqrt{\ell_h},$$

indicating that the modal dissipation at the wall occurs only in the thermal boundary layers and is proportional to the factor  $(3/a)$  that represents the ratio of the surface of the sphere to its volume.

For  $n$  and/or  $v \neq 0$ , the expansion of equation (5.140) at the lowest approximating order of the correction term  $\varepsilon_{nv}$  added to  $\gamma_{nv}$  to find the new eigenvalues is

$$\frac{\varepsilon_{nv}}{a} \gamma_{nv} j_n''(\gamma_{nv}) \approx -i \frac{\gamma_{nv}}{a} \frac{\rho_0 c_0}{Z_a} j_n(\gamma_{nv}), \tag{5.144}$$

with  $k_{nv}a = \gamma_{nv} + \varepsilon_{nv}$ ,

thus

$$\frac{\varepsilon_{nv}}{a} \approx -\frac{i \rho_0 c_0}{a} \frac{j_n(\gamma_{nv})}{Z_a j_n''(\gamma_{nv})}. \tag{5.145}$$

The ratio  $j_n(\gamma_{nv})/j_n''(\gamma_{nv})$  is obtained by writing equation (5.76) satisfied by the Bessel's function  $j_n$  for  $r = a$  and  $k = \gamma_{nv} / a$ . Since  $\gamma_{nv}$  is defined by  $j'(\gamma_{nv}) = 0$ , one obtains

$$\frac{\gamma_{nv}^2}{a^2} j_n''(\gamma_{nv}) + \left[ \frac{\gamma_{nv}^2}{a^2} - \frac{n(n+1)}{a^2} \right] j_n(\gamma_{nv}) = 0. \tag{5.146}$$

Consequently, equation (5.145) becomes

$$\frac{\varepsilon_{nv}}{a} \approx \frac{i \rho_0 c_0}{a} \frac{1}{Z_a [1 - n(n+1)/\gamma_{nv}^2]}, \tag{5.147}$$

leading to

$$k_{nv} \approx \frac{\gamma_{nv}}{a} + \frac{i \rho_0 c_0}{a} \frac{1}{Z_a [1 - n(n+1)/\gamma_{nv}^2]},$$

or

$$k_{nv} \approx \frac{\gamma_{nv}}{a} + \frac{i}{a} \frac{1+i}{\sqrt{2}} \sqrt{\frac{\gamma_{nv}}{a}} \left[ \frac{n(n+1)}{\gamma_{nv}^2} \sqrt{\ell_v} + (\gamma-1) \sqrt{\ell_h} \right] \frac{1}{1 - n(n+1)/\gamma_{nv}^2}. \tag{5.148}$$

Note: the field defined by equation (5.141),  $j_0[k_{0v}^{(0)}r] = N_{00v} \frac{\sin k_{0v}^{(0)}r}{r}$ , represents the spherically symmetric pressure field (independent of  $\theta$  and  $\varphi$ ) in a spherical cavity with perfectly reflecting walls. This pressure field is the sum of a divergent and a convergent spherical wave. It can be written in the form

$$\frac{e^{ik_{0v}^{(0)}r}}{r} + R_0 \frac{e^{-ik_{0v}^{(0)}r}}{r}. \tag{5.149}$$

The radial particle velocity associated to this field is

$$-\frac{ik_{0v}^{(0)}}{r} \left[ \left( -1 + \frac{1}{ik_{0v}^{(0)}r} \right) e^{ikr} + R_0 \left( 1 + \frac{1}{ik_{0v}^{(0)}r} \right) e^{-ikr} \right]$$

and must be null at  $r = 0$ , thus  $R_0 = -1$ .

Consequently, the results confirm that the pressure  $p$  is in the form  $\frac{\sin k_{0v}^{(0)}r}{r}$ .

### 5.2.5. Digression on monopolar, dipolar and 2n-polar acoustic fields

The main objective of this section is to complete the previous descriptions of monopolar and dipolar fields (the importance of which is revealed in Chapter 6) and to complete the interpretation of the solutions (5.93) expanded on the basis of the considered space.

#### 5.2.5.1. The monopolar field

According to sections 3.3.1 and 3.3.2, the monopolar acoustic field, presenting spherical surfaces of constant phase, is the solution to the problem (3.26) for a distance between the receiving point ( $\vec{r}$ ) and the center of the source ( $\vec{r}_0$ ) greater than the radius  $a$  of the source ( $R = |\vec{r} - \vec{r}_0| > a$ ) or of the problem (3.27) in the case where the spherical source is punctual (for  $R > 0$ ). It is appropriate, however, to stress the fact that the variable  $\vec{r}$  is not the same as in section 5.2.2.4 and can only be taken as such if the center of the source is at the origin of the coordinate system. Moreover, the variable  $R$  used herein cannot be equated to the function  $R$  introduced in equation (5.74).

The problem (3.27), satisfied by the monopolar acoustic field, can be written using the velocity potential  $\Phi$  as follows:

$$\left\{ \begin{array}{l} \frac{\partial^2}{\partial R^2} - \left( 1 - \ell_{vh} \frac{1}{c_0} \frac{\partial}{\partial t} \right) \frac{1}{c_0^2} \frac{\partial^2}{\partial t^2} [R \Phi(R, t)] = 0, \quad R > 0, \\ \frac{\partial \Phi(R, t)}{\partial R} = \lim_{a \rightarrow 0} \frac{Q_0(t)}{4\pi a^2}, \quad R = a \rightarrow 0, \\ \text{Sommerfeld condition at infinity,} \\ \text{(no back-propagating wave),} \end{array} \right. \quad (5.150)$$

where  $Q_0(t)$  denotes the volume of fluid introduced in the medium per unit of time by the spherical source which radius  $a$  tends to zero.

Ignoring in a first approximation the dissipation factor ( $\ell_{vh} \sim 0$ ), the general solution to the equation of propagation is a function  $R\Phi = f$  of the variable  $[\omega(t \pm R/c_0)]$  where the parameter  $\omega$ , of dimension  $s^{-1}$ , is introduced to ensure that the argument is dimensionless. Sommerfeld's condition at infinity imposes the absence of a back-propagating wave, therefore only the argument  $[\omega(t - R/c_0)]$  is considered. The condition at the origin ( $R \rightarrow 0$ ) imposes the function  $R\Phi$

$$\frac{\partial \Phi(R, t)}{\partial R} = \frac{\partial}{\partial R} \left[ \frac{f[\omega(t - R/c_0)]}{R} \right] = \lim_{R \rightarrow 0} \frac{Q_0(t)}{4\pi R^2},$$

thus

$$\lim_{R \rightarrow 0} \left[ \frac{\omega}{c_0} \frac{f'}{R} + \frac{f}{R^2} + \frac{Q_0}{4\pi R^2} \right] = 0, \tag{5.151}$$

where  $f'$  is the first derivative of the function  $f$  with respect to its argument.

By making the hypothesis that

$$\lim_{R \rightarrow 0} \left( \frac{\omega}{c} \frac{f'}{R} \right) \ll \lim_{R \rightarrow 0} \left( \frac{f}{R^2} \right), \tag{5.152}$$

leads to

$$\lim_{R \rightarrow 0} f[\omega(t - R/c_0)] = \frac{-Q_0(t)}{4\pi},$$

and subsequently to  $f \equiv \frac{-1}{4\pi} Q_0$ .

Finally, the solution to the problem (5.150) is written, ignoring dissipation and if the validity of the condition (5.152) is established, as

$$\Phi(R, t) = \frac{-1}{4\pi R} Q_0[\omega(t - R/c_0)] \tag{5.153}$$

This solution is described as “delayed potential”. For example, with an impulse source  $Q_0(t) = \omega \delta[\omega(t - t_0)] = \delta(t - t_0)$ , the solution can be written, denoting  $(t - t_0) = \tau$ , as

$$\Phi(R, t) = \frac{-\omega}{4\pi R} \delta[\omega(\tau - R/c_0)] = \frac{-\delta(\tau - R/c_0)}{4\pi R}, \tag{5.154}$$

that is identical to the solution found in section 3.3.2 (equation (3.40)).

In the case of a harmonic source  $Q_0(t) = Q_0 e^{i\omega(t-t_0)}$ , the problem (5.150) can be solved by considering the dissipation. In other words, by writing that the general solution is a function of the variable  $\omega(t \pm R/c)$  with  $c = c_0 \sqrt{1 - i\omega \ell_{vh}}$ . Thus, using the relation (5.153), the solution is immediately given by

$$\Phi(R, t) = -Q_0 \frac{e^{-ikR}}{4\pi R} e^{i\omega\tau}, \tag{5.155}$$

with  $k = \omega/c$  and  $\tau = t - t_0$ . This is the same solution as the one found in section 3.3.2 (equations (3.43) and (3.44)).

The associated acoustic pressure is

$$p = ik_0 \rho_0 c_0 Q_0 \frac{e^{-ikR}}{4\pi R} e^{i\omega\tau}. \tag{5.156}$$

By considering equations (3.29) and (3.30), expression (5.155) of  $\Phi$  is a solution to the following problem:

$$\left\{ \begin{aligned} \frac{1}{R} \left( \frac{\partial^2}{\partial R^2} + k^2 \right) (R\Phi) &= Q_0 \delta(\bar{R}) e^{i\omega t}, \\ \text{Sommerfeld's condition at infinity.} \end{aligned} \right. \tag{5.157}$$

This can be verified noting, for  $R \neq 0$ , that

$$\frac{1}{R} \frac{\partial^2}{\partial R^2} (R\Phi) \equiv -k^2 \Phi,$$

and for  $R \rightarrow 0$ , integrating equation (5.157) over a sphere of radius  $\varepsilon \rightarrow 0$  leads to

$$\begin{aligned}
 & - \lim_{\varepsilon \rightarrow 0} \iiint_{(\varepsilon)} \left[ (\Delta_{\bar{R}} + k^2) \Phi - Q_0 \delta(\bar{R}) e^{i\omega t} \right] d\bar{R} \\
 &= Q_0 \lim_{\varepsilon \rightarrow 0} \iiint_{(\varepsilon)} \left[ (\Delta_{\bar{R}} + k^2) \frac{e^{-ikR}}{4\pi R} + \delta(\bar{R}) \right] d\bar{R}, \\
 &= Q_0 \lim_{\varepsilon \rightarrow 0} \left[ \iint \text{grad}_{\bar{R}} \frac{e^{-ikR}}{4\pi R} \cdot d\bar{S} + k^2 \int_0^\varepsilon \frac{e^{-ikR}}{4\pi R} 4\pi R^2 dR + 1 \right], \\
 &= Q_0 \lim_{\varepsilon \rightarrow 0} \left[ 4\pi \varepsilon^2 \frac{\partial}{\partial \varepsilon} \frac{e^{-ik\varepsilon}}{4\pi \varepsilon} + k^2 \int_0^\varepsilon e^{-ikR} R dR + 1 \right], \\
 &= Q_0(-1 + 0 + 1) = 0.
 \end{aligned}$$

This result shows that the singularity  $\delta(\bar{R})$  in the right-hand side term of equation (5.157) is introduced by the factor  $\Delta\Phi$  in the left-hand side and not by the factor  $k^2\Phi$ .

To complete the discussion on the monopolar acoustic field given by equation (5.156), some of its properties are now given. The particle velocity associated to the pressure  $p$  is

$$\begin{aligned}
 v &= \frac{i}{k_0 \rho_0 c_0} \frac{\partial p}{\partial R} = i Q_0 k \left( 1 + \frac{1}{ikR} \right) e^{-ikR} e^{i\omega t}, \\
 v &\approx \frac{p}{\rho_0 c_0} + \frac{p}{ik_0 \rho_0 c_0 R}.
 \end{aligned} \tag{5.158}$$

The velocity field is the sum of two terms. The first term, called “far field”, is predominant for large values of  $R$  and it is in phase with the pressure. The second term, called “near field”, is predominant for small values of  $R$  and is out of phase with the pressure (it does not contribute to the energy flow).

That only the far field contributes to the energy flow is observed in the expression of the wave intensity

$$\begin{aligned}
 I &= \frac{1}{4} (p v^* + p^* v) = \frac{p p^*}{4 \rho_0 c_0} \left[ \left( 1 - \frac{1}{ikr} \right) + \left( 1 + \frac{1}{ikr} \right) \right] = \frac{p p^*}{2 \rho_0 c_0} \\
 &= \frac{\rho_0 c_0 k_0^2 Q_0^2}{2(4\pi)^2 R^2}.
 \end{aligned} \tag{5.159}$$

The power generated by the pulsating sphere is

$$\mathcal{P}_0 = 4\pi R^2 I = \frac{\rho_0 c_0 k_0^2 Q_0^2}{8\pi}. \quad (5.160)$$

The amplitude of the displacement required to obtain a given acoustic power  $\mathcal{P}_0$  is

$$\xi = \frac{|\bar{v}|}{\omega} = \frac{Q_0}{\omega 4\pi R^2} = \sqrt{\frac{c_0}{2\pi\rho_0}} \frac{\sqrt{\mathcal{P}_0}}{\omega^2 R^2}. \quad (5.161)$$

Equation (5.161) highlights a very general property of sources: small sources are not suitable sources at low frequencies, the surface displacements being always limited.

Note: the approach to verifying that the solution (5.156) satisfies equation (5.157) can also be applied for equivalent one- and two-dimensional problems. For a two-dimensional problem, one needs to verify that (suppressing the time factor)

$$0 = \lim_{\varepsilon \rightarrow 0} \iint [(\Delta + k^2)\Phi - \delta(\vec{R})] d\vec{R} = -1 + \lim_{\varepsilon \rightarrow 0} 2\pi \int_0^\varepsilon \frac{1}{R} \frac{\partial}{\partial R} \left( R \frac{\partial \Phi}{\partial R} \right) R dR.$$

To eliminate the singularity at the origin, the integral must be understood as a “principal value” (see Note 1 in section 6.2.3.4). On the condition that the first derivative of  $\Phi$  is an odd function (verified *a posteriori*), the latter result can be expressed as

$$0 = -1 + \lim_{\varepsilon \rightarrow 0} \pi \int_{-\varepsilon}^{\varepsilon} \frac{\partial}{\partial x} \left( |x| \frac{\partial \Phi}{\partial x} \right) dx = -1 + \lim_{\varepsilon \rightarrow 0} \pi |x| \frac{\partial \Phi}{\partial x} \Big|_{-\varepsilon}^{+\varepsilon},$$

$$\text{or } 1 = \lim_{\varepsilon \rightarrow 0} 2\pi \varepsilon \frac{\partial \Phi}{\partial \varepsilon},$$

or, replacing  $\varepsilon$  by  $R$ , as

$$\left. \frac{\partial \Phi}{\partial R} \right)_{R=0} = \lim_{R \rightarrow 0} \left( \frac{1}{2\pi R} \right),$$

$$\text{thus } \Phi_{R=0} = \lim_{R \rightarrow 0} \left( \frac{1}{2\pi} \log(kR) \right) = \lim_{R \rightarrow 0} \left[ \frac{i}{4} H_0^-(kR) \right]. \quad (5.162)$$

For a problem in one dimension, denoting  $X = x - x_0$ ,

$$\lim_{\varepsilon \rightarrow 0} \int_{-\varepsilon}^{\varepsilon} \frac{d^2\Phi}{dX^2} dX = \lim_{\varepsilon \rightarrow 0} \left[ \frac{d\Phi}{dX} \right]_{-\varepsilon}^{\varepsilon} = +1. \tag{5.163}$$

The gap at the origin of the first derivative of  $\Phi = -G = \frac{e^{-ik|x-x_0|}}{2ik}$  (equation (3.55)), given by

$$\lim_{\varepsilon \rightarrow 0} \left[ -\frac{\partial}{\partial(x-x_0)} \frac{e^{-ik|x-x_0|}}{2ik} \right]_{-\varepsilon}^{+\varepsilon},$$

is, as expected, equal to one.

5.2.5.2. *The dipolar field*

The amplitude of the dipolar acoustic field is given by equation (5.112). By denoting  $\vec{M}_0 = Q_0 d\vec{r}_0$  the dipolar moment  $M_0 = |\vec{M}_0|$ , the pressure is given by

$$p = -\rho_0 c_0 k_0^2 M_0 \left( 1 + \frac{1}{ik_0 R} \right) \frac{e^{-ikR}}{4\pi R} \cos\theta. \tag{5.164}$$

The components of the particle velocity are

$$v_R = \frac{i}{k_0 \rho_0 c_0} \frac{\partial p}{\partial R} = -k_0^2 M_0 \left( 1 + \frac{2}{ik_0 R} - \frac{2}{k_0^2 R^2} \right) \frac{e^{-ikR}}{4\pi R} \cos\theta e^{i\omega t}, \tag{5.165}$$

$$v_\theta = \frac{i}{k_0 \rho_0 c_0} \frac{\partial p}{\partial R} = -k_0^2 M_0 \left( 1 + \frac{2}{ik_0 R} - \frac{2}{k_0^2 R^2} \right) \frac{e^{-ikR}}{4\pi R} \cos\theta e^{i\omega t}. \tag{5.166}$$

The mean energy density

$$W = \frac{\rho_0}{2} \overline{v^2} + \frac{1}{2\rho_0 c_0^2} \overline{p^2} = \frac{\rho_0}{4} (v_r v_r^* + v_\theta v_\theta^*) + \frac{1}{4\rho_0 c_0^2} p p^* \tag{5.167}$$



can then be written as

$$W = \frac{\rho_0}{2} \left( \frac{k_0^2 M_0}{4\pi R} \right)^2 \left[ \cos^2 \theta + \frac{1}{2} \left( \frac{1}{k_0 R} \right)^2 + \frac{1}{2} \left( \frac{1}{k_0 R} \right)^4 (1 + 3 \cos^2 \theta) \right]. \quad (5.168)$$

The components of the intensity are given by

$$I_R = \frac{1}{4} (p v_r^* + p^* v_r) = \frac{\rho_0 c_0}{2} \left( \frac{k_0^2 M_0}{4\pi R} \right)^2 \cos^2 \theta = \frac{pp^*}{2\rho_0 c_0} \frac{1}{1 + \frac{1}{k_0^2 R^2}}, \quad (5.169)$$

$$I_\theta = I_\phi = 0.$$

Finally, the total power radiated by the dipole is given by

$$\begin{aligned} \mathcal{P}_0 &= \iint_{(4\pi)} I_R R^2 \sin \theta \, d\theta \, d\phi = 2\pi R^2 \frac{\rho_0 c_0}{2} \left( \frac{k_0^2 M_0}{4\pi R} \right)^2 2 \int_0^\pi \cos^2 \theta \, d(\cos \theta), \\ &= \frac{1}{24\pi} \rho_0 c_0 k_0^4 M_0^2. \end{aligned} \quad (5.170)$$

### 5.2.5.3. The quadripolar field

Two examples of quadripole are presented in Figure 5.13: the lateral quadripole (a) and the longitudinal quadripole (b). The main axes are taken so that some are parallel to the dipolar moments.

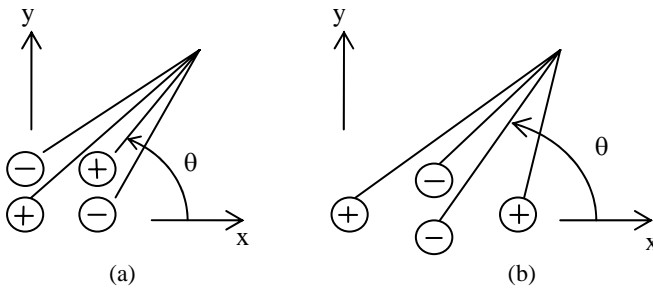

**Figure 5.13.** (a) Lateral quadripole, (b) Longitudinal quadripole

The dipolar pressure field is the gradient of the monopolar pressure field (section 5.2.2.3.3), i.e.

$$p_{\text{dip}} = -\frac{\partial p_{\text{monop}}}{\partial x_0} dx_0. \quad (5.171)$$

Similarly, the quadripolar pressure field is the gradient of the dipolar pressure field, namely,

– for the lateral quadripole:

$$\begin{aligned} p_{4p} &= -\frac{\partial p_{\text{dip}}}{\partial y_0} dy_0 = \frac{\partial^2 p_{\text{monop}}}{\partial x_0 \partial y_0} dx_0 dy_0 \\ &= -ik_0^3 \rho_0 c_0 Q_0 dx_0 dy_0 \frac{(x-x_0)(y-y_0)}{R^2} \left( 1 + \frac{3}{ik_0 R} - \frac{3}{k_0^2 R^2} \right) \frac{e^{-ikR}}{4\pi R} e^{i\omega t}, \end{aligned} \quad (5.172)$$

– for the longitudinal quadripole:

$$\begin{aligned} p_{4p} &= -\frac{\partial p_{\text{dip}}}{\partial x_0} dx_0 = \frac{\partial^2 p_{\text{monop}}}{\partial x_0^2} (dx_0)^2, \\ p_{4p} &= -ik_0^3 \rho_0 c_0 Q_0 (dx_0)^2 \\ &\quad \times \left[ \frac{(x-x_0)^2}{R^2} \left( 1 + \frac{3}{ik_0 R} - \frac{3}{k_0^2 R^2} \right) - \frac{1}{ik_0 R} + \frac{1}{k_0^2 R^2} \right] \frac{e^{-ikR}}{4\pi R} e^{i\omega t}, \end{aligned} \quad (5.173)$$

where  $\frac{x-x_0}{R} = \cos \theta$ .

#### 5.2.5.4. Field with axial symmetry

The diverging field with axial symmetry introduced in section 3.2.2, pressure field in the form of equation (5.93)

$$p = \sum_{n=0}^{\infty} A_n P_n(\cos \theta) h_n^-(kR) e^{i\omega t}, \quad (5.174)$$

can be written, considering equation (5.87), as

$$p = \sum_{n=0}^{\infty} i^{n+1} \frac{4\pi}{k_0} A_n R_n e^{i\omega t}, \quad (5.175)$$

$$\text{with } R_n = P_n(\cos\theta) \frac{e^{-ikR}}{4\pi R} f_n(ikR).$$

The factors

$$R_0 \approx \frac{e^{-ikR}}{4\pi R},$$

$$R_1 = \left(1 + \frac{1}{ik_0 R}\right) \frac{e^{-ikR}}{4\pi R} \cos\theta, \quad (5.176)$$

and:

$$R_2 = \frac{3}{2} \frac{e^{-ikR}}{4\pi R} \left[ \left(1 + \frac{3}{ik_0 R} - \frac{3}{k_0^2 R^2}\right) \cos^2\theta - \frac{1}{ik_0 R} + \frac{1}{ik_0^2 R^2} \right] - \frac{1}{2} \frac{e^{-ikR}}{4\pi R} \quad (5.177)$$

represent, respectively, a monopolar, dipolar and the superposition of a quadripolar and monopolar “component” of the acoustic pressure field, the next factor representing an “octupolar” component and so on.

This “interpretation” shows the model of Legendre’s polynomial series where the  $2n^{\text{th}}$ -pole is simply derived from the  $n^{\text{th}}$ -pole

$$2 \frac{dh_n(z)}{dz} = h_{n-1}(z) - h_{n+1}(z), \quad (5.178)$$

where the function  $h_n$  denotes the  $n^{\text{th}}$  order Hankel’s function ( $h_n^-$  or  $h_n^+$ ).

Note: frequently, the origin of the coordinates in the expression of  $R$

$$R = |\vec{r} - \vec{r}_0| = r \sqrt{1 - 2 \frac{\vec{r}}{r} \cdot \frac{\vec{r}_0}{r} + \left(\frac{r_0}{r}\right)^2}, \quad (5.179)$$

is taken at the vicinity of the elementary sources located at  $\vec{r}_0$  and the observation point is considered at a distance  $r \gg r_0$  (far field). Consequently, an asymptotic approximation of (5.179) can be made and is, at the 2<sup>nd</sup> order of the small quantity  $(r_0 / r)$ ,

$$R = |\vec{r} - \vec{r}_0| = r \left( 1 - \frac{\vec{r} \cdot \vec{r}_0}{r} + \frac{1}{2} \left[ \frac{r_0^2}{r^2} - \left( \frac{\vec{r} \cdot \vec{r}_0}{r} \right)^2 \right] \right). \quad (5.180)$$

*This page intentionally left blank*

## Chapter 6

# Integral Formalism in Linear Acoustics

This chapter is a turning point in this book as it introduces the integral formalism for problems in linear acoustics. The integral formalism is equivalent to the differential formalism used in the previous five chapters. The remaining development in this book uses the integral approach extensively and applies it to common situations in acoustics. Integral formalism is based on the decomposition of the acoustic field generated by extended primary sources (real) or secondary sources (reflections) into a sum of elementary fields (Green's functions) generated by (quasi-punctual) source elements. Green's functions therefore play an important role and, even though they have already been briefly introduced in sections 3.3, 3.4 and 5.2.5, the first part of this chapter is dedicated to their properties.

### **6.1. Considered problems**

#### **6.1.1. Problems**

The general problem considered, consisting of modeling a real situation in a domain (D) delimited by a surface (S) (eventually extended to infinity), is limited by the hypothesis of linear acoustics in weakly dissipative media initially at rest. The problem can be written, in the time domain, as:

$$\left[ \begin{aligned} & \left[ \Delta - \frac{1}{c^2} \frac{\partial^2}{\partial t^2} \right] p(\vec{r}, t) = -f, & \forall \vec{r} \in (D), & \forall t \in (t_1, \infty), & (6.1a) \\ & \frac{\partial p}{\partial n} + \frac{1}{c_0} \frac{\partial \beta}{\partial t} * p(\vec{r}, t) = U_0, & \forall \vec{r} \in (S), & \forall t \in (t_1, \infty), & (6.1b) \\ & p \text{ and } \frac{\partial p}{\partial t} \text{ are known } \forall \vec{r} \in (S), \text{ at } t = t_1. & & & (6.1c) \end{aligned} \right.$$

The equation of propagation (6.1a) is the equation (4.1), written in the form (4.13a). By making the hypothesis of null initial conditions,  $p(\vec{r}, t_1) = \frac{\partial p(\vec{r}, t_1)}{\partial t_1} = 0$ , the same problem in the frequency domain (obtained by Fourier transform) is

$$[\Delta + k^2] p(\vec{r}) = -f, \quad \forall \vec{r} \in (D), \tag{6.2a}$$

$$\left[ \frac{\partial}{\partial n} + ik_0 \beta(\vec{r}, \omega) \right] p(\vec{r}) = U_0, \quad \forall \vec{r} \in (S). \tag{6.2b}$$

For the sake of simplicity, one notation ( $p$  for example) denotes the quantities in both the time domain  $p(\vec{r}, t)$  and the frequency domain  $p(\vec{r}, \omega)$ . Also, the factor  $\beta$  (in equations (6.1) and (6.2)) denotes the specific admittance of the walls (S), the value of  $c$  remaining close to the adiabatic speed of sound  $c_0$  and the wavenumber  $k$  being given by equation (4.7). The factor  $U_0 / (ik_0 \rho_0 c_0)$  represents a vibration velocity imposed to part of (or to the entire) the wall of admittance  $\beta$ . The factor  $f$  is first approximated as the usual source term (1.61)

$$f = -\rho_0 \left[ \text{div} \vec{F} - \frac{\partial q}{\partial t} - \frac{\alpha}{C_p} \frac{\partial h}{\partial t} \right]. \tag{6.3}$$

Finally, the hypotheses made and presented in the introduction of Chapter 4 are adopted in the rest of the book.

### 6.1.2. Associated eigenvalues problem

In many cases, with a problem of the type (6.2) is associated an eigenvalue problem:

$$[\Delta + k_m^2(\omega)] \psi_m(\vec{r}, \omega) = 0, \quad \forall \vec{r} \in (D), \tag{6.4a}$$

$$\left[ \frac{\partial}{\partial n} + ik_0 \zeta(\vec{r}, \omega) \right] \psi_m(\vec{r}, \omega) = 0, \quad \forall \vec{r} \in (S), \tag{6.4b}$$

where  $\zeta$  denotes a small admittance (null or equal to  $\beta$ ). The solutions to this problem form a basis in respect of which the solutions of equation (6.2) can be expanded.

The notions introduced in the following sections are to be interpreted as distributions. However, for the sake of simplicity, the forthcoming developments are presented in such manner that these functions can be interpreted as distributions or ordinary functions.

### 6.1.3. Elementary problem: Green's function in infinite space

In accordance with the linearity of the equation of propagation, the acoustic pressure field solution to the problems (6.1) and (6.2) can be written as the superposition of elementary fields generated by each source element. The resulting field is then defined by an integral of the elementary field, for example:

$$p(\vec{r}, t) = \iiint_{(D)} d\vec{r}_0 \int_{t_i}^{\infty} dt_0 G(\vec{r}, \vec{r}_0; t, t_0) f(\vec{r}_0, t_0) .$$

Each element is represented by a Green's function (monopolar field) of the variables  $(\vec{r} - \vec{r}_0)$  and  $(t - t_0)$ . The integral is nothing more than a convolution expressing the acoustic field generated by the sources  $f$ , but also the field from the image sources if one considers, to a certain degree, the presence of reflective boundaries.

In most cases, the boundary effect is treated by considering that each boundary element reacts under an incident wave and radiates back into the fluid medium, behaving just as a source which energy is extracted from the incident wave. Its characteristics depend on the active vibratory state of the wall ( $U_0$ ) and on the material characteristics of the wall ( $\beta$ ). Again, the contribution of this reaction is introduced as a convolution integral, but here the "boundary source" is presented as a double layer of "sources", a monopolar one and a dipolar one.

These qualitative descriptions are demonstrated in the following sections. They stress the importance given to monopolar and dipolar acoustic fields when solving the aforementioned problems. Also, the above discussion underlines the fact that one's choice is limited to that of the boundary conditions imposed on the Green's function that satisfies the governing equation (6.5).

It is therefore important to introduce the principal properties of Green's functions before presenting the integral formalism of problems at boundaries.



The Green's function is a solution to the following non-homogenous equation of propagation in the time domain:

$$\left( \Delta - \frac{1}{c^2} \frac{\partial^2}{\partial t^2} \right) G(\vec{r}, \vec{r}_0; t, t_0) = -\delta(\vec{r} - \vec{r}_0) \delta(t - t_0), \quad (6.5)$$

and a solution to the Helmholtz equation in the frequency domain:

$$[\Delta + k^2] G(\vec{r}, \vec{r}_0) = -\delta(\vec{r} - \vec{r}_0) e^{-i\omega t_0}. \quad (6.6)$$

The solutions to these equations in an infinite space (Sommerfeld's condition) are given by equations (3.38), (3.43) and (3.44) for three-dimensional fields, by equations (3.49) and (3.50) for two-dimensional fields, and by equations (3.54) and (3.55) for fields in one dimension.

The Green's function is invariant with respect to the permutation of the variables  $\vec{r}$  and  $\vec{r}_0$ , and presents a singularity at  $\vec{r} = \vec{r}_0$ . This singularity is of the form  $1/|\vec{r} - \vec{r}_0|$  in a 3D-space,  $\log |\vec{r} - \vec{r}_0|$  in a 2D-space (5.162), and as in equation (5.163) for a 1D-space.

#### 6.1.4. Green's function in finite space

The Green's function is chosen such that it satisfies some boundary conditions adapted to the considered problem. A few examples are given in this section.

##### 6.1.4.1. Green's function in semi-infinite space (method of the image source)

The considered domain (D) is a semi-infinite space  $z > 0$ , delimited by a plane assumed perfectly rigid at  $z = 0$  (Figure 6.1).

A Green's function in the time domain is given by

$$\frac{\delta\left(\frac{R}{c_0} - \tau\right)}{4\pi R}$$

and in the frequency domain by

$$\frac{e^{-ikR}}{4\pi R},$$

where  $R = |\vec{r} - \vec{r}_0|$  denotes the distance between the punctual source at  $\vec{r}_0 \in (D)$  and the receiving point at  $\vec{r} \in (D)$ .

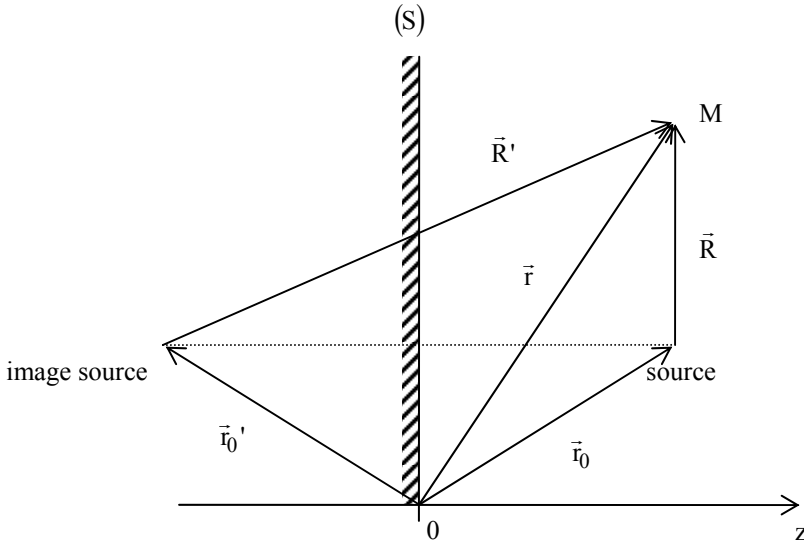

**Figure 6.1** Green's function in the domain (D) ( $z > 0$ ); source  $\vec{r}_0$  and image source  $\vec{r}_0'$  with respect to the reflecting plane  $z = 0$

However, the sum of this Green's function in the time domain, particularly in the frequency domain, with the function  $\delta\left(\frac{R'}{c_0} - \tau\right) / 4\pi R'$ , and particularly  $e^{-ikR'} / 4\pi R'$  ( $R' = |\vec{r} - \vec{r}_0'|$  where  $\vec{r}_0'$  represents the position of the image source with respect to the reflective plane at  $z = 0$ ), constitutes a new Green's function in the domain (D):

$$G(\vec{r}, \vec{r}_0; t, t_0) = \frac{\delta\left(\frac{R}{c_0} - \tau\right)}{4\pi R} + \frac{\delta\left(\frac{R'}{c_0} - \tau\right)}{4\pi R'}, \quad (6.7a)$$

$$G(\vec{r}, \vec{r}_0) = e^{-i\omega t_0} \left[ \frac{e^{-ikR}}{4\pi R} + \frac{e^{-ikR'}}{4\pi R'} \right]. \quad (6.7b)$$

Since  $R'$  is never null in the domain  $(D)$ , the functions (6.7) have a unique singularity at  $R = 0$  in  $(D)$  and therefore satisfy, respectively, equations (6.5) and (6.6) (see, in section 5.2.5.1, the comment on the singularity at  $\delta(\vec{r})$ ). Moreover, these functions satisfy Neumann's condition  $\partial G / \partial z_0 = 0$  at  $z_0 = 0$  as the derivatives of these two functions (the sum of which is the Green's function) are of opposite sign at  $z_0 = 0$ . This can be verified denoting

$$R = \sqrt{(x - x_0)^2 + (y - y_0)^2 + (z - z_0)^2}, \tag{6.8a}$$

$$R' = \sqrt{(x - x_0)^2 + (y - y_0)^2 + (z + z_0)^2}. \tag{6.8b}$$

At the boundary  $z_0 = 0$ , the Green's functions (6.7) become respectively

$$G(\vec{r}, \vec{r}_0; t, t_0) = \frac{\delta\left(\frac{R_0}{c_0} - \tau\right)}{2\pi R_0}, \tag{6.9a}$$

$$G(\vec{r}, \vec{r}_0) = e^{-i\omega t_0} \frac{e^{-ikR_0}}{2\pi R_0}, \tag{6.9b}$$

where  $R_0 = \sqrt{(x - x_0)^2 + (y - y_0)^2 + z^2}$ .

Note: the Green's functions that satisfy Dirichlet's condition at  $z_0 = 0$  can be written as

$$G(\vec{r}, \vec{r}_0; t, t_0) = \frac{\delta\left(\frac{R}{c_0} - \tau\right)}{4\pi R} - \frac{\delta\left(\frac{R'}{c_0} - \tau\right)}{4\pi R'}, \tag{6.10a}$$

$$G(\vec{r}, \vec{r}_0) = e^{-i\omega t_0} \left[ \frac{e^{-ikR}}{4\pi R} - \frac{e^{-ikR'}}{4\pi R'} \right]. \tag{6.10b}$$

A similar note could be made about Green's functions in a 2D- or 1D-space.

#### 6.1.4.2. Harmonic Green's function in finite one-dimensional spaces

A harmonic perturbation generated at the abscissa  $z_0$  propagates in a one-dimensional limited space in the interval  $[z = a, z = a + \ell]$  with  $z_0 \in [a, a + \ell]$ . The Green's function that satisfies the mixed boundary conditions represents the

amplitude of the considered field at any given point  $z \in [a, a + \ell]$ . It is a solution to the following problem:

$$\left( \frac{\partial^2}{\partial z^2} + k^2 \right) G(z, z_0) = -\delta(z, z_0), \quad z \in (a, a + \ell), \tag{6.11a}$$

$$\left( \frac{\partial}{\partial z} - ik_0 \zeta_a \right) G = 0, \quad z = a, \tag{6.11b}$$

$$\left( \frac{\partial}{\partial z} + ik_0 \zeta_\ell \right) G = 0, \quad z = \ell + a, \tag{6.11c}$$

where the reflection coefficients  $R_{a,\ell} = e^{-2i\alpha_{a,\ell}}$  are associated with the specific admittances  $\zeta_{a,\ell}$  by

$$\zeta_{a,\ell} = \frac{1 - R_{a,\ell}}{1 + R_{a,\ell}} = \frac{1 - e^{-2i\alpha_{a,\ell}}}{1 + e^{-2i\alpha_{a,\ell}}} = i \operatorname{tg}(\alpha_{a,\ell}). \tag{6.12}$$

Following the method presented in section 4.2.1, the Green’s function satisfying the system of equations (6.11) represents the amplitude of the acoustics field at  $z$  resulting from the superposition of the field generated by the real source at  $z_0$  and the fields generated by all the image sources associated with the multiple reflections on the “walls” (at  $a$  and  $a + \ell$ ). The attenuation and phase differences due to the reflections are considered herein. All these sources are marked in Figure 6.2 by crosses.

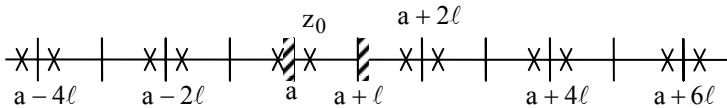

**Figure 6.2.** Real source at  $z_0$  and image sources in the  $[a, a + \ell]$  space

These image sources can be separated into two categories: those located on the right-hand side of the image walls, and those located on the left-hand side of the image walls. The former are located at

$$z_0 + 2v\ell, \quad v \text{ being an integer } v \in ]-\infty, +\infty[, \tag{6.13}$$

and the ratio of their intensity to the intensity of the real source is

$$(R_a R_\ell)^{|v|}.$$

The latter are located at

$$-z_0 + 2a + 2v\ell,$$

and their relative amplitude is

$$R_a^{-\frac{v}{|v|}} (R_a R_\ell)^{|v|}.$$

The Green's function  $G$  can then be written, according to equation (3.55), as

$$G = \sum_{v=-\infty}^{+\infty} \frac{(R_a R_\ell)^{|v|}}{2ik} \left[ e^{-ik|z-z_0-2v\ell|} + R_a^{-\frac{v}{|v|}} e^{-ik|z+z_0-2a-2v\ell|} \right], \quad (6.14)$$

where only the factor  $v=0$  is responsible for the  $-1$  step of the first derivative in the considered domain  $[a, a + \ell]$  and where  $k$  remains close to  $k_0$ .

By using the properties of geometric series, one can easily show that equation (6.14) can also be written as

$$G = \frac{-1}{k \sin(k\ell + \alpha_a + \alpha_\ell)} \cos[k(z_< - a) + \alpha_a] \cos[k(z_> - a - \ell) - \alpha_\ell], \quad (6.15)$$

where  $z_> = z$  and  $z_< = z_0$  if  $z > z_0$  and the inverse if  $z < z_0$ .

This result can be verified as follows:

i)  $\lim_{\varepsilon \rightarrow 0} \left. \frac{\partial G}{\partial z} \right)_{z_0 - \varepsilon}^{z_0 + \varepsilon} = -1$  (step of the first derivative of  $G$ ) and  $G$  is a solution to

equation (6.11a) for  $z \neq z_0$ ; consequently it is a solution to this equation  $\forall z \in [a, a + \ell]$ ;

ii) for  $z = a + \ell \geq z_0$  or  $z_0 = a + \ell \geq z$ ,  $\frac{\partial G}{\partial z} = -k \operatorname{tg}(\alpha_\ell) G \approx -ik_0 \zeta_\ell G$ , and for  $z = a \leq z_0$  or  $z_0 = a \leq z$ , the boundary conditions (6.11b) is also verified;

iii) finally,  $G(z, z_0) \equiv G(z_0, z)$  (reciprocity of the Green's function).

One can obtain the same expression as in equation (6.15) of the Green's function by directly solving the system of equation (6.11) as follows:

– let  $g_1(z)$  and  $g_2(z)$  be two independent solutions (with non-null Wronskian  $W_g(z)$ ), to the homogeneous equation associated with equation (6.11a) satisfying the boundary conditions (6.11b) and (6.11c); the Green's function solution to the problem (6.11) is then

$$G(z, z_0) = -g_2(z) \int_a^z \frac{g_1(\zeta) \delta(\zeta - z_0)}{W_g(\zeta)} d\zeta - g_1(z) \int_z^{a+\ell} \frac{g_2(\zeta) \delta(\zeta - z_0)}{W_g(\zeta)} d\zeta, \quad (6.16)$$

where  $W_g(z) = g_1(z)g_2'(z) - g_2(z)g_1'(z)$  with  $g_i'(z) = \partial g_i / \partial z$ ,  $i = 1, 2$ .

This solution leads directly to the same result (6.15).

Note: in the particular case where  $\alpha_a = \alpha_\ell = 0$  (Neumann's condition at  $z = a$  and  $z = a + \ell$ ), the function  $g(z, z_0)$  in the domain  $[a, a + \ell]$ , which is extended to ensure even parity of the function over a domain  $2\ell$  can be developed in Fourier series as:

$$G(z, z_0) = \sum_m \frac{2 - \delta_{m0}}{\ell} \frac{\cos(m\pi z_0 / \ell) \cos(m\pi z / \ell)}{(m\pi / d)^2 - k^2}. \quad (6.17)$$

#### 6.1.4.3. Green's function in closed spaces (same boundary conditions for the eigenfunctions as for the Green's function)

In a closed domain (D), delimited by a surface (S), it is useful to find a Green's function that satisfies some boundary conditions governed by a small specific admittance  $\zeta(\vec{r}, \omega)$  in the frequency domain. The associated eigenvalue problem given by equations (6.4), where the Green's functions and the eigenfunctions satisfy the same boundary conditions, has a set of solutions  $\psi_m(\vec{r}, \omega)$  ( $m$  being a triple index) constituting a basis of the considered space with respect to which the Green's function can be expanded

$$G(\vec{r}, \vec{r}_0) = \sum_m A_m \psi_m(\vec{r}). \quad (6.18)$$

This Green's function satisfies the same boundary condition as the one imposed on the eigenfunctions  $\psi_m$

$$\frac{\partial G}{\partial n} + ik_0 \zeta G = 0 \text{ over (S)}.$$

One needs to express the expansion coefficients  $A_m$  so that the Green's function satisfies Helmholtz equation (6.6)

$$[\Delta + k^2] \sum_m A_m \psi_m(\vec{r}) = -\delta(\vec{r} - \vec{r}_0) \quad (6.19)$$

where  $e^{j\omega t_0}$  is temporarily suppressed and where  $m$  denotes a set of three quantum numbers.

By multiplying each term of equation (6.19) by the eigenfunction  $\psi_{q_2}(\vec{r})$  and integrating over the whole domain, one obtains (considering that  $\Delta \psi_m = -k_m^2 \psi_m$ )

$$\sum_{m=0}^{\infty} (k^2 - k_m^2) A_m \iiint_{(D)} \psi_q(\vec{r}) \psi_m(\vec{r}) d\vec{r} = -\psi_q(\vec{r}_0).$$

The orthogonality of the eigenfunctions

$$\iiint_{(D)} \psi_q(\vec{r}) \psi_m(\vec{r}) d\vec{r} = \delta_{qm},$$

leads directly to

$$A_m = \frac{\psi_m(\vec{r}_0)}{k_m^2 - k^2},$$

and finally to

$$G(\vec{r}, \vec{r}_0) = \sum_m \frac{\psi_m(\vec{r}_0)}{k_m^2 - k^2} \psi_m(\vec{r}). \quad (6.20)$$

A three-dimensional analysis of this expression (as in section 6.1.4.2) reveals that this Green's function represents the velocity potential generated in the domain (D) by a punctual source of this domain and by all the image sources associated with the multiple reflections in the cavity.

The corresponding Green's function in the time domain is obtained by the inverse Fourier transform and integrating by the method of residues. It is therefore necessary to know the functions  $k_m^2(\omega)$  and  $k^2(\omega)$  that are complex functions depending, respectively, on the boundary conditions and the dissipative effects during the propagation between two reflections.

Since the imaginary parts of  $k_m^2(\omega)$  and  $k^2(\omega)$  (weak dissipation) remain much smaller than the real parts, the roots of the denominator of equation (6.20) are obtained by writing that

$$0 = k_m^2 - k^2 = [k_{0m}(1 + \varepsilon_{1m} + i\varepsilon_{2m})]^2 - [k_0(1 + \eta_1 + i\eta_2)]^2,$$

or

$$k_{0m}^2(1 + 2\varepsilon_{1m} + 2i\varepsilon_{2m}) - k_0^2(1 + 2\eta_1 + 2i\eta_2), \quad (6.21)$$

where the factors  $\varepsilon_{1m}$  and  $\varepsilon_{2m}$  denote the real and imaginary parts of the corrections terms to add to the eigenvalues  $k_{0m}$  of Neumann's problem ((6.4) where  $\zeta = 0$ ), leading to the eigenvalues of the problem (6.4) with  $\zeta \neq 0$ . The factors  $\eta_1$  and  $\eta_2$  denote the real and imaginary parts of the correction terms to add to the wavenumber  $k_0$  in non-dissipative fluids accounting for the dissipation effect and leading to the associated wavenumber  $k$  ( $k = k_a$  in equation (2.86)).

The solution to equation (6.21) is given, as a first approximation, by

$$k_0^2(1 + 2\eta_1) = k_{0m}^2(1 + 2\varepsilon_{1m}) \text{ or } k_0 \approx \pm k_{0m}, \quad (6.22)$$

$$\text{and } k_0^2\eta_2 = k_{0m}^2\varepsilon_{2m} \text{ or } \eta_2 \approx \varepsilon_{2m}. \quad (6.23)$$

Thus the poles of the right-hand side term of equation (6.20) of the Green's function  $G(\vec{r}, \vec{r}_0)$  are, for a given pulsation  $\omega$ ,

$$\omega_m^\pm \approx \pm\omega_m + i\gamma_m \quad (6.24)$$

where  $\omega_m \approx \text{Re}[k_m]$  (equation (6.22)),

and where the expression of  $\gamma_m$  is such that equation (6.23) is satisfied given equation (6.22). An example of this derivation is given in the forthcoming section. Examples of the expressions of wavenumbers and eigenfunctions are given in Chapters 4 and 5. A complete study in such realistic situations would show that  $\gamma_m$  is a positive number (compare section 9.2.3, equations (9.27) to (9.29)).

Finally, the Green's function in the time domain is

$$G(\vec{r}, t; \vec{r}_0, t_0) \approx \frac{c_0^2}{2\pi} \sum_m \psi_m(\vec{r}_0) \psi_m(\vec{r}) \int_{-\infty}^{+\infty} \frac{e^{i\omega(t-t_0)} d\omega}{(\omega - \omega_n^+) (\omega - \omega_n^-)}. \quad (6.25)$$



The poles are located above the real axis and the integration contour is chosen as shown in Figure 6.3 depending on the sign of  $(t - t_0)$  so that the integral in equation (6.25) becomes

$$\int_{-\infty}^{\infty} \frac{e^{i\omega(t-t_0)} d\omega}{-(\omega - \omega_n^+)(\omega - \omega_n^-)} = -2i\pi [\text{Res}(\omega_n^+) + \text{Res}(\omega_n^-)] U(t - t_0), \quad (6.26)$$

where  $\text{Res}(\omega_n^+)$  and  $\text{Res}(\omega_n^-)$  are the residues associated to the poles,

$$\text{Res}(\omega_n^\pm) = \pm \frac{e^{i\omega_n^\pm(t-t_0)}}{\omega_n^+ - \omega_n^-}. \quad (6.27)$$

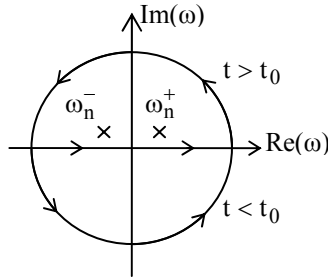

**Figure 6.3.** Poles and integration contour to calculate the Fourier transform of the Green’s function

The Green’s function can finally be written as

$$G(\vec{r}, t; \vec{r}_0, t_0) = c_0^2 U(t - t_0) \sum_{m=0}^{\infty} \psi_m(\vec{r}_0) \psi_m(\vec{r}) e^{-\gamma_m(t-t_0)} \frac{\sin \omega_m(t - t_0)}{\omega_m}, \quad (6.28)$$

where the Heaviside function  $U(t - t_0)$  accounts for the “causality principle” according to which the recorded field at the instant  $t$  cannot precede the cause (impulse signal emitted at  $t_0$ ). The imaginary part  $\gamma_m$  of the poles is responsible for the complete attenuation in time of the field.

Note 1: the source radiates an impulse signal with a continuous and “flat” frequency spectrum and the receiver “sees” a discontinuous spectrum that is the superposition of the direct and reflected pulses.

Note 2: the Green's function, which is the solution to the following problem in the frequency domain:

$$(\Delta + k^2)G(\vec{r}, \vec{r}_0) = -\delta(\vec{r} - \vec{r}_0), \text{ in } (D), \quad (6.29a)$$

$$\left[ \frac{\partial}{\partial n} + ik_0 \zeta \right] G(\vec{r}, \vec{r}_0) = 0, \text{ over } (S), \quad (6.29b)$$

where (D) represents here a cylindrical domain limited by the surface (S) of main axis  $z$  with  $z \in [a, a + \ell]$  (Figure 6.4), can also be written in the form as in equation (6.20) where  $m$  denotes the triple quantum index: couple  $(\mu, \nu)$  as in equation (5.46) and  $m_z$ .

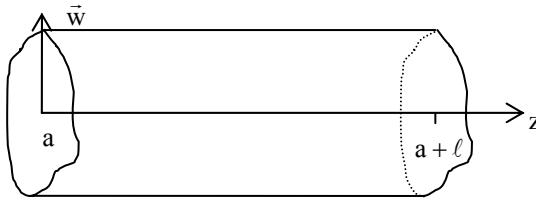

**Figure 6.4.** Cylindrical closed space

However, the Green's function can be expanded on the basis of the eigenfunctions  $\psi_{\mu\nu}(\vec{w})$  of the cylinder that satisfy the boundary condition (6.29b) and can be written as  $e^{\pm i\mu\varphi} J_\mu(k_{w\mu\nu} \vec{w})$  if the cross-section of the tube is circular. The expansion coefficients then depend on the variable  $z$ :

$$G(\vec{r}, \vec{r}_0) = \sum_{\mu, \nu=0}^{\infty} g_{\mu\nu}(z, z_0) \psi_{\mu\nu}(\vec{w}_0) \psi_{\mu\nu}(\vec{w}), \quad (6.30)$$

where the coefficients are denoted  $g_{\mu\nu} \psi_{\mu\nu}$  for the sake of simplicity.

The substitution of the solution (6.30) into equations (6.29) gives

$$\sum_{\mu, \nu} \psi_{\mu\nu}(\vec{w}_0) \left[ \Delta_{\vec{w}} + \frac{\partial^2}{\partial z^2} + k^2 \right] g_{\mu\nu}(z, z_0) \psi_{\mu\nu}(\vec{w}) = -\delta(\vec{w} - \vec{w}_0) \delta(z - z_0). \quad (6.31)$$

By using the orthogonality between the eigenfunctions  $\psi_{\mu\nu}$ , and since  $\Delta_{\vec{w}} \psi_{\mu\nu}(\vec{w}) = -k_{w\mu\nu}^2 \psi_{\mu\nu}(\vec{w})$  where  $k_{w\mu\nu}$  denotes the eigenvalues associated to the eigenfunctions  $\psi_{\mu\nu}$  (as for equations (6.19) and (6.20)), one obtains

$$\left[ \frac{\partial^2}{\partial z^2} + k_{z\mu\nu}^2 \right] g_{\mu\nu}(z, z_0) = -\delta(z - z_0), \quad z \in [a, a + \ell], \quad (6.32a)$$

with  $k_{z\mu\nu}^2 = k^2 - k_{\mu\nu}^2$ .

The solution must satisfy the following boundary conditions:

$$\left( \frac{\partial}{\partial z} - ik_0 \zeta_a \right) g_{\mu\nu} = 0 \quad \text{at } z = a, \quad (6.32b)$$

$$\left( \frac{\partial}{\partial z} + ik_0 \zeta_\ell \right) g_{\mu\nu} = 0 \quad \text{at } z = a + \ell. \quad (6.32c)$$

The problem (6.32) is nothing other than the problem (6.11) with

$$\zeta_{a,\ell} = \frac{k_{z\mu\nu}}{k} \frac{1 - R_{a,\ell}}{1 + R_{a,\ell}} = \frac{k_{z\mu\nu}}{k} \frac{1 - e^{-2i\alpha_{a,\ell}}}{1 + e^{-2i\alpha_{a,\ell}}} = i \frac{k_{z\mu\nu}}{k} \operatorname{tg} \alpha_{a,\ell} \quad (6.33)$$

where the ratio  $k_{z\mu\nu}/k$  is the angle of incidence of the propagative modes. The solution to such problem is written as (6.15)

$$g_{\mu\nu}(z, z_0) = \frac{-\cos[k_{z\mu\nu}(z < -a) + \alpha_a] \cos[k_{z\mu\nu}(z > -a - \ell) - \alpha_\ell]}{k_{z\mu\nu} \sin(k_{z\mu\nu} \ell + \alpha_a + \alpha_\ell)}, \quad (6.34)$$

where  $z_> = z$  and  $z_< = z_0$  if  $z > z_0$  and inversely if  $z < z_0$ .

Another alternative form of the solution (6.30) can be obtained by presenting the solution as an expansion on the basis of eigenfunctions that do not depend on the variable  $z$ , the expansion coefficients depending then on the variable  $\vec{w}$ .

#### 6.1.4.4. Green's function in closed spaces (different boundary conditions for the eigenfunctions and Green's function)

In many cases, it is advantageous to express, in the frequency domain, the Green's function satisfying mixed boundary conditions, in the form

$$\left[ \frac{\partial}{\partial n} + ik_0 \zeta \right] G(\vec{r}, \vec{r}_0) = 0, \quad \text{over } (S). \quad (6.35)$$

The Green's function is then expanded on the basis of functions that satisfy Neumann's condition at the limits of the domain

$$\frac{\partial}{\partial \mathbf{n}} \Phi_m = 0 \text{ over } (\mathbf{S}). \quad (6.36)$$

The Green's function can then be written as

$$G(\bar{\mathbf{r}}, \bar{\mathbf{r}}_0) = \sum_m g_m(\bar{\mathbf{r}}_0) \Phi_m(\bar{\mathbf{r}}) . \quad (6.37)$$

It is not possible to write, *a priori*, that

$$\frac{\partial G}{\partial \mathbf{n}} = \sum_m g_m \frac{\partial \Phi_m}{\partial \mathbf{n}} \text{ over } (\mathbf{S}),$$

since this equality does not hold as the conditions that are satisfied by, respectively, the Green's function  $G$  (6.35) and the eigenfunction  $\Phi_m$  (6.36) are not necessarily the same. One barely needs any mathematical formalism to verify that the derivative of the series is not equal to the sum of the derivative of each term of the series. This is also true, *a fortiori*, for the second-order derivatives. Therefore, it is more appropriate to associate another expansion to the Laplacian of the Green's function:

$$\Delta G = \sum_m \alpha_m(\bar{\mathbf{r}}_0) \Phi_m(\bar{\mathbf{r}}). \quad (6.38)$$

However, all these choices are, in some respect, arbitrary and during the analysis of the velocity field associated with the Green's function at the vicinity of the walls, one still needs to use equation (6.35) to replace the operator  $\partial/\partial \mathbf{n}$  by the factor  $(-ik_0\zeta)$ .

According to Appendix A2 to Chapter 4, and assuming that the eigenfunctions  $\Phi_m$  are real, the expansion coefficients in equations (6.37) and (6.38) are given by the following scalar products

$$g_m = \iiint_{(D)} G(\bar{\mathbf{r}}', \bar{\mathbf{r}}_0) \Phi_m(\bar{\mathbf{r}}') d\mathbf{r}' \quad (6.39a)$$

$$\text{and } \alpha_m = \iiint_{(D)} \Delta_{\bar{\mathbf{r}}'} G(\bar{\mathbf{r}}', \bar{\mathbf{r}}_0) \Phi_m(\bar{\mathbf{r}}') d\mathbf{r}' . \quad (6.39b)$$

The expression of  $\alpha_m$  can then be modified by writing that

$$\begin{aligned}
 \alpha_m &= \iiint \operatorname{div} [\operatorname{grad} G(\bar{r}', \bar{r}_0)] \Phi_m(\bar{r}') d\bar{r}' \\
 &= \iiint \operatorname{div} [\Phi_m(\bar{r}') \operatorname{grad} G(\bar{r}', \bar{r}_0)] d\bar{r}' \\
 &\quad - \iiint \operatorname{grad} G(\bar{r}', \bar{r}_0) \operatorname{grad} \Phi_m(\bar{r}') d\bar{r}' \\
 &= \iiint \operatorname{div} [\Phi_m(\bar{r}') \operatorname{grad} G(\bar{r}', \bar{r}_0)] d\bar{r}' \\
 &\quad - \iiint \operatorname{div} [G(\bar{r}', \bar{r}_0) \operatorname{grad} \Phi_m(\bar{r}')] d\bar{r}' \\
 &\quad + \iiint G(\bar{r}', \bar{r}_0) \operatorname{div} [\operatorname{grad} \Phi_m(\bar{r}')] d\bar{r}' \\
 &= \iiint [\Phi_m(\bar{r}') \operatorname{grad} G(\bar{r}', \bar{r}_0) - G(\bar{r}', \bar{r}_0) \operatorname{grad} \Phi_m(\bar{r}')] d\bar{r}' \\
 &\quad + \iint_{(D)} G(\bar{r}', \bar{r}_0) \Delta_{\bar{r}'} \Phi_m(\bar{r}') d\bar{r}',
 \end{aligned}$$

or, considering equations (6.35), (6.36), and (6.39a) and that  $\Delta_{\bar{r}'} \Phi_m(\bar{r}') = -k_m^2 \Phi_m(\bar{r}')$ ,

$$\alpha_m(r_0) = -ik_0 \iint_{(S)} \zeta(\bar{r}') G(\bar{r}', \bar{r}_0) \Phi_m(\bar{r}') d\bar{r}' - k_m^2 g_m(r_0). \quad (6.40)$$

The substitution of equations (6.37) and (6.38) into equation (6.6), and multiplying each term by any eigenfunction of the basis and integrating over the whole domain, gives

$$\begin{aligned}
 \iint_{(D)} d\bar{r} \Phi_m(\bar{r}) \sum_{\mu} \left[ -ik_0 \iint_{(S)} \zeta G \Phi_{\mu} d\bar{r}' + (k^2 - k_{\mu}^2) g_{\mu}(\bar{r}_0) \right] \Phi_{\mu}(\bar{r}) \\
 = - \iint_{(D)} \delta(\bar{r} - \bar{r}_0) \Phi_m(\bar{r}) d\bar{r}.
 \end{aligned}$$

The orthogonality properties of the (assumed) ortho-normal eigenfunctions lead to

$$-ik_0 \iint_{(S)} \zeta G \Phi_m d\bar{r}' + (k^2 - k_m^2) g_m(\bar{r}_0) = -\Phi_m(\bar{r}_0),$$

or, substituting equation (6.37), to

$$g_m(\bar{r}_0) = \frac{1}{k_m^2 - k^2} \left[ \Phi_m(\bar{r}_0) - ik_0 \sum_{\nu} g_{\nu}(\bar{r}_0) \iint_{(S)} \zeta(\bar{r}') \Phi_{\nu}(\bar{r}') \Phi_m(\bar{r}') d\bar{r}' \right]. \quad (6.41)$$

By separating the terms in the sum for which  $v \neq m$  and the term where  $v = m$ , one obtains

$$g_m(\vec{r}_0) = \frac{\left[ \Phi_m(\vec{r}_0) - ik_0 \sum_{v \neq m} g_v(\vec{r}_0) \iint_{(S)} \zeta \Phi_v \Phi_m d\vec{r}' \right]}{k_m^2 - k^2 + ik_0 \iint_{(S)} \zeta \Phi_m^2 d\vec{r}'} . \quad (6.42)$$

This expression reveals an inter-modal coupling between the  $m^{\text{th}}$  mode and the modes ( $v \neq m$ ) associated with attenuation and reaction due to the complex nature of  $\zeta$ . Also, for  $\zeta = 0$ ,  $g_m(\vec{r}_0)$  takes the form of equation (6.20).

Frequently, the inter-modal coupling factors

$$\iint_{(S)} \zeta \Phi_v \Phi_m d\vec{r}', \quad v \neq m$$

are negligible in equation (6.42). In such cases, the expansion coefficients  $g_m$  become

$$g_m(\vec{r}_0) \approx \frac{\Phi_m(\vec{r}_0)}{k_m^2 - k^2 + ik_0 \iint_{(S)} \zeta \Phi_m^2 d\vec{r}'} . \quad (6.43)$$

Consequently, the approximate expression of the Green's function is

$$G(\vec{r}, \vec{r}_0) = \sum_m \frac{\Phi_m(\vec{r}_0)}{k_m^2 - k^2 + ik_0 \iint_{(S)} \zeta \Phi_m^2 d\vec{r}'} \Phi_m(\vec{r}) . \quad (6.44)$$

If necessary, the comment following equation (6.38) could be considered.

### Example

In the particular case where  $\zeta$  denotes the specific admittance associated with the effects of viscothermal boundary layers (3.10),

$$ik_0 \iint_{(S)} \zeta \Phi_m^2 d\vec{r} = i\sqrt{i} \left( \frac{\omega}{c_0} \right)^{3/2} \varepsilon_{vhm} ,$$

$$\text{where } \varepsilon_{vhm} = \iint_{(S)} \left[ \left( 1 - \frac{k_{1m}^2}{k_0^2} \right) \sqrt{\ell'_v} + (\gamma - 1) \sqrt{\ell'_h} \right] \Phi_m^2 d\vec{r}'$$

and considering the visco-thermal dissipation during propagation

$$k^2 = \frac{\omega^2}{c_0^2} \left( 1 - i \frac{\omega}{c_0} \ell_{vh} \right),$$

the denominators of the series contained in equation (6.44) become

$$k_m^2 - \frac{\omega^2}{c_0^2} \left( 1 - i \frac{\omega}{c_0} \ell_{vh} \right) + i \sqrt{i} \left( \frac{\omega}{c_0} \right)^{3/2} \varepsilon_{vhm}. \quad (6.45)$$

The roots of this function are given by

$$\omega = \pm \omega_m + i \gamma_m, \quad (6.46)$$

$$\text{where } \omega_m \approx \pm c_0 k_m \quad (6.47a)$$

$$\text{and } \gamma_m \approx \frac{\sqrt{c_0 \omega_m}}{2\sqrt{2}} \varepsilon_{vhm} + \frac{\omega_m^2}{2c_0} \ell_{vh}. \quad (6.47b)$$

The latter solution expressed by equations (6.46) and (6.57) can be verified by ignoring the term in  $\gamma_m$  in the real part of the solution and the terms in  $\gamma_m^2$ ,  $\gamma_m \varepsilon_{vhm}$  and  $\gamma_m \ell_{vh}$  in the imaginary part of the solution. Since the factor  $\varepsilon_{vhm}$  introduces a surface integral of the square of the eigenfunction  $\Phi_m^2$ , it is approximated by the surface to volume ratio  $S/V$  of the cavity and is therefore predominant against the dissipation of volume ( $\ell_{vh}$  factor) in small cavities.

There are many other forms of Green's functions suitable for specific problems of acoustics, but it is not the objective of this chapter to be exhaustive on this point.

### 6.1.5. Reciprocity of the Green's function

Equation (6.5) can also be written as

$$\Delta G(\vec{r}, t; \vec{r}_0, t_0) - \frac{1}{c^2} \frac{\partial^2 G(\vec{r}, t; \vec{r}_0, t_0)}{\partial t^2} = -\delta(\vec{r} - \vec{r}_0) \delta(t - t_0), \quad (6.48)$$

$$\text{and } \Delta G(\vec{r}, -t; \vec{r}_1, -t_1) - \frac{1}{c^2} \frac{\partial^2 G(\vec{r}, -t; \vec{r}_1, -t_1)}{\partial t^2} = -\delta(\vec{r} - \vec{r}_1) \delta(t - t_1). \quad (6.49)$$

The multiplication of equation (6.48) by  $G(\vec{r}, -t; \vec{r}_1, -t_1)$  and equation (6.49) by  $G(\vec{r}, t; \vec{r}_0, t_0)$  and the integration of the difference between the two results over the considered space and time leads to

$$\begin{aligned} & \int_{-\infty}^{\infty} dt \iiint_{(D)} d\vec{r}_0 \left[ G(\vec{r}, t; \vec{r}_0, t_0) \Delta G(\vec{r}, -t; \vec{r}_1, -t_1) - G(\vec{r}, -t; \vec{r}_1, -t_1) \Delta G(\vec{r}, t; \vec{r}_0, t_0) \right. \\ & \left. - \frac{1}{c^2} G(\vec{r}, t; \vec{r}_0, t_0) \frac{\partial^2}{\partial t^2} G(\vec{r}, -t; \vec{r}_1, -t_1) + \frac{1}{c^2} G(\vec{r}, -t; \vec{r}_1, -t_1) \frac{\partial^2}{\partial t^2} G(\vec{r}, t; \vec{r}_0, t_0) \right] \\ & = G(\vec{r}_0, -t_0; \vec{r}_1, -t_1) - G(\vec{r}_1, t_1; \vec{r}_0, t_0). \end{aligned} \quad (6.50)$$

The principle of causality implies that the left-hand side vanishes if  $t$  does not satisfy the condition  $t_0 < t < t_1$ . However, it also vanishes if this condition is satisfied. This can be demonstrated using Green's theorem and writing down the following identity:

$$\begin{aligned} & \frac{\partial}{\partial t} \left[ G(\vec{r}, t; \vec{r}_0, t_0) \frac{\partial}{\partial t} G(\vec{r}, -t; \vec{r}_1, -t_1) - G(\vec{r}, -t; \vec{r}_1, -t_1) \frac{\partial}{\partial t} G(\vec{r}, t; \vec{r}_0, t_0) \right] \\ & = G(\vec{r}, t; \vec{r}_0, t_0) \frac{\partial^2}{\partial t^2} G(\vec{r}, -t; \vec{r}_1, -t_1) - G(\vec{r}, -t; \vec{r}_1, -t_1) \frac{\partial^2}{\partial t^2} G(\vec{r}, t; \vec{r}_0, t_0), \end{aligned}$$

leading, for the left-hand side of equation (6.50), to

$$\begin{aligned} & \int_{-\infty}^{\infty} dt \iint_{(S)} d\vec{S} \left[ G(\vec{r}, t; \vec{r}_0, t_0) \text{grad} G(\vec{r}, -t; \vec{r}_1, -t_1) - G(\vec{r}, -t; \vec{r}_1, -t_1) \text{grad} G(\vec{r}, t; \vec{r}_0, t_0) \right] \\ & - \frac{1}{c^2} \iint_{(D)} d\vec{r} \left[ G(\vec{r}, t; \vec{r}_0, t_0) \frac{\partial G(\vec{r}, -t; \vec{r}_1, -t_1)}{\partial t} - G(\vec{r}, -t; \vec{r}_1, -t_1) \frac{\partial G(\vec{r}, t; \vec{r}_0, t_0)}{\partial t} \right]_{t=-\infty}^{t=\infty}. \end{aligned}$$

The first term of equation (6.50) vanishes as both forms of Green's function satisfy the same boundary conditions and the second term vanishes by virtue of the principle of causality. Consequently, equation (6.50) becomes

$$G(\vec{r}_0, -t_0; \vec{r}, -t) = G(\vec{r}, t; \vec{r}_0, t_0). \quad (6.51)$$

This constitutes the reciprocity property of the Green's function. It can be interpreted as follows: the effect at the point  $\vec{r}$  and time  $t$  of a pulse emitted at  $\vec{r}_0$  at an earlier time  $t_0$  ( $t > t_0$ ) is equal to the effects at the point  $\vec{r}_0$  and time  $(-t_0)$  of a pulse emitted at  $\vec{r}$  at the time  $(-t)$  with  $(-t_0 > -t)$ .



## 6.2. Integral formalism of boundary problems in linear acoustics

### 6.2.1. Introduction

#### 6.2.1.1. In general

As indicated at the beginning of section 6.1.3, one can use Green's functions (elementary solutions) to obtain, by superposition of elementary fields, the solution to boundary problems written as integral equations (equations (6.1) and (6.2)). This integral formalism does not assume, *a priori*, any boundary conditions on the Green's functions, so that they only need to satisfy the following equation of propagation:

$$\left[ \Delta - \frac{1}{c^2} \frac{\partial^2}{\partial t^2} \right] G(\vec{r}, t; \vec{r}_0, t_0) = -\delta(\vec{r} - \vec{r}_0) \delta(t - t_0) \quad (6.52)$$

in the domain (D) considered. The boundary conditions satisfied by these elementary solutions result from an *a posteriori* choice depending on the problem considered and on the method used to obtain the solution.

This integral formalism offers a more comprehensive interpretation of the phenomena at hand, and a wider range of problems can be analytically solved by this method. It is, however, the increasing power and speed of computers which have generalized its use.

These integral representations, leading to an integral equation or a system of integral equations, are equivalent to the differential equations. The conditions of uniqueness and existence of the solutions are the same in both cases.

Once again, the objective of this section is to present a "tool" directly available to any physicist. Consequently, many of these "demonstrations" are not mathematically rigorous. All the notions used hereinafter are to be taken in the context of the theory of distributions even though everything is presented so that one does not need to be familiar with the theory to understand the following developments.

#### 6.2.1.2. Green's theorem

Let  $\Phi$  and  $\Psi$  be two functions defined in an opened domain (D) delimited by a close surface (S) and which first derivatives are also defined in the same domain. Then

$$\text{grad} \Phi \text{ grad} \Psi = \text{div} (\Phi \text{ grad} \Psi) - \Phi \Delta \Psi = \text{div} (\Psi \text{ grad} \Phi) - \Psi \Delta \Phi \quad (6.53)$$

leads to

$$\iiint_{(D)} \text{grad } \Phi \text{ grad } \psi \, dD = \iint_{(S)} \psi \bar{n} \cdot \bar{\nabla} \Phi \, dS - \iiint_{(D)} \psi \Delta \Phi \, dD, \quad (6.54a)$$

$$\text{and } \iiint_{(D)} \text{grad } \Phi \text{ grad } \psi \, dD = \iint_{(S)} \Phi \bar{n} \cdot \bar{\nabla} \psi \, dS - \iiint_{(D)} \Phi \Delta \psi \, dD. \quad (6.54b)$$

Consequently, subtracting (6.54a) from (6.54b) gives

$$\iiint_{(D)} (\psi \Delta \Phi - \Phi \Delta \psi) \, dD = \iint_{(S)} (\psi \bar{n} \cdot \bar{\nabla} \Phi - \Phi \bar{n} \cdot \bar{\nabla} \psi) \, dS, \quad (6.55)$$

where  $\bar{n}$  is a unit vector, normal to (S) outgoing from (D).

Equation (6.55) is the expression of Green's theorem in a three-dimensional domain. In a two-dimensional domain, it is

$$\iint_{(S)} (\psi \Delta \Phi - \Phi \Delta \psi) \, dS = \oint_C (\psi \bar{n} \cdot \bar{\nabla} \Phi - \Phi \bar{n} \cdot \bar{\nabla} \psi) \, d\ell, \quad (6.56)$$

where (S) is the opened 2D domain delimited by the close curve (C),  $\bar{n}$  being the unit vector normal to (C). And in a 1D domain restricted to an interval  $[a, b]$ , Green's theorem is written as

$$\int_a^b \left( \psi \frac{d^2}{dx^2} \Phi - \Phi \frac{d^2}{dx^2} \psi \right) dx = \left[ \psi \frac{d\Phi}{dx} - \Phi \frac{d\psi}{dx} \right]_a^b \quad (6.57)$$

## 6.2.2. Integral formalism

### 6.2.2.1. Time domain

In a three-dimensional domain, let the function  $\Phi$  denote the Green's function  $G(\bar{r}, t; \bar{r}_0, t_0)$ , which satisfies the equation of propagation (6.52), and  $\Psi$  the solution  $p(\bar{r}, t)$  of the problem (6.1). By integrating the resulting Green's theorem over the period  $[t_0, t^+]$  ( $t_0$  being the initial time  $t_i$ , and  $t^+$  the current time by greater value), and since the Green's function vanishes for  $t_0 > t$ , one obtains

$$\int_{t_i}^{t^+} dt_0 \iiint_{(D)} dD_0 [p(\bar{r}_0, t_0) \Delta_0 G(\bar{r}, t; \bar{r}_0, t_0) - G(\bar{r}, t; \bar{r}_0, t_0) \Delta_0 p(\bar{r}_0, t_0)] =$$

$$\int_{t_i}^{t^+} dt_0 \iiint_{(S_0)} d\bar{S}_0 [p(\bar{r}_0, t_0) \text{grad}_0 G(\bar{r}, t; \bar{r}_0, t_0) - G(\bar{r}, t; \bar{r}_0, t_0) \text{grad}_0 p(\bar{r}_0, t_0)], \quad (6.58)$$

or, considering the equations of propagation (6.52) and (6.1a),

$$\begin{aligned}
 & \int_{t_i}^{t^+} dt_0 \iiint_{(D)} dD_0 \left( p(\bar{r}_0, t_0) \left[ \frac{1}{c^2} \frac{\partial^2}{\partial t_0^2} G(\bar{r}, t; \bar{r}_0, t_0) - \delta(\bar{r} - \bar{r}_0) \delta(t - t_0) \right] \right. \\
 & \left. - G(\bar{r}, t; \bar{r}_0, t_0) \left[ \frac{1}{c^2} \frac{\partial^2}{\partial t_0^2} p(\bar{r}_0, t_0) - f(\bar{r}_0, t_0) \right] \right) \\
 & = \int_{t_i}^{t^+} dt_0 \left[ p(\bar{r}_0, t_0) \frac{\partial}{\partial n_0} G(\bar{r}, t; \bar{r}_0, t_0) - G(\bar{r}, t; \bar{r}_0, t_0) \frac{\partial}{\partial n_0} p(\bar{r}_0, t_0) \right], \quad (6.59)
 \end{aligned}$$

where  $\partial / \partial n_0$  denotes the derivative with respect to the outgoing normal to the surface

$$\left( \frac{\partial}{\partial n_0} = \frac{d\bar{S}_0}{dS_0} \cdot \text{grad}_0 = \bar{n}_0 \cdot \text{grad}_0 \right).$$

However, since

$$p \frac{\partial^2}{\partial t_0^2} G - G \frac{\partial^2}{\partial t_0^2} p = \frac{\partial}{\partial t_0} \left[ p \frac{\partial}{\partial t_0} G - G \frac{\partial}{\partial t_0} p \right],$$

equation (6.59) finally becomes

$$\begin{aligned}
 & \left. \begin{array}{l} r \in (D), \quad p(\bar{r}, t) \\ r \notin (D), \quad 0 \end{array} \right\} \\
 & = \int_{t_i}^{t^+} dt_0 \iiint_{(D)} dD_0 G(\bar{r}, t; \bar{r}_0, t_0) f(\bar{r}_0, t_0) \\
 & + \int_{t_i}^{t^+} dt_0 \iint_{(S)} dS_0 \left[ G(\bar{r}, t; \bar{r}_0, t_0) \frac{\partial}{\partial n_0} p(\bar{r}_0, t_0) - p(\bar{r}_0, t_0) \frac{\partial}{\partial n_0} G(\bar{r}, t; \bar{r}_0, t_0) \right] \\
 & + \frac{1}{c^2} \iiint_{(D)} dD_0 \left[ G(\bar{r}, t; \bar{r}_0, t_0) \frac{\partial}{\partial t_0} p(\bar{r}_0, t_0) - p(\bar{r}_0, t_0) \frac{\partial}{\partial t_0} G(\bar{r}, t; \bar{r}_0, t_0) \right]_{t_0=t_i}. \quad (6.60)
 \end{aligned}$$

The first integral denotes the contribution of the real sources distributed in the domain (D) to the acoustic pressure field, and eventually the contribution of image

sources, depending on the choice of Green's function. The second integral (over the boundary of the domain) denotes the contribution of the wall reflections if they are not already taken into consideration in the Green's function. The third and last integral introduces the initial conditions  $p(\vec{r}_0, t_i)$  and  $\partial p(\vec{r}_0, t_i) / \partial t_i$ .

These integrals are actually convolutions since the Green's function depends on the variables  $(\vec{r} - \vec{r}_0)$  and  $(t - t_0)$ . Convolution integrals over the period of time highlight the fact that the contribution of the sources to the acoustic field in the domain (D) includes radiation from the sources since the time  $t_0 \geq t_i$ .

Equation (6.60) is an integral equation since its solution  $p$ , for any point  $\vec{r} \in D$ , depends on the values taken by the different terms of the equations and that its first normal derivative is defined at the boundary (S) of the domain.

Note 1: the domain (D) can denote an open domain ( $D^-$ ) delimited by a closed surface (S) or an open domain ( $D^+$ ) exterior to the surface surface. The same domain (D) can also denote any domain ( $D^+ \cup D^-$ ) excluding the surface (S) apart from the sources that remain included in (D).

Note 2: in the case of a two- or one-dimensional domain, one needs to replace the volume integrals in equation (6.60) with double or single integrals, respectively, and substitute the integrals

$$\iint dS_0 \left( G \frac{\partial}{\partial n_0} p - p \frac{\partial}{\partial n_0} G \right)$$

by respectively

$$\oint_C d\ell_0 \left( G \frac{\partial p}{\partial n_0} - p \frac{\partial G}{\partial n_0} \right), \tag{6.61}$$

$$\text{or } \left[ G \frac{\partial p}{\partial n_0} - p \frac{\partial G}{\partial n_0} \right]_a^b. \tag{6.62}$$

### 6.2.2.2. Frequency domain

Under null initial conditions (a situation one can often reduce the problem to), the integral equation in the frequency domain can be obtained by simple Fourier transform of equation (6.60) since the time integrals are actually convolution integrals. It can also be obtained from equations (6.55) or (6.56), and (6.57) integrating over the domain (D) and by writing that the functions  $p$  and  $G$  satisfy,

respectively, the Helmholtz equations associated with (6.1) and (6.55). The integral equation in the frequency domain is then

$$\left. \begin{array}{l} r \in (D), \\ r \notin (D), \end{array} \right\} \begin{array}{l} p(\vec{r}) \\ 0 \end{array} = \iiint_{(D)} dD_0 G(\vec{r}, \vec{r}_0) f(\vec{r}_0) + \iint_{(S)} dS_0 \left[ G(\vec{r}, \vec{r}_0) \frac{\partial}{\partial n_0} p(\vec{r}_0) - p(\vec{r}_0) \frac{\partial}{\partial n_0} G(\vec{r}, \vec{r}_0) \right], \quad (6.63)$$

where the functions  $p$ ,  $f$  and  $G$  are the Fourier transforms of previously defined functions. The comments made in the previous section hold in the frequency domain.

The suggested interpretation of equation (6.60) can, apart from the time-related remarks, be applied to equation (6.63). The contribution of the boundary reaction to the acoustic field results from the radiation from a monopolar layer (factor  $G(\vec{r}, \vec{r}_0)$ ) of “intensity” proportional to the particle velocity at the wall (factor  $\partial p / \partial n_0$ ) and from a dipolar layer of “intensity” proportional to the structure-borne pressure. This reaction depends on the vibratory characteristics of the boundary, but also on the pressure and particle velocity field that contributes to the vibration motion of the wall. Generally, the vibrations of the wall can be described by non-homogeneous mixed boundary conditions such as (1.70), including the material reaction described by the specific admittance  $\beta$  and the forced dynamic response of the wall surface described by the vibration velocity  $V_0 = U_0 / i\omega\rho_0$ .

### 6.2.3. On solving integral equations

#### 6.2.3.1. General method

For the sake of simplicity, only the integral equation (6.63) in the frequency domain will be analyzed in this section. However, a similar analysis could be made in the time domain.

The Green’s function  $G(\vec{r}, \vec{r}_0)$  being known, equation (6.63) leads to the solution in the three-dimensional domain (D) as long as it is defined and known over the delimiting surface (S). In many simple cases, the given physical conditions of the considered problem are a source of information on the solution at the boundaries and, if the Green’s function is appropriately chosen, lead directly to the solution of the problem in the entire domain by calculating the integrals in the second term of equation (6.63).

In the case of more complex problems, the solution at the boundary must be calculated. The mathematical projection of the point  $\vec{r}$  from the domain (D) onto a point  $\vec{r}_S$  on the boundary (S) leads, for an unknown  $p(\vec{r}_S)$ ,  $\vec{r}_S \in (S)$ , to the following integral equation:

$$\begin{aligned} \frac{p(\vec{r}_S)}{2} = & \iiint_{(D)} f(\vec{r}_0) G(\vec{r}_S, \vec{r}_0) dD_0 \\ & + \iint_{(S)} \left[ G(\vec{r}_S, \vec{r}_0) \frac{\partial}{\partial n_0} p(\vec{r}_0) - p(\vec{r}_0) \frac{\partial}{\partial n_0} G(\vec{r}_S, \vec{r}_0) \right]. \end{aligned} \quad (6.64)$$

If, for example, the normal derivative  $\partial p / \partial n_0$  is known at the boundary, this equation is a singular Fredholm's integral equation of the 2<sup>nd</sup> kind (which integrand can be integrated despite the singularities). Obtaining the solutions then requires mathematical or numerical methods that are not considered in this book. More generally, since this book does not treat the mathematical and numerical methods for solving integral equations, this section will only focus on the problems where the integral equations can be transformed into integral "solutions" or, in other words, into the problems for which solutions can be derived directly from the known solution at the boundaries of the considered domain. Nevertheless, a demonstration of equation (6.64) will be presented, followed by an introduction to the derivation of the solutions for two particular boundary problems: the non-homogeneous exterior Neumann's problem and the non-homogeneous interior Dirichlet's problem.

### 6.2.3.2. Limits of the integral equations at the frontier

According to the first comment in section 6.2.2.1, the domain (D) can indifferently represent an interior opened domain ( $D^-$ ), an exterior open domain ( $D^+$ ) or the union of both ( $D^- \cup D^+$ ) that represents the entire space, but the surface (S). In the last case, since the Green's function and its first derivative do not present any singularity over (S), equation (6.63) becomes, for  $\vec{r} \in (D^- \cup D^+)$ ,

$$\begin{aligned} p(\vec{r}) = & \iiint_{(D^- \cup D^+)} G(\vec{r}, \vec{r}_0) f(\vec{r}_0) dD_0 \\ & + \iint_{(S)} \left[ \mu_d(\vec{r}_0) \frac{\partial G(\vec{r}, \vec{r}_0)}{\partial n_0} - \mu_s(\vec{r}_0) G(\vec{r}, \vec{r}_0) \right] dS_0, \end{aligned} \quad (6.65)$$

$$\text{with } \mu_s(\vec{r}_0) = \left( \frac{\partial p}{\partial n_0} \right)_+ - \left( \frac{\partial p}{\partial n_0} \right)_-, \quad (6.66a)$$

$$\text{and } \mu_d(\vec{r}_0) = p_+ - p_-, \quad (6.66b)$$

$\mu_s$  and  $\mu_d$  denote, respectively, the potential densities of single and double layers, representing the discontinuities at (S) of the normal derivative of the pressure ( $\mu_s$ ) and of the pressure itself ( $\mu_d$ ).

As shown in the previous sections, finding solutions to these problems generally requires the limit of this equation when  $\vec{r}$  tends to an arbitrary point  $\vec{r}_S$  of the surface (S). Indeed, the solution  $p(\vec{r}_S)$  (and/or its first derivative  $\partial p(\vec{r}_S)/\partial n$ ) substituted into equation (6.65) leads to the solution  $p(\vec{r})$  for any given  $\vec{r}$  inside ( $D^+$ ) or ( $D^-$ ). However, precaution must be taken when calculating the limits of  $p(\vec{r}_S)$  and  $\partial p(\vec{r}_S)/\partial n$  at the boundary because of the discontinuities of the single and double potential densities. When considering equation (6.65), the solution is given by

$$p = p_f + p_s + p_d.$$

The expressions of  $p_f$ ,  $p_s$  and  $p_d$  are given by the three terms in the right-hand side of equation (6.65):

$$p_f(\vec{r}) = \iiint_{(D^+ \cup D^-)} G(\vec{r}, \vec{r}_0) f(\vec{r}_0) d\vec{r}_0, \quad (6.67a)$$

$$p_s(\vec{r}) = -\iint_{(S)} \mu_s(\vec{r}_0) G(\vec{r}, \vec{r}_0) d\vec{r}_0, \quad (6.67b)$$

$$p_d(\vec{r}) = \iint_{(S)} \mu_d(\vec{r}_0) \frac{\partial G(\vec{r}, \vec{r}_0)}{\partial n_0} d\vec{r}_0. \quad (6.67c)$$

The factor  $p_f$  denotes the acoustic field generated by the active sources within ( $D^+ \cup D^-$ ) and is called the direct field. The factors  $p_s$  and  $p_d$  introduce the effect of the discontinuities of the field and its derivative on the acoustic field  $p(\vec{r})$ . The Green's function  $G(\vec{r}, \vec{r}_0)$  introduced in the surface integrals must satisfy Sommerfeld's condition at infinity (to guarantee that no reflected wave is traveling in the opposite direction) and takes the spherical wave form  $\exp(-ik|\vec{r} - \vec{r}_0|)/(4\pi|\vec{r} - \vec{r}_0|)$  in a three-dimensional domain.

When  $\vec{r}$  tends to  $\vec{r}_S \in (S)$ , the limit of the integral

$$p_f(\vec{r}_S) = \lim_{\vec{r} \rightarrow \vec{r}_S} \iiint_{(D^+ \cup D^-)} G(\vec{r}, \vec{r}_0) f(\vec{r}_0) d\vec{r}_0 \quad (6.68)$$

is given by

$$p_f(\vec{r}_S) = \iiint_{(D^+ \cup D^-)} G(\vec{r}_S, \vec{r}_0) f(\vec{r}_0) d\vec{r}_0. \quad (6.69)$$

For the potentials  $p_s$  and  $p_d$  things are unfortunately not that simple. In the case of the single layer potential  $p_s$ , the normal derivative presents, by hypothesis, a discontinuity  $\mu_s$  at (S):

$$\left[ \frac{\partial}{\partial n} p_s(\vec{r}_S) \right]_+ - \left[ \frac{\partial}{\partial n} p_s(\vec{r}_S) \right]_- = \mu_s(\vec{r}_S), \quad (6.70)$$

even though  $p_s$  itself does not. The pressure field is indeed continuous in space:

$$[p_s(\vec{r}_S)]_+ - [p_s(\vec{r}_S)]_- = 0. \quad (6.71)$$

Consequently, if the limit for  $\vec{r} \rightarrow \vec{r}_S$  of the potential  $p_s$  is given by

$$p_s(\vec{r}_S) = - \iint_{(S)} \mu_s(\vec{r}_0) G(\vec{r}_S, \vec{r}_0) d\vec{r}_0, \quad (6.72)$$

the expression of the limit of its normal derivative, given by

$$\frac{\partial}{\partial n} p_s(\vec{r}) = - \iint_{(S)} \mu_s(\vec{r}_0) \frac{\partial}{\partial n} G(\vec{r}, \vec{r}_0) d\vec{r}_0, \quad (6.73)$$

is only valid in  $(D^+ \cup D^-)$ , but not in (S), when  $\vec{r} = \vec{r}_S$ . For  $\vec{r} \rightarrow \vec{r}_S$  the sum

$$\begin{aligned} & \left[ \frac{\partial}{\partial n_s} p_s(\vec{r}_S) \right]_+ + \left[ \frac{\partial}{\partial n_s} p_s(\vec{r}_S) \right]_- \\ &= - \lim_{\vec{r}_\pm \rightarrow \vec{r}_S} \iint_{(S)} \mu_s(\vec{r}_0) \frac{\partial}{\partial n} [G(\vec{r}_+, \vec{r}_0) + G(\vec{r}_-, \vec{r}_0)] d\vec{r}_0, \end{aligned} \quad (6.74)$$

where the operator  $\partial/\partial n$  is applied to  $\vec{r}_+$  and  $\vec{r}_-$ , and where  $\vec{r}_+$  and  $\vec{r}_-$  are symmetrical with one another with respect to  $\vec{r}_S$ , is continuous through (S) and, according to the condition of continuity of the derivative of a Green's function, given by

$$\left[ \frac{\partial}{\partial n_s} p_s(\vec{r}_S) \right]_+ + \left[ \frac{\partial}{\partial n_s} p_s(\vec{r}_S) \right]_- = -2 \iint_{(S)} \mu_s(\vec{r}_0) \frac{\partial}{\partial n_s} G(\vec{r}_S, \vec{r}_0) d\vec{r}_0, \quad (6.75)$$

where the operator  $\partial/\partial n$  is applied to  $\vec{r}_S$ .



The sum and difference of equations (6.75) and (6.70) lead, respectively, to the following results:

$$\left[ \frac{\partial}{\partial n_s} p_s(\bar{r}_S) \right]_+ = \frac{\mu_s(\bar{r}_S)}{2} - \iint_{(S)} \mu_s(\bar{r}_0) \frac{\partial}{\partial n_s} G(\bar{r}_S, \bar{r}_0) d\bar{r}_0, \quad (6.76)$$

$$\left[ \frac{\partial}{\partial n_s} p_s(\bar{r}_S) \right]_- = -\frac{\mu_s(\bar{r}_S)}{2} - \iint_{(S)} \mu_s(\bar{r}_0) \frac{\partial}{\partial n_s} G(\bar{r}_S, \bar{r}_0) d\bar{r}_0. \quad (6.77)$$

Finally, when only the single layer potential is superposed to the direct field  $p_f$ ,

$$p = p_f + p_s, \quad (6.78)$$

equation (6.72)

$$p_s(\bar{r}_S) = -\iint_{(S)} \mu_s(\bar{r}_0) G(\bar{r}_S, \bar{r}_0) d\bar{r}_0, \quad (6.79)$$

and equation (6.76) when the problem is internal (or 6.77 when the problem is external) lead to the unknown  $\mu_s(\bar{r}_S)$  for a Dirichlet's problem where  $p_s(\bar{r}_S) = p(\bar{r}_S) - p_f(\bar{r}_S)$  is known or, if the problem is external to a Neumann's problem where  $\partial p_s(\bar{r}_S) / \partial n_s = \partial p(\bar{r}_S) / \partial n_s - \partial p_f(\bar{r}_S) / \partial n_s$  is known.

The solution is then

$$p(\bar{r}) = \iiint_{(D^+ \cup D^-)} G(\bar{r}, \bar{r}_0) f(\bar{r}_0) d\bar{r}_0 - \iint_{(S)} \mu_s(\bar{r}_0) G(\bar{r}, \bar{r}_0) d\bar{r}_0. \quad (6.80)$$

Considering now the double layer potential  $p_d$ , the method adopted below is in perfect analogy with the previous one for  $p_s$ . By hypothesis, the double layer potential presents a discontinuity  $\mu_d$  at the surface (S) defined by

$$[p_d(\bar{r}_S)]_+ - [p_d(\bar{r}_S)]_- = \mu_d(\bar{r}_S), \quad (6.81)$$

but its normal derivative is continuous through the surface (S) (because continuous in the entire domain):

$$\left[ \frac{\partial}{\partial n_s} p_d(\bar{r}_S) \right]_+ - \left[ \frac{\partial}{\partial n_s} p_d(\bar{r}_S) \right]_- = 0. \quad (6.82)$$

Consequently, if the limit for  $\bar{r} \rightarrow \bar{r}_S$  of the derivative of the potential is given by

$$\frac{\partial}{\partial n_s} p_d(\bar{r}_S) = \iint_{(S)} \mu_d(\bar{r}_0) \frac{\partial}{\partial n_s} \frac{\partial}{\partial n_0} G(\bar{r}_S, \bar{r}_0) d\bar{r}_0, \quad (6.83)$$

the expression of the limit of the potential itself, given by

$$p_d(\vec{r}) = \iint_{(S)} \mu_d(\vec{r}_0) \frac{\partial}{\partial n_0} G(\vec{r}, \vec{r}_0) d\vec{r}_0, \quad (6.84)$$

is only valid in  $(D^+ \cup D^-)$ , but not in  $(S)$ , when  $\vec{r} = \vec{r}_S$ . For  $\vec{r} \rightarrow \vec{r}_S$  the sum

$$[p_d(\vec{r}_S)]_+ + [p_d(\vec{r}_S)]_- = \lim_{\vec{r} \rightarrow \vec{r}_S} \iint_{(S)} \mu_d(\vec{r}_0) \frac{\partial}{\partial n_0} [G(\vec{r}_+, \vec{r}_0) + G(\vec{r}_-, \vec{r}_0)] d\vec{r}_0, \quad (6.85)$$

where  $\vec{r}_+$  and  $\vec{r}_-$  are symmetrical with one another with respect to  $\vec{r}_S$ , is continuous through  $(S)$  and, according to the condition of continuity of the derivative of a Green's function, given by

$$[p_d(\vec{r}_S)]_+ - [p_d(\vec{r}_S)]_- = 2 \iint_{(S)} \mu_d(\vec{r}_0) \frac{\partial}{\partial n_0} G(\vec{r}_S, \vec{r}_0) d\vec{r}_0. \quad (6.86)$$

The sum and the difference of equations (6.86) and (6.81) lead, respectively, to the following results:

$$[p_d(\vec{r}_S)]_+ + [p_d(\vec{r}_S)]_- = 2 \iint_{(S)} \mu_d(\vec{r}_0) \frac{\partial}{\partial n_0} G(\vec{r}_S, \vec{r}_0) d\vec{r}_0. \quad (6.87)$$

$$[p_d(\vec{r}_S)]_- = -\frac{\mu_d(\vec{r}_S)}{2} + \iint_{(S)} \mu_d(\vec{r}_0) \frac{\partial}{\partial n_0} G(\vec{r}_S, \vec{r}_0) d\vec{r}_0. \quad (6.88)$$

Finally, when only the double layer potential is superposed to the direct field  $p_f$ ,

$$p = p_f + p_d, \quad (6.89)$$

equation (6.83)

$$\frac{\partial}{\partial n_s} p_d(\vec{r}_S) = \iint_{(S)} \mu_d(\vec{r}_0) \frac{\partial}{\partial n_s} \frac{\partial}{\partial n_0} G(\vec{r}_S, \vec{r}_0) d\vec{r}_0, \quad (6.90)$$

and equation (6.87) leads to an unknown  $\mu_d(\vec{r}_S)$  for a Dirichlet's problem (where  $p_d(\vec{r}_S) = p(\vec{r}_S) - p_f(\vec{r}_S)$  is known), while equation (6.88) leads to a Neumann's problem (where  $\partial p_d(\vec{r}_S) / \partial n_s = \partial p(\vec{r}_S) / \partial n_s - \partial p_f(\vec{r}_S) / \partial n_s$  is known).

The solution is then

$$p(\vec{r}) = \iiint_{(D^+ \cup D^-)} G(\vec{r}, \vec{r}_0) f(\vec{r}_0) d\vec{r}_0 + \iint_{(S)} \mu_d(\vec{r}_0) \frac{\partial}{\partial n_0} G(\vec{r}, \vec{r}_0) d\vec{r}_0. \quad (6.91)$$

6.2.3.3. Example of solution: non-homogeneous exterior Neumann's problem

The differential formalism of such problem is

$$\left\{ \begin{array}{l} (\Delta + k^2) p(\bar{r}) = -f(\bar{r}), \quad \bar{r} \in D^+, \\ \frac{\partial p(\bar{r}_S)}{\partial n} = v(\bar{r}_S), \quad \bar{r}_S \in S, \\ \text{Sommerfeld's condition at infinity.} \end{array} \right. \quad (6.92)$$

The integral formalism can, if the normal derivative is there defined inward of the domain ( $D^+$ ), be written as

$$\begin{aligned} & \iiint_{(D^+)} G(\bar{r}, \bar{r}_0) f(\bar{r}_0) d\bar{r}_0 \\ & - \iint_{(S)} \left[ G(\bar{r}, \bar{r}_0) \frac{\partial}{\partial n_0} p(\bar{r}_0) - p(\bar{r}_0) \frac{\partial}{\partial n_0} G(\bar{r}, \bar{r}_0) \right] d\bar{r}_0 = \begin{cases} p(\bar{r}), & \bar{r} \in D^+, \\ 0, & \bar{r} \in D^-. \end{cases} \end{aligned} \quad (6.93)$$

The factor  $\partial p(\bar{r}_0) / \partial n_0 = v(\bar{r}_0)$  is, by hypothesis, known (boundary condition) and the function  $p(\bar{r}_0)$ , denoted indifferently  $p(\bar{r}_S)$ , is given by the respective substitutions of equations (6.69), (6.72) and (6.87) into the three terms of equation (6.93) for  $\bar{r} \rightarrow \bar{r}_S$ . By noting that  $\mu_s(\bar{r}_S) = \partial p(\bar{r}_S) / \partial n_s$  and  $\mu_d(\bar{r}_S) = p(\bar{r}_S)$  (since the field is extended with zeros in  $D^-$ ), the solution is

$$\begin{aligned} & p(\bar{r}_S) \\ & = \lim_{\bar{r} \rightarrow \bar{r}_S} \left( \iiint_{(D^+)} G(\bar{r}, \bar{r}_0) f(\bar{r}_0) d\bar{r}_0 - \iint_{(S)} \left[ G(\bar{r}, \bar{r}_0) \frac{\partial}{\partial n_0} p(\bar{r}_0) - p(\bar{r}_0) \frac{\partial}{\partial n_0} G(\bar{r}, \bar{r}_0) \right] d\bar{r}_0 \right) \\ & = \iiint_{(D^+)} G(\bar{r}_S, \bar{r}_0) f(\bar{r}_0) d\bar{r}_0 - \iint_{(S)} G(\bar{r}_S, \bar{r}_0) \frac{\partial}{\partial n_0} p(\bar{r}_0) d\bar{r}_0 + \frac{p(\bar{r}_S)}{2} \\ & \quad + \iint_{(S)} p(\bar{r}_0) \frac{\partial}{\partial n_0} G(\bar{r}_S, \bar{r}_0) d\bar{r}_0, \end{aligned}$$

and finally

$$\begin{aligned} \frac{p(\bar{r}_S)}{2} & = \iiint_{(D^+)} G(\bar{r}_S, \bar{r}_0) f(\bar{r}_0) d\bar{r}_0 - \iint_{(S)} G(\bar{r}_S, \bar{r}_0) \frac{\partial}{\partial n_0} p(\bar{r}_0) d\bar{r}_0 \\ & \quad - \iint_{(S)} p(\bar{r}_0) \frac{\partial}{\partial n_0} G(\bar{r}_S, \bar{r}_0) d\bar{r}_0. \end{aligned} \quad (6.94)$$

The substitution of the solution  $p(\vec{r}_S)$  of equation (6.94) into equation (6.93) leads to the solution to problem (6.92).

6.2.3.4. *Example of solution: non-homogeneous interior Dirichlet's problem*

To find the solution to the Dirichlet's problem in which the boundary condition  $p(\vec{r}_S) = W(\vec{r}_S)$ , one requires the solution to the following integral equation at the boundary rather than the solution to equation (6.94):

$$\begin{aligned} \frac{\partial}{\partial n_s} p(\vec{r}_S) / 2 = & \iiint_{(D^+)} G(\vec{r}_S, \vec{r}_0) f(\vec{r}_0) d\vec{r}_0 \\ & - \iint_{(S)} \left[ \frac{\partial}{\partial n_S} G(\vec{r}_S, \vec{r}_0) \frac{\partial}{\partial n_0} p(\vec{r}_0) - p(\vec{r}_0) \frac{\partial}{\partial n_s} \frac{\partial}{\partial n_0} G(\vec{r}_S, \vec{r}_0) \right] d\vec{r}_0. \end{aligned} \tag{6.95}$$

Note 1: the surface integrals, the integrands of which contain the Green's function  $G(\vec{r}_S, \vec{r}_0)$ , or its normal derivative, unbounded function at  $\vec{r}_0 = \vec{r}_S$ , are to be taken as Cauchy's principle value (P.V.), defined as

$$P.V. \int_a^b f(x) dx = \lim_{\epsilon \rightarrow 0} \left( \int_a^{c-\epsilon} + \int_{c+\epsilon}^b \right) f(x) dx. \tag{6.96}$$

The principal value of the surface integrals, the integrands of which contain the second derivative of the Green's function, is not defined. However, these integrals exist and are called finite parts (FP).

Note 2: the derivation of the solution to an exterior problem using the single layer potential leads to the integral equations whose real eigenvalues are those of the interior Dirichlet's. If one uses the double layer potential, then one will obtain the integral equations with which the real eigenvalues of the Neumann's problem are associated. To these eigenvalues correspond an infinity of solutions, and outside the set of eigenvalues, the solution is unique.

Note 3: the integral equation (6.80), for example, can also be written, by definition of the Dirac  $\delta_{S_0}$ , as

$$p(\vec{r}) = \iiint_{(D)} G(\vec{r}, \vec{r}_0) [f(\vec{r}_0) - \delta_{S_0} \mu_S(\vec{r}_0)] d\vec{r}_0, \tag{6.97}$$

or, since the integral represents a convolution product, as

$$p = G * (f - \mu_S \delta_S). \tag{6.98}$$

Presented as such, the problem is expressed as a non-homogeneous Helmholtz equation:

$$(\Delta + k^2)p = -(f - \mu_s \delta_S), \quad (6.99)$$

$$\text{or } \{\Delta p\} + k^2 p = -f, \quad (6.100)$$

where

$$\{\Delta p\} = \Delta p - \left[ \left( \frac{\partial p}{\partial n} \right)_+ - \left( \frac{\partial p}{\partial n} \right)_- \right] \delta_S \quad (6.101)$$

denotes the Laplacian of the function  $p$  outside of the domain  $(S)$ .

Note 4: if the Green's function is chosen as  $e^{-ikr}/(4\pi r)$ , Sommerfeld's condition is implicitly considered by the limit of the integral of (6.60) over the surface of a sphere when  $R \rightarrow \infty$ :

$$\begin{aligned} \lim_{R \rightarrow \infty} \iint_{(4\pi)} \left[ \frac{e^{-ikR}}{4\pi R} \frac{\partial p}{\partial R} - p \frac{\partial}{\partial R} \left( \frac{e^{-ikR}}{4\pi R} \right) \right] R^2 d\Omega \\ = \lim_{R \rightarrow \infty} \iint_{(4\pi)} \frac{R}{4\pi} \left( \frac{\partial p}{\partial R} + ikp + \frac{p}{R} \right) e^{-ikR} d\Omega. \end{aligned}$$

The last integral is equal to zero if

$$\lim_{R \rightarrow \infty} R \left( \frac{\partial p}{\partial R} + ikp \right) = 0. \quad (6.102)$$

This is Sommerfeld's condition. In a two-dimensional space, it becomes

$$\lim_{R \rightarrow \infty} \sqrt{R} \left( \frac{\partial p}{\partial R} + ikp \right) = 0. \quad (6.103)$$

### 6.3. Examples of application

#### 6.3.1. Examples of application in the time domain

##### 6.3.1.1. Field generated in a three-dimensional infinite space

The problem can be written as:

$$\left\{ \begin{array}{l} \left[ \Delta - \frac{1}{c_0^2} \frac{\partial^2}{\partial t^2} \right] p(\vec{r}, t) = -f(\vec{r}, t), \quad \forall \vec{r} \in (D), \quad \forall t \in (t_i, \infty), \\ \text{Sommerfeld's condition at infinity,} \\ \text{null initial conditions.} \end{array} \right. \quad (6.104)$$

The equivalent integral equation is, according to equation (6.60)

$$\begin{aligned} p(\vec{r}, t) &= \frac{1}{4\pi} \int_{t_i}^{t^+} dt_0 \iiint dD_0 \frac{1}{|\vec{r} - \vec{r}_0|} \delta \left[ \frac{|\vec{r} - \vec{r}_0|}{c_0} - (t - t_0) \right] f(\vec{r}_0, t_0), \\ &= \iiint dD_0 \frac{1}{4\pi |\vec{r} - \vec{r}_0|} f \left[ \vec{r}_0, \frac{|\vec{r} - \vec{r}_0|}{c_0} - t \right]. \end{aligned} \quad (6.105)$$

This solution is called “delayed potential” and its interpretation is straightforward.

Specific example: the punctual source is moving at the constant velocity  $\vec{v}$  ( $v < c_0$ ). In accordance with equation (3.29), it is a source of volume velocity equal to  $q = Q_0 \delta(\vec{r}_0 - \vec{v}t_0)$ . The solution for the pressure field  $p = -\rho_0 \partial \phi / \partial t$  can then be written, according to equation (6.105), as

$$p = \frac{\rho_0 Q_0}{4\pi} \int_{t_i}^{t^+} dt_0 \frac{1}{|\vec{r} - \vec{v}t_0|} \delta \left[ \frac{|\vec{r} - \vec{v}t_0|}{c_0} - (t - t_0) \right]. \quad (6.106)$$

The change of variable  $u = (|\vec{r} - \vec{v}t_0|/c_0) + t_0$  leads directly to the following result (Figure 6.5):

$$p = \frac{\rho_0 Q_0}{4\pi} \frac{c_0}{Rc_0 - \vec{v} \cdot \vec{R}}, \quad \text{with } \vec{R} = \vec{r} - \vec{v}t_0. \quad (6.107)$$

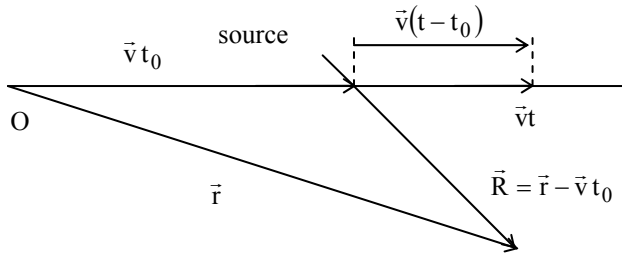

**Figure 6.5.** Moving punctual source (constant velocity  $\vec{v}$ )

6.3.1.2. Initial values problems

At any given point in an infinite medium, without any source, the values of the field  $\psi_0$  and its derivative with respect to the time  $v_0 = \partial\psi_0/\partial t_0$  are assumed known at  $t = t_i$ . The integral equation (6.60) becomes

$$\psi(\vec{r}, t) = \frac{1}{c_0^2} \iiint dD_0 \left[ G(\vec{r}, t; \vec{r}_0, t_i) v_0(\vec{r}_0) - \frac{\partial}{\partial t_i} G(\vec{r}, t; \vec{r}_0, t_i) \psi_0(\vec{r}_0) \right]. \quad (6.108)$$

This result is applied to three different problems: one-, two- and three-dimensions.

6.3.1.2.1. One dimensional initial values problems: infinite string *in vacuo*

The solution (6.108) then becomes

$$\psi(x, t) = \frac{1}{c_0^2} \int_{-\infty}^{+\infty} dx_0 \left[ G(x, t; x_0, t_i) v_0(x_0) - \frac{\partial}{\partial t_i} G(x, t; x_0, t_i) \psi_0(x_0) \right]. \quad (6.109)$$

The substitution of the Green's function (3.54) and its derivative (since  $1 - U(-u) = U(u)$ )

$$G(x, t; x_0, t_i) = \frac{c_0}{2} [1 - U(|x - x_0| - c_0(t - t_i))]$$

$$\text{and } \frac{\partial}{\partial t_i} G(x, t; x_0, t_i) = -\frac{c_0^2}{2} \delta(|x - x_0| - c_0(t - t_i)),$$

into equation (6.109) and writing  $t_1 = 0$  leads to

$$\psi(x, t) = \frac{1}{2} \left[ \frac{1}{c_0} \int_{x-c_0t}^{x+c_0t} v_0(x_0) dx_0 + \psi_0(x+c_0t) + \psi_0(x-c_0t) \right]. \quad (6.110)$$

It is the well-known D'Alembertian solution of the initial value problem at one-dimension. One can easily verify that it satisfies the considered problem. Indeed, by substituting, in the initial conditions, the general solution

$$F_1(x+c_0t) + F_2(x-c_0t) \quad (6.111)$$

to the vibrating string equation

$$\left[ \frac{\partial^2}{\partial x^2} - \frac{1}{c_0^2} \frac{\partial^2}{\partial t^2} \right] \psi(x, t) = 0,$$

where  $c_0^2 = T/m_\ell$  is the ratio of the tension of the string to the mass per unit length, leads to the following equations:

$$\begin{aligned} F_1(x) + F_2(x) &= \psi_0(x), \\ F_1'(x) - F_2'(x) &= \frac{1}{c_0} v_0(x). \end{aligned}$$

After integration with respect to  $x$ , the second equation becomes

$$F_1(x) - F_2(x) = \frac{1}{c_0} \int_{-\infty}^x v_0(x_0) dx_0,$$

and combined with the first equation leads to

$$F_1(x) = \frac{1}{2} \left[ \psi_0(x) + \frac{1}{c_0} \int_{-\infty}^x v_0(x_0) dx_0 \right],$$

$$\text{and } F_2(x) = \frac{1}{2} \left[ \psi_0(x) - \frac{1}{c_0} \int_{-\infty}^x v_0(x_0) dx_0 \right].$$



The solution is therefore

$$\begin{aligned} \psi(x, t) &= F_1(x + c_0t) + F_2(x - c_0t) \\ &= \frac{1}{2} \left[ \psi_0(x + c_0t) + \psi_0(x - c_0t) + \frac{1}{c_0} \int_{x-c_0t}^{x+c_0t} v_0(x_0) dx_0 \right]. \end{aligned} \quad (6.112)$$

i) *Case of the plucked string*

The tensioned string is released with a null initial velocity from an initial position defined by  $\psi_0(x_0)$  so that solution (6.112) is reduced to

$$\psi(x, t) = \frac{1}{2} [\psi_0(x + c_0t) + \psi_0(x - c_0t)]. \quad (6.113)$$

This result is illustrated by Figure 6.6: the continuous line represents the shape of the string while the dotted line represents the shapes of the partial waves in equation (6.113).

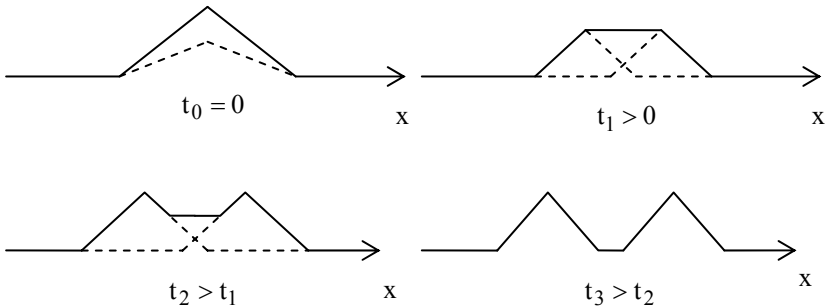

**Figure 6.6.** *The plucked string: deformed shape  $\psi(x, t_i)$*

ii) *Case of the hammered string*

The string is set into vibration with an initial velocity  $v_0(x_0)$  by an initial impact. The initial displacement is assumed null (string at rest). In the case where the impulse is uniformly distributed across a section  $(-a, +a)$  of string (Figure 6.7) and assuming a simple model for the hammer, the initial velocity is given by

$$v_0(x_0) = \begin{cases} v_0 & \text{if } x_0 \in (-a, a), \\ 0 & \text{if } x_0 \notin (-a, a). \end{cases}$$

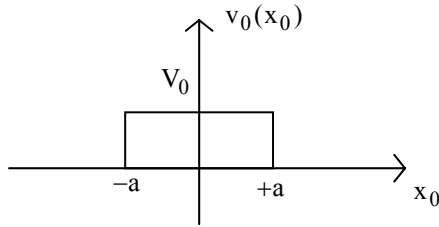

Figure 6.7. Initial velocity of the hammered string

The calculus of the solution at a few points and times is straightforward; some results are illustrated in Figure 6.8.

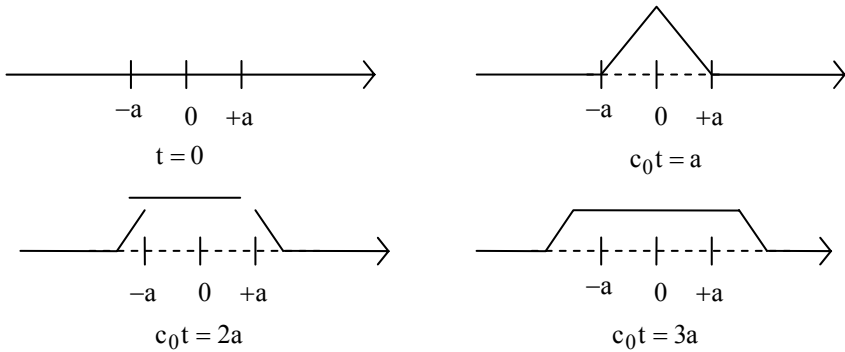

Figure 6.8. The hammered string: deformed shape  $\psi(x, t)$

6.3.1.2.2. Two-dimensional initial values problems: infinite membrane *in vacuo*

The origin  $O$  of the coordinates is located at the observation point and the origin of the time scale is  $t_i = 0$ . The substitution of the expression (3.49) of the two-dimensional Green's function into the solution (6.108) leads, since  $\partial G / \partial t_0 = -\partial G / \partial t$ , to

$$\begin{aligned} \psi(0, t) = \frac{1}{2\pi c_0} & \left[ \int_0^{2\pi} d\phi_0 \int_0^{c_0 t} w_0 dw_0 \frac{v_0(\bar{w}_0)}{\sqrt{c_0^2 t^2 - w_0^2}} \right. \\ & \left. + \frac{\partial}{\partial t} \int_0^{2\pi} d\phi_0 \int_0^{c_0 t} w_0 dw_0 \frac{\psi_0(\bar{w}_0)}{\sqrt{c_0^2 t^2 - w_0^2}} \right]. \end{aligned} \tag{6.114}$$

In the particular case of a membrane submitted to a tension  $T$ , of mass per unit area  $M_s$  satisfying the equation of propagation  $\left(\Delta - \frac{1}{c_0^2} \frac{\partial^2}{\partial t^2}\right)\psi = 0$  with  $c_0^2 = T/M_s$ , that is released with null initial velocity from a position given by  $\psi_0(\bar{w}_0) = \delta(\bar{w}_0 - \bar{w}_c)$ , the solution (6.114) can be written as

$$\begin{aligned} \psi(0, t) &= \frac{1}{2\pi c_0} \frac{\partial}{\partial t} \int_0^{2\pi} d\phi_0 \int_0^{c_0 t} w_0 dw_0 \frac{\delta(\bar{w}_0 - \bar{w}_c)}{\sqrt{c_0^2 t^2 - w_0^2}} \\ &= \begin{cases} \frac{1}{2\pi c_0} \frac{\partial}{\partial t} \left( \frac{1}{\sqrt{c_0^2 t^2 - w_c^2}} \right) & \text{if } w_c < c_0 t \\ 0 & \text{if } w_c > c_0 t \end{cases} = \frac{1}{2\pi c_0} \frac{\partial}{\partial t} \left( \frac{U(c_0 t - w_c)}{\sqrt{c_0^2 t^2 - w_c^2}} \right), \end{aligned}$$

$$\text{thus } \psi(0, t) = \frac{1}{2\pi} \left[ \frac{\delta(c_0 t - w_c)}{\sqrt{c_0^2 t^2 - w_c^2}} - \frac{c_0 t U(c_0 t - w_c)}{(c_0^2 t^2 - w_c^2)^{3/2}} \right]. \tag{6.115}$$

The signal  $\psi(0, t)$  is equal to zero until  $w_c = c_0 t$ . At this time an impulse signal reaches the observation point (the origin). This “impulse” is followed by a “trail” described by the second term which decreases as  $1/t^2$  for  $c_0 t \gg w_c$  (Figure 6.9). The original signal is therefore deformed during propagation.

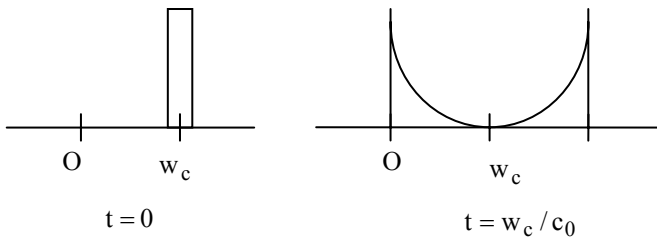

**Figure 6.9.** Propagation of an impulse signal in a membrane

### 6.3.1.2.3. Three-dimensional initial value problems

Once again, the origin of the coordinates coincides with the observation point. By using expression (3.40) of the Green's function, the solution is then written as

$$\psi(0, t) = \frac{1}{4\pi c_0^2} \iint d\Omega_0 \int dr_0 \left[ r_0 \delta\left(\frac{r_0}{c_0} - t\right) v_0(\vec{r}_0) - r_0 \delta'\left(\frac{r_0}{c_0} - t\right) \psi_0(\vec{r}_0) \right],$$

with  $d\Omega_0 = \sin\theta_0 d\theta_0 d\phi_0$ ,

consequently

$$\psi(0, t) = \frac{1}{4\pi} \iint d\Omega_0 \left( tv_0(c_0 t, \theta_0, \phi_0) + \frac{\partial}{\partial t} [t \psi_0(c_0 t, \theta_0, \phi_0)] \right). \quad (6.116)$$

There is no “trail”, the shape of the signal is conserved.

### 6.3.1.3. Huygens's principle

#### 6.3.1.3.1. The principle

Huygens's principle postulates that a given point of a wavefront acts as a point source radiating a spherical wave. The field at a given point and at a later time is then the sum of the fields radiated by each point source of the wavefront. The envelope created by these “wavelets” from elementary sources constitutes the new wavefront. This so called “principle” is solely a consequence of the equations of propagation. By assuming that in a domain (D) delimited by a surface ( $S_0$ ) there is no source and that the initial values of  $\psi$  and  $\partial\psi/\partial t$  are null, the integral equation (6.60) becomes

$$p(\vec{r}, t) = \frac{1}{4\pi} \int_{t_i}^{t^+} dt_0 \iint_{(S_0)} d\vec{S}_0 \left( \frac{1}{R} \delta\left[\frac{R}{c_0} - (t - t_0)\right] \text{grad}_0 p(\vec{r}_0, t_0) - p \text{grad}_0 \frac{1}{R} \delta\left[\frac{R}{c_0} - (t - t_0)\right] \right), \quad (6.117)$$

where  $\vec{R} = \vec{r} - \vec{r}_0$ .

The integral with respect to  $t_0$  in the first term is rather simple:

$$\int_{t_i}^{t^+} \frac{1}{R} \delta\left[\frac{R}{c_0} - (t - t_0)\right] \text{grad}_0 p(\vec{r}_0, t_0) dt_0 = \frac{1}{R} \text{grad}_0 p(\vec{r}_0, t - R/c_0).$$

The integration with respect to  $t_0$  is estimated as follows:

$$\begin{aligned}
 & \int_{t_i}^{t^+} p \operatorname{grad}_0 \left( \frac{1}{R} \delta \left[ \frac{R}{c_0} - (t - t_0) \right] \right) dt_0 \\
 &= \int_{t_i}^{t^+} p \frac{\partial}{\partial R} \left( \frac{1}{R} \delta \left[ \frac{R}{c_0} - (t - t_0) \right] \right) \operatorname{grad}_0 R dt_0, \\
 &= - \int_{t_i}^{t^+} p(\bar{r}_0, t_0) \frac{\bar{R}}{R^3} \left( -\delta \left[ \frac{R}{c_0} - (t - t_0) \right] + \frac{R}{c_0} \delta' \left[ \frac{R}{c_0} - (t - t_0) \right] \right) dt_0, \\
 &= \int_{t_i}^{t^+} \frac{\bar{R}}{R^3} \left( p(\bar{r}_0, t - R/c_0) + \frac{R}{c_0} \left[ \frac{\partial}{\partial t_0} p(\bar{r}_0, t_0) \right]_{t_0=t-R/c_0} \right) dt_0.
 \end{aligned}$$

The field within the surface ( $S_0$ ) is then written as

$$\begin{aligned}
 p(\bar{r}, t) = \frac{1}{4\pi} \iint_{(S_0)} d\bar{S}_0 \cdot & \left( \frac{1}{R} \operatorname{grad}_0 p(\bar{r}_0, t_0) \right. \\
 & \left. - \frac{\bar{R}}{R} \left[ \frac{1}{R^2} p(\bar{r}_0, t_0) + \frac{1}{c_0 R} \frac{\partial}{\partial t_0} p(\bar{r}_0, t_0) \right] \right)_{t_0=t-R/c_0}. \quad (6.118)
 \end{aligned}$$

Consequently, if a propagating field exists on the surface ( $S_0$ ) (coinciding or not with a wavefront) while the rest of the surface is projected to infinity or at least where the field is null, then the value of the field  $p$  at the point  $(\bar{r}, t)$  depends solely on the characteristics of the field “wavefront” at the time  $(t - R/c_0)$ . In other words, the effect of a wavefront on the field downstream and at a later time is equivalent to the effect of a source distribution on the surface of the “wavefront”. The characteristics of this distribution are (following the order of appearance of the terms in the above equation): those of a monopolar source the intensity of which is proportional to the gradient of  $p$  normal to the surface ( $S_0$ ) considered, and those of a dipolar source of directivity factor depending on  $(\bar{R} \cdot d\bar{S}_0)$  and the intensity of which depends on  $p$  and its derivative with respect to the time  $\partial p / \partial t$  taken at a point of the surface ( $S_0$ ).

## 6.3.1.3.2. Application to noise reduction

In principle, to reduce the field  $p(\vec{r}, t)$  (basis of noise reduction) one needs to set elementary sources on the surface ( $S_0$ ) which generate at  $(\vec{r}, t)$  a pressure  $p_a(\vec{r}, t)$  such that the sum of the existing field  $p(\vec{r}, t)$  and  $p_a(\vec{r}, t)$  is equal to zero:

$$p(\vec{r}, t) + p_a(\vec{r}, t) = 0. \quad (6.119)$$

Thus, at a given point  $\vec{r}_0$  of the surface ( $S_0$ ), the elementary “anti-noise” source must generate, at  $(\vec{r}, t)$ , the elementary pressure

$$\begin{aligned} dp_a(\vec{r}, t) &= -dp(\vec{r}, t), \\ &= \frac{d\vec{S}_0}{4\pi} \left[ \frac{1}{R} \text{grad}_0 p(\vec{r}_0, t_0) \right. \\ &\quad \left. - \frac{\vec{R}}{R} \left[ \frac{1}{R^2} p(\vec{r}_0, t_0) + \frac{1}{Rc_0} \frac{\partial}{\partial t_0} p(\vec{r}_0, t_0) \right] \right]_{t_0 = t - \frac{R}{c_0}}. \end{aligned} \quad (6.120)$$

Such a noise control device must therefore contain a layer of monopoles (omni-directional loudspeakers) at the surface ( $S_0$ ) emitting a field that is proportional to the incident normal particle velocity (factor  $d\vec{S}_0 \text{grad}_0 p$ ) and that can be detected by a bi-directional microphone of cosine directivity, and must also contain a layer of dipoles (bi-directional loudspeaker in  $\cos \theta = \frac{d\vec{S}_0 \cdot \vec{R}}{dS_0 R}$  that can be detected by an omni-directional microphone) over the same surface ( $S_0$ ) emitting a field proportional to the incident pressure and its time derivative. Also, it is the pressure field and its partial derivatives (time and space) over the “frontier” ( $S_0$ ) that “govern” the acoustic field considered. This is in accordance with the fundamental laws imposed on fields governed by second-order partial differential equations.

As regards of the complexity of the problem, the efficiency of such device in practice can only be partial and localized, the device itself being elementary with respect to the requirements of the theory (ignoring, in particular, its bulk, retro-diffusion and many imperfections). The description given above of a noise control device is far from being exhaustive and better-suited approaches exist regarding the local attenuation of the sound levels in real situations.

### 6.3.2. Examples of application in the frequency domain

#### 6.3.2.1. Harmonic motion of a membrane stretched in a rigid frame

The normal displacement field  $W$  of a membrane of surface  $S$ , stretched in a rigid frame of perimeter  $C$  satisfies the following problem:

$$\left( T\Delta - M_S \frac{\partial^2}{\partial t^2} \right) W = -f(\vec{r}, t), \quad \text{over } S, \quad (6.121a)$$

$$W = 0 \quad \text{over } C, \quad (6.121b)$$

where  $T$  denotes the tension of the membrane,  $M_S$  its mass per unit of area and  $f(\vec{r}, t)$  the force per unit area exerted onto the membrane.

For a harmonic excitation  $f(\vec{r}, t) = f_0(\vec{r})e^{i\omega t}$ , the solution takes the form  $W_0(\vec{r})e^{i\omega t}$  (with  $\partial^2 / \partial t^2 \equiv -\omega^2$ ). The associated eigenvalue problem is then

$$(\Delta + k_m^2)\Psi_m = 0 \quad \text{over } (S), \quad (6.122a)$$

$$\Psi_m = 0, \quad \text{over } C, \quad (6.122b)$$

where  $m$  is actually a double index.

The eigenfrequencies are

$$v_m = \frac{c_0 k_m}{2\pi},$$

where  $c_0 = \sqrt{T/M_S}$  denotes the speed of the waves.

The associated solution to the Green's problem

$$(\Delta + k_0^2)G(\vec{r}, \vec{r}_0) = -\delta(\vec{r}, \vec{r}_0), \quad \text{over } (S)$$

$$G(\vec{r}, \vec{r}_0) = 0, \quad \text{over } C,$$

can then be written as an expansion in the basis of eigenfunctions  $\psi_m$  assumed normalized to the unit (equation (6.20)),

$$G(\vec{r}, \vec{r}_0) = \sum_m \frac{\psi_m(\vec{r}_0)}{k_m^2 - k_0^2} \psi_m(\vec{r}), \quad k_0 = \omega/c_0, \quad (6.123)$$

and the solution (6.121), in the Fourier domain, is (equation (6.63) in two dimensions)

$$W_0(\vec{r}) = \frac{1}{T} \iint_{(S)} G(\vec{r}, \vec{r}_0) f_0(\vec{r}_0) dS_0. \quad (6.124)$$

The integral at the boundary (over the contour  $C$ ) vanishes since the admitted Green's function satisfies the same boundary conditions as the present solution.

Finally, the substitution of equation (6.123) of the Green's function into equation (6.124), gives

$$W_0(\vec{r}) = \frac{1}{T} \sum_m \frac{1}{k_m^2 - k_0^2} \iint_{(S)} \psi_m(\vec{r}_0) f_0(\vec{r}_0) dS_0 \psi_m(\vec{r}), \quad (6.125)$$

that is an expansion in the basis of the eigenfunctions  $\psi_m$ , the coefficient of which introduces the condition of resonance ( $k_0 = k_m$ ) as well as the energy transfer from the source (of intensity  $f_0$ ) to the  $m^{\text{th}}$  mode (scalar product  $\iint_{(S)} \psi_m(\vec{r}_0) f_0(\vec{r}_0) dS_0$ ).

Note: a solution in the form of a modal expansion, by substitution in equation (6.121a), of eigenfunctions satisfying the Dirichlet's boundary conditions (6.121b), can be estimated by writing that

$$\iint_{(S)} \psi_v(\vec{r}) (T\Delta + M_s \omega^2) \sum_m A_m \psi_m(\vec{r}) dS = - \iint_{(S)} \psi_v(\vec{r}) f_0(\vec{r}) d\vec{r},$$

$$\text{or } \sum_m (-k_m^2 + k_0^2) A_m \iint_{(S)} \psi_v(\vec{r}) \psi_m(\vec{r}) dS = - \frac{1}{T} \iint_{(S)} \psi_v(\vec{r}) f_0(\vec{r}) d\vec{r},$$

thus

$$A_v = \frac{1}{T} \frac{\iint_{(S)} \psi_v(\vec{r}) f_0(\vec{r}) d\vec{r}}{k_v^2 - k_0^2}, \quad (6.126)$$

leading directly to the solution (6.125).



For a rectangular membrane of dimensions  $(a, b)$ , the origin being taken at a corner, one can easily verify that

$$\psi_{mn} = \frac{2}{\sqrt{ab}} \sin \frac{m\pi x}{a} \sin \frac{n\pi y}{b}, \tag{6.127a}$$

$$v_{mn} = \frac{c_0}{2} \sqrt{\left(\frac{m}{a}\right)^2 + \left(\frac{n}{b}\right)^2}. \tag{6.127b}$$

6.3.2.2. *Acoustic field in a “small” cavity (Fourier domain)*

The objective of this section is to justify, in cavities the dimensions of which are small compared to the considered wavelength  $\lambda_0$ , the hypothesis of uniformity of the pressure field made in section 3.5. This condition can also be written as  $\lambda_0 \gg \sqrt[3]{V}$  where  $V$  denotes the volume of the cavity. The effects of viscosity and thermal conduction are herein ignored. The hypotheses are the same as those made in section 3.5 according to which the acoustic field in the cavity is generated simultaneously by the vibration velocity of the walls  $v_n$  outward the cavity (that eventually vanishes locally) and by a source of thermal energy generating the heat quantity  $h$  per units of mass and time. The wall material is characterized by its acoustic impedance  $Z = \rho_0 c_0 / \beta$  so that the boundary condition takes the general following form (1.70):

$$\frac{\partial p}{\partial n} + ik_0 \beta p = -i\omega \rho_0 v_n, \tag{6.128}$$

where  $k_0 = \omega/c_0$  (hereinafter  $k_m$  is denoted  $k_{m=0}$  for  $m = 0$ ).

The solution to the problem is obtained from the integral equation (6.63). The Green’s function is chosen satisfying Neumann’s conditions and expanded in the basis of eigenfunctions  $\psi_m$  (using a compatible geometry) which also satisfy Neumann’s conditions. Consequently

$$p(\vec{r}) = \sum_m \frac{\psi_m(\vec{r})}{k_m^2 - k_0^2} \left[ \frac{i\omega \rho_0 \alpha}{C_p} \iiint_{(V)} h(\vec{r}_0) \psi_m(\vec{r}_0) d\vec{r}_0 - ik_0 \rho_0 c_0 \iint_{(S)} v_n(\vec{r}_0) \psi_m(\vec{r}_0) dS_0 - ik_0 \iint_{(S)} \beta(\vec{r}_0) \psi_m(\vec{r}_0) p(\vec{r}_0) dS_0 \right]. \tag{6.129}$$

For  $m \geq 1$ , the expansion coefficients are proportional to the reciprocal of  $(k_m^2 - k_0^2)$  so that, for  $k_0 \ll k_1$  (“small” cavity), the first coefficient ( $m = 0$ ) is

predominant. Also, for  $m = 0$ ,  $\psi_{m=0} = 1/\sqrt{V}$  is independent of the point  $\vec{r}$  considered and  $k_{m=0} = 0$ , the solution becomes

$$p(\vec{r}) = \frac{i\psi_0^2}{k_0} \left[ -\frac{\rho_0 c_0 \hat{\beta} \chi_T}{C_p} \iiint_{(V)} h(\vec{r}_0) d\vec{r}_0 + \rho_0 c_0 \iint_{(S)} v_n(\vec{r}_0) dS_0 + \iint_{(S)} \beta(\vec{r}_0) p(\vec{r}_0) dS_0 \right]. \quad (6.130)$$

The right-hand side term does not depend on the variable  $\vec{r}$  and, consequently, the pressure  $p(\vec{r})$  is independent of the point considered in the cavity. The hypothesis of uniformity of the pressure field in the cavity is hereby justified. If one considers a uniform heat quantity  $h$  (or by simply considering its mean value), equation (6.130) becomes

$$p = \frac{i\psi_0^2}{k_0} \left[ -\frac{1}{C_p} \rho_0 c_0 \hat{\beta} \chi_T V h + \rho_0 c_0 U_n + p \rho_0 c_0 S / \bar{Z} \right], \quad (6.131)$$

where  $U_n = \iint_{(S)} v_n(\vec{r}_0) dS_0$  denotes the total flow from the wall, and

where  $\frac{\rho_0 c_0 S}{\bar{Z}} = \iint_{(S)} \beta(\vec{r}_0) dS_0$  introduces the global effect of the wall impedance.

By denoting  $\rho_0 c_0^2 = \gamma / \chi_T$ ,  $\psi_0^2 = 1/V$  and  $U_n = i\omega \delta V$ , the result (6.131) becomes

$$p = \frac{-\frac{\gamma \delta V}{\chi_T V} + \frac{\gamma \hat{\beta} h}{i\omega C_p}}{1 + \frac{\gamma S / V}{i\omega \chi_T \bar{Z}}}. \quad (6.132)$$

Solution (6.132) is nothing more than the solution given by equation (3.73) in which the effects of thermal dissipation are ignored. In the present context these effects could only be introduced as thermal impedance as in equation (3.10)

$$\frac{\rho_0 c_0}{Z_h} = \sqrt{ik_0} (\gamma - 1) \sqrt{\ell_h}.$$

The factor depending on  $\bar{Z}$  in equation (6.132) would then be replaced by the term of “impedance”

$$\frac{\gamma(S/V)\sqrt{i}\sqrt{k_0}(\gamma-1)\sqrt{\ell_h}}{i\omega\chi_T\rho_0c_0} = \frac{1-i}{\sqrt{2}}(\gamma-1)\frac{S}{V}\sqrt{\frac{c_0\ell_h}{\omega}}, \tag{6.133}$$

which is in accordance with result (3.73).

6.3.2.3. Radiation from an oscillating plane surface in an infinite space

6.3.2.3.1. The problem and its solution

A plane circular surface of radius  $a$ , assumed infinitely thin, set in the  $(x, y)$ -plane and centered at the origin of the coordinate system (Figure 6.10) is in harmonic motion and to which is consequently applied a force on the surrounding fluid to which the acoustic pressure generated on both sides is related to by

$$dF = (p_+ - p_-)dS = 2p_+dS, \tag{6.134}$$

where  $dF = dF_z$  represents the elementary normal force exerted by the disk on the fluid,  $dS$  represents an element of surface of the source, and  $p_+$  and  $p_-$  the acoustic pressures at the surface of the disk at respectively,  $z < 0$  and  $z > 0$ , and such that

$$p_+ = -p_-. \tag{6.135}$$

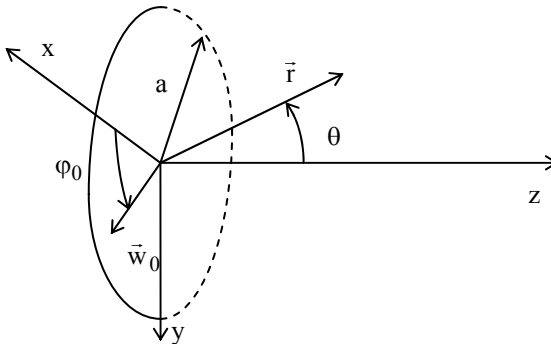

**Figure 6.10.** Oscillating plane surface into an infinite space and associated coordinate system (case of the disk)

The velocity of the oscillating surface, equal to the particle velocity at the surface of the disk (normal to the disk), is given by

$$v_{n_0^+} = \frac{i}{\rho_0 \omega} \frac{\partial p}{\partial n_0^+} = \frac{-i}{\rho_0 \omega} \frac{\partial p}{\partial z} = -v_z, \quad z = 0^+, \quad (6.136a)$$

$$v_{n_0^-} = \frac{i}{\rho_0 \omega} \frac{\partial p}{\partial n_0^-} = \frac{i}{\rho_0 \omega} \frac{\partial p}{\partial z} = v_z, \quad z = 0^-, \quad (6.136b)$$

where  $n_0^+$  and  $n_0^-$  denote the normal unit vectors orientated respectively in the negative and positive  $z$ -directions.

Assuming Sommerfeld's condition at infinity and using the integral formalism, the problem becomes (equation (6.63) with a null triple integral)

$$p(\vec{r}) = \iint_{(S)} \left( G(\vec{r}, \vec{r}_0) \left[ \frac{\partial p(\vec{r}_0)}{\partial n_0^+} + \frac{\partial p(\vec{r}_0)}{\partial n_0^-} \right] - \left[ p_+(\vec{r}_0) \frac{\partial G(\vec{r}, \vec{r}_0)}{\partial n_0^+} + p_-(\vec{r}_0) \frac{\partial G(\vec{r}, \vec{r}_0)}{\partial n_0^-} \right] \right) dS_0 \quad (6.137)$$

where the Green's function chosen satisfies Sommerfeld's condition:

$$G(\vec{r}, \vec{r}_0) = \frac{e^{-ik|\vec{r}-\vec{r}_0|}}{4\pi|\vec{r}-\vec{r}_0|}. \quad (6.138)$$

The sum of the positive and negative indexes makes possible, by simple integration over the oscillating surface  $S_0$ , the integration of both sides of the disk at once. According to equations (6.135) and (6.136), taken at  $z = 0^+$  or  $z = 0^-$ ,

$$\begin{aligned} \frac{\partial p(\vec{r}_0)}{\partial n_0^+} + \frac{\partial p(\vec{r}_0)}{\partial n_0^-} &= v_z - v_z = 0, \\ -p_+ \frac{\partial G}{\partial n_0^+} - p_- \frac{\partial G}{\partial n_0^-} &= (p_+ - p_-) \frac{\partial G}{\partial z_0} = 2p_+ \frac{\partial G}{\partial z_0} = \frac{dF}{dS} \frac{\partial G}{\partial z_0}, \end{aligned}$$

and equation (6.137) becomes

$$p(\vec{r}) = \iint_{(S)} \frac{dF}{dS_0} \frac{\partial}{\partial z_0} \left( \frac{e^{-ik|\vec{r}-\vec{r}_0|}}{4\pi|\vec{r}-\vec{r}_0|} \right) dS_0, \quad (6.139)$$

where  $|\vec{r} - \vec{r}_0| = \sqrt{(x - x_0)^2 + (y - y_0)^2 + z^2}$ . Since the operator  $(\partial/\partial z_0)$  is acting on the Green's function, the field presents the characteristics of a dipolar field.

### 6.3.2.3.2. Far field: particular case of the oscillating disk

The oscillating surface is a disk of radius  $a$  (Figure 6.10).

For  $r_0 \equiv w_0 < a \ll r$ ,

$$|\vec{r} - \vec{r}_0| = \sqrt{r^2 + r_0^2 - 2\vec{r} \cdot \vec{r}_0} \approx r - \frac{\vec{r} \cdot \vec{r}_0}{r},$$

or, in cylindrical coordinates  $(w_0, \varphi_0, z_0)$ ,

$$|\vec{r} - \vec{r}_0| \approx r - w_0 \sin \theta \cos(\varphi_0 - \varphi) - z_0 \cos \theta, \quad (6.140)$$

and finally, ignoring the term in  $1/r^2$ :

$$\begin{aligned} \left. \frac{\partial G}{\partial z_0} \right)_{z_0=0} &= \frac{1}{4\pi} e^{-ik[r - w_0 \sin \theta \cos(\varphi_0 - \varphi)]} \\ &\times \frac{\partial}{\partial z_0} \left[ \frac{e^{ikz_0 \cos \theta}}{r - w_0 \sin \theta \cos(\varphi_0 - \varphi) - z_0 \cos \theta} \right]_{z_0=0}, \\ &= \frac{ik \cos \theta}{4\pi r} e^{-ik[r - w_0 \sin \theta \cos(\varphi_0 - \varphi)]}. \end{aligned}$$

At infinity, assuming that  $dF/dS$  is independent of the location on the disk ( $dF/dS \approx F/\pi a^2$ ), the acoustic field becomes

$$\begin{aligned} p_\infty(\vec{r}) &= \frac{F}{\pi a^2} ik \cos \theta \frac{e^{-ikr}}{4\pi r} \int_0^a w_0 dw_0 \int_0^{2\pi} d\varphi_0 e^{-ik w_0 \sin \theta \cos(\varphi_0 - \varphi)}, \\ &= ik F \frac{e^{-ikr}}{4\pi r} \frac{2J_1(ka \sin \theta)}{ka \sin \theta} \cos \theta, \end{aligned} \quad (6.141)$$

where  $F$  denotes the total force exerted on the fluid.

If the wavelength is greater than the diameter of the disk (approximately):  $ka \sin \theta \leq 1$  and  $\frac{2J_1(ka \sin \theta)}{ka \sin \theta} \simeq 1$ ; expression (6.141) then represents the far field generated by a dipole of dipolar moment  $M_0 = F/(ik_0 \rho_0 c_0)$  (i.e. equation (5.164)).

The pressure field is null in the plane defined by  $\theta = \pi/2$  (plane of the disk). Finally, when the dimensions of the disk are small compared to the wavelength ( $ka \rightarrow 0$ ), the pressure field tends to zero; to guarantee radiation from a surface, the dimensions of the disk must not be small compared to the wavelength.

### 6.3.2.3.3. Radiation impedance of the disk

The radiation impedance is the ratio of the force exerted by a face of the disk onto the fluid to the mean velocity of the disk

$$Z = \frac{F/2}{\bar{v}_0}, \quad (6.142)$$

$$\text{where } \bar{v}_0 = \frac{1}{\pi a^2} \iint v_0 w \, dw \, d\varphi.$$

The substitution of expression (6.139) of the pressure  $p$  into the expression of the particle velocity

$$v_0 = \left. \frac{i}{k_0 \rho_0 c_0} \frac{\partial p}{\partial z} \right)_{z=0}$$

leads to the mean vibration velocity of the disk

$$\bar{v}_0 = \frac{2i}{a^2 k_0 \rho_0 c_0} \int_0^a w \, dw \int_0^{2\pi} d\varphi_0 \int_0^a w_0 \, dw_0 \frac{F}{\pi a^2} \frac{\partial}{\partial z} \frac{\partial}{\partial z_0} \frac{e^{-ik|\bar{r}-\bar{r}_0|}}{4\pi|\bar{r}-\bar{r}_0|}. \quad (6.143)$$

By using the double expansion (discrete and continuous)

$$\frac{e^{-ik|\bar{r}-\bar{r}_0|}}{4\pi|\bar{r}-\bar{r}_0|} = \sum_{m=0}^{\infty} \frac{-i}{4\pi} (2 - \delta_{m_0}) \cos[m(\varphi - \varphi_0)] \times \int_{-\infty}^{+\infty} J_m(\chi w_0) J_m(\chi w) \frac{\chi d\chi}{\sigma} e^{-i\sigma|z-z_0|} \quad (6.144)$$

with  $\sigma = \sqrt{k^2 - \chi^2}$  if  $\chi < k$  or  $(-i)\sqrt{\chi^2 - k^2}$  if  $\chi > k$ , the estimation of the integrals in equations (6.143) leads to the expression of the radiation impedance  $Z$  (6.142):

$$Z = \frac{\pi a^2 \rho_0 c_0}{\frac{2}{k_0} \int_0^\infty \frac{\sigma}{\chi} J_1^2(\chi a) d\chi} \tag{6.145}$$

The profile of the real and imaginary parts of this impedance is presented in Figure 6.11 as a function of the dimensionless parameter ( $ka$ ). The real part tends to zero (horizontal tangent) when ( $ka$ ) tends to zero. This shows that the radiated energy vanishes when the wavelength considered becomes great in relation to the dimensions of the radiating surface.

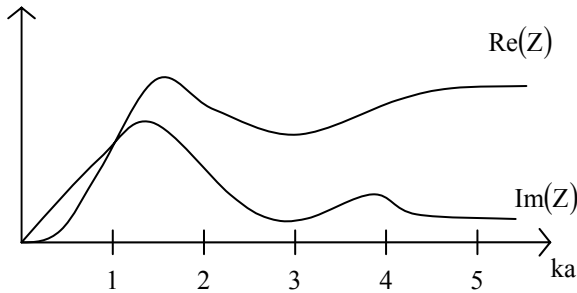
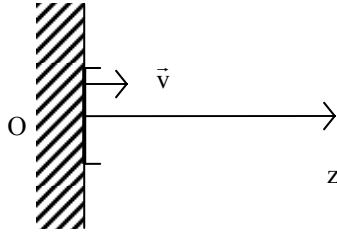

**Figure 6.11.** Radiation impedance of a vibrating disk in an infinite space

6.3.2.4. Radiation impedance of a vibrating surface in an infinite rigid screen

6.3.2.4.1. Problem and solution

A plane circular surface of radius  $a$ , centered at the origin of the cylindrical coordinate system ( $w, \varphi, z$ ) is at the immediate vicinity of an infinite rigid screen in the plane perpendicular to the  $\vec{Oz}$  axis. It is harmonically vibrating with a velocity  $v$ , function of the point considered. The domain considered occupied by the acoustic field is the half-space  $z > 0$  (Figure 6.12).



**Figure 6.12.** *Vibrating plane surface in an infinite rigid screen*

By assuming Sommerfeld's condition at infinity ( $z \rightarrow \infty$ ) and using the Green's function described by equation (6.7b) satisfying Neumann's conditions at  $z = 0$ ,

$$G(\vec{r}, \vec{r}_0) = \frac{e^{-ik|\vec{r}-\vec{r}_0|}}{4\pi|\vec{r}-\vec{r}_0|} + \frac{e^{-ik|\vec{r}-\vec{r}_0'|}}{4\pi|\vec{r}-\vec{r}_0'|},$$

where  $\vec{r}_0'$  is the image of  $\vec{r}_0$  by symmetry with respect to the screen (plane  $z = 0$ ), the integral equation is reduced to the following surface integral:

$$p(\vec{r}) = - \iint_{(S)} G(\vec{r}, \vec{r}_0) \frac{\partial p(\vec{r}_0)}{\partial z_0} w_0 dw_0 d\phi_0.$$

Since the vibration velocity at the boundary ( $S$ ) is null outside of the vibrating surface ( $S_0$ ), the solution can then be written, since  $\vec{r}_0' = \vec{r}_0$  at  $z = 0$ , as

$$p(\vec{r}) = \frac{ik_0 \rho_0 c_0}{2\pi} \iint_{(S_0)} dS_0 \frac{e^{-ik|\vec{r}-\vec{r}_0|}}{|\vec{r}-\vec{r}_0|} v(\vec{r}_0) \text{ for } z > 0. \quad (6.146)$$

Equation (6.146) is the well-known Rayleigh equation or Huygens-Rayleigh equation representing a monopolar field.

Note: this result is widely used; it is a model of systems radiating from one face (including loudspeakers), the "back" wave being isolated from the "face" wave by a screen or an opaque enclosure.

#### 6.3.2.4.2. Far field of an oscillating piston: the disk

In the case where the vibration velocity is independent of the point considered on the disk (oscillating piston), the expression (6.146) of the acoustic pressure in the far-field (equation (6.140)) is



$$p = ik_0 \rho_0 c_0 v \frac{e^{-ikr}}{2\pi r} \int_0^{2\pi} d\phi_0 \int_0^a w_0 dw_0 e^{ik w_0 \sin \theta \cos(\phi_0 - \phi)},$$

thus

$$p = i2\pi a^2 v k_0 \rho_0 c_0 \frac{e^{-ikr}}{4\pi r} \frac{2J_1(ka \sin \theta)}{ka \sin \theta}. \tag{6.147}$$

The corresponding radial intensity (1.84) is

$$I_{r\infty} = \frac{|p|^2}{2\rho_0 c_0} = \frac{\rho_0 c_0}{8} |v|^2 \frac{k_0^2 a^4}{r^2} \left| \frac{2J_1(ka \sin \theta)}{ka \sin \theta} \right|^2.$$

The field presents the characteristics of a monopolar field; however, it is influenced by the directivity factor the variability of which, with respect to  $\theta$ , increases as  $ka$  increases.

#### 6.3.2.4.3. Radiation impedance

By assuming once again that the vibration velocity is independent of the point considered on the disk, the substitution of equation (6.144) into equation (6.146) gives

$$p = k_0 \rho_0 c_0 a v \int_0^\infty J_0(\chi w) J_1(\chi a) \frac{d\chi}{\chi}, \tag{6.148}$$

since

$$\int_0^{2\pi} \cos[m(\phi - \phi_0)] d\phi_0 = 2\pi \delta_{m0} \quad \text{and} \quad \int_0^a w_0 dw_0 J_0(\chi w_0) = \frac{a}{\chi} J_1(\chi a).$$

Consequently, the mean force exerted onto the fluid by the disk is written

$$\begin{aligned} F &= 2\pi \int_0^a p(w) w dw = 2\pi \rho_0 c_0 k_0 a^2 v \int_0^\infty J_1^2(\chi a) \frac{d\chi}{\chi \sigma}, \\ &= 2\pi a^2 \rho_0 c_0 k_0 v \left[ \int_0^k \frac{J_1^2(\chi a) d\chi}{\chi \sqrt{k^2 - \chi^2}} + i \int_k^\infty \frac{J_1^2(\chi a) d\chi}{\chi \sqrt{\chi^2 - k^2}} \right]. \end{aligned} \tag{6.149}$$

Finally, the expression of the radiation impedance  $Z = F/v$  can be written in the common form

$$Z = \pi a^2 \rho_0 c_0 \left[ 1 - \frac{J_1(2ka)}{ka} + i \frac{S_1(2ka)}{ka} \right], \quad (6.150)$$

where the function  $S_1(2ka)$  denotes Struve's function.

Close to the origin ( $ka \rightarrow 0$ ), expression (6.150) of the impedance can be written, at the lowest orders, as

$$Z_0 \approx \pi a^2 \rho_0 c_0 \left[ \frac{1}{2} (k_0 a)^2 + i \frac{8k_0 a}{3\pi} \right] \approx i \pi a^2 \rho_0 c_0 \frac{8k_0 a}{3\pi}, \quad (6.151)$$

and, for small wavelengths ( $ka \rightarrow \infty$ ),

$$Z_\infty \approx \pi a^2 \rho_0 c_0 \left[ 1 + i \frac{2}{\pi k_0 a} \right] \approx \pi a^2 \rho_0 c_0, \quad (6.152)$$

with  $\pi a^2 = S_0$  where  $a = \sqrt{S_0/\pi}$ ,  $S_0$  denoting the area of the radiating surface.

The comment at the end of the previous section (6.3.2.4.2) is valid for these two results. The profiles of the real and imaginary parts of the radiation impedance present the same characteristics as those given by Figure 6.11 (even though the curves are different). When the dimensions of the disk are considerably smaller than the wavelength ( $ka \ll 1$ ), the radiated energy flow tends to zero (the impedance becomes a pure imaginary, a quadratic relationship exists then between the force  $F$  and the velocity  $v$ ) and the acoustic pressure  $p$  (6.147) is the pressure of a monopole since

$$\lim_{ka \rightarrow 0} \frac{2J_1(ka \sin \theta)}{ka \sin \theta} = 1. \quad (6.153)$$

### 6.3.2.5. Radiation from a loudspeaker

#### 6.3.2.5.1. Radiation from a loudspeaker in two half-spaces separated by a finite plane screen

A small loudspeaker, modeled as a point at the origin of the coordinate system, is located at the centre of a circular plane screen of radius ( $a$ ) at  $z = 0$  (Figure 6.12 with a circular screen). According to the conclusions of two of the previous sections

6.3.2.3 and 6.3.2.4), the field generated by a loudspeaker is approximated by the field of a monopole at the vicinity of the screen and by a dipole in the  $z = 0$  plane outside the screen ( $r > a$ ). These approximations make possible, by separating the domain considered into two sub-domains  $z > 0$  and  $z < 0$ , a simple expression of the field at the interface between the two sub-domains and an explicit form of the boundary integral in the integral equation.

The calculation of the field in the sub-domain  $z > 0$  is reduced to the integral over the surface  $S_0$  of the screen

$$p(\vec{r}) = \iint_{(S_0)} p(\vec{r}_0) \frac{\partial G(\vec{r}, \vec{r}_0)}{\partial z_0} dS_0, \quad (6.154)$$

since the field is assumed to present dipolar characteristics outside of the screen, but in the same plane, resulting in a null pressure for  $z = 0$  and  $r > a$ , and since the Green's function vanishes at  $z = 0$  (Dirichlet's condition):

$$G(\vec{r}, \vec{r}_0) = \frac{e^{-ik|\vec{r}-\vec{r}_0|}}{4\pi|\vec{r}-\vec{r}_0|} - \frac{e^{-ik|\vec{r}-\vec{r}'_0|}}{4\pi|\vec{r}-\vec{r}'_0|}, \quad (6.155)$$

where  $\vec{r}'_0$  is the image of  $\vec{r}_0$  with respect to the plane  $z = 0$ ,

According to equation (5.111), at  $z_0 = 0$ ,

$$\left. \frac{\partial G}{\partial z_0} \right)_{z_0=0} = -2 \cos(\vec{n}_0, \vec{r} - \vec{r}_0) ik_0 \left[ 1 + \frac{1}{ik_0|\vec{r}-\vec{r}_0|} \right] \frac{e^{-ik|\vec{r}-\vec{r}_0|}}{4\pi|\vec{r}-\vec{r}_0|}, \quad (6.156)$$

and, in the far field region ( $r \gg a$ ) at the vicinity of the  $\vec{Oz}$  axis ( $\cos(\vec{n}_0, \vec{r} - \vec{r}_0) \approx 1$ ),

$$\left. \frac{\partial G}{\partial z_0} \right)_{z_0=0} \simeq \frac{ik_0}{2\pi|\vec{r}-\vec{r}_0|} e^{-ik|\vec{r}-\vec{r}_0|}. \quad (6.157)$$

Finally, writing that at the screen the field is similar to that from a monopole,

$$p(r_0) = \frac{ik_0 \rho_0 c_0 Q_+}{2\pi} \frac{e^{-ikr_0}}{r_0}, \quad (6.158)$$

where  $Q_+$  denotes the strength of a pulsing half-sphere (monopolar)  $z > 0$ , the far field on the axis of the system is given by the approximated expression

$$p_\infty = \frac{k_0^2 \rho_0 c_0 Q_+}{2\pi} \int_0^a \frac{e^{-ik(|\vec{r}-\vec{r}_0|+r_0)}}{|\vec{r}-\vec{r}_0|} dr_0, \quad (6.159)$$

or, since  $|\vec{r}-\vec{r}_0| \approx r$ , by

$$p_\infty \approx \frac{k_0^2 \rho_0 c_0 Q_+}{2\pi} \frac{e^{-ikr}}{r} \int_0^a e^{-ikr_0} dr_0 = \frac{-k_0 \rho_0 c_0 Q_+}{\pi r} e^{-ik\left(r+\frac{a}{2}\right)} \sin \frac{k_0 a}{2}. \quad (6.160)$$

Apart from the effect of the factor  $\sin\left(\frac{k_0 a}{2}\right)$ , equation (6.160) expresses the monopolar property (the loudspeaker is modeled as a point source from the beginning). When the wavelength  $\lambda$  is such that  $a = n\lambda$  ( $n$  being an integer),  $\sin(k_0 a/2) = 0$ . In such case, the “back” and “front” waves, then out of phase, interfere in the far field region on the axis of the system.

To avoid these destructive interferences during the experimental characterization of loudspeakers, and to obtain smoother and significant response curves of the behavior of loudspeakers, the standards on measuring these characteristics specify that the screen (required to avoid an acoustic short circuit) cannot be symmetrical and that the loudspeaker cannot located at the center of the screen.

#### 6.3.2.5.2. Radiation from vibrating plane piston in an infinite plane screen: far field

##### i) Problem

A radiating plane surface, with a vibration velocity independent of the point of observation, is framed in a perfectly rigid infinite screen. The radiated pressure field is given by Rayleigh’s integral (6.146) as

$$p(\vec{r}) = \frac{ik_0 \rho_0 c_0}{2\pi} \iint_{(S_0)} \frac{e^{-ik|\vec{r}-\vec{r}_0|}}{|\vec{r}-\vec{r}_0|} v(\vec{r}_0) dS_0. \quad (6.161)$$

The coordinate system is given in Figure 6.13.

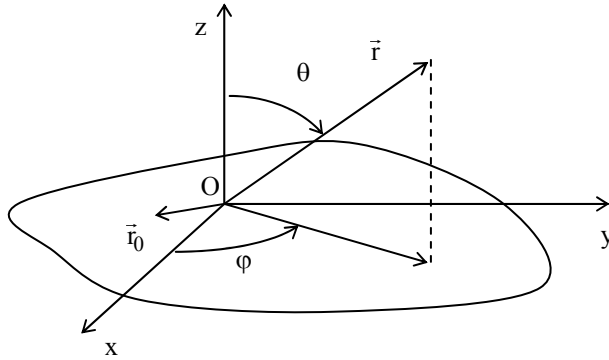

Figure 6.13. Coordinate system and notations

Here, the analysis is limited to the far field, consequently the following approximation (see equation (5.180)) holds

$$|\vec{r} - \vec{r}_0| = r \left[ 1 - \frac{\rho_0}{r} + \frac{1}{2} \left[ \left( \frac{r_0}{r} \right)^2 - \left( \frac{\rho_0}{r} \right)^2 \right] \right], \tag{6.162}$$

with

$$\begin{aligned} \rho_0 &= \hat{x}x_0 + \hat{y}y_0, \\ \hat{x} &= x / r = \sin \theta \cos \phi, \\ \hat{y} &= y / r = \sin \theta \sin \phi, \end{aligned}$$

since, at the second order of  $r_0 / r$ ,

$$|\vec{r} - \vec{r}_0| = \sqrt{r^2 + r_0^2 - 2\vec{r} \cdot \vec{r}_0} = r \sqrt{1 - 2 \frac{\vec{r} \cdot \vec{r}_0}{r^2} + \frac{r_0^2}{r^2}}.$$

ii) Expression “ $p_0$ ” of “ $p$ ” at the order zero of  $r_0 / r$

The integral (6.161) gives the pressure field  $p$ , generated at a point  $\vec{r}$  by the plane surface  $S_0$  (the location of a point of the vibrating surface is denoted  $\vec{r}_0$ ). At the 0<sup>th</sup> order, the pressure field is

$$p_0 = i \frac{k_0 \rho_0 c_0 Q}{2\pi} \frac{e^{-ikr}}{r}, \tag{6.163}$$

where  $Q = \iint_{(S_0)} v dS_0 = v S_0$  denotes the strength of the source (spherical source).

iii) *Fraunhofer's approximation: integral expression of "p" at the first order of  $r_0 / r$*

At the first order of  $r_0 / r$ , and considering equation (6.162), integral (6.161) becomes

$$p = ik_0 \rho_0 c_0 \frac{e^{-ikr}}{2\pi r} \iint_{(S_0)} e^{ik(x_0 \hat{x} + y_0 \hat{y})} v dS_0 .$$

For a vibrating surface (only one side) of length  $\ell$  and elementary width  $\delta y_0$  (i.e. column of loudspeakers), the solution becomes

$$\begin{aligned} p &= ik_0 \rho_0 c_0 \frac{e^{-ikr}}{2\pi r} v \delta y_0 \int_{-\ell/2}^{+\ell/2} e^{ik(x_0 \hat{x})} dx_0 , \\ &= i \frac{k_0 \rho_0 c_0}{2\pi} Q \frac{e^{-ikr}}{r} \frac{\sin(k\hat{x}\ell/2)}{(k\hat{x}\ell/2)} , \end{aligned} \quad (6.164)$$

where  $Q = v \ell \delta y_0$  denotes the strength of the source.

In the plane perpendicular to the "column" and passing through its center ( $\varphi = \pm\pi/2$  or  $\theta = 0$ ),

$$\frac{\sin(k\hat{x}\ell/2)}{(k\hat{x}\ell/2)} = 1 ,$$

the radiated field exhibits then a "spherical behavior" (at the first order). The "correction" to the spherical field, for a more accurate solution of the real field, is therefore a second-order quantity.

For a disk of radius "a", the far field is given by equation (6.147):

$$p = i \frac{k_0 \rho_0 c_0 Q}{2\pi} \frac{e^{-ikr}}{r} \frac{2J_1(ka \sin \theta)}{ka \sin \theta} , \quad (6.165)$$

where  $Q = \pi a^2 v$  denotes the strength of the source. Once again, the field presents a spherical symmetry for  $\theta = 0$ . The "correction" on the axis of the disk is a second-order quantity.

iv) *Fresnel's approximation: integral expression of "p" at the second order of  $r_0/r$*

Along the  $\bar{Oz}$  axis, the expression of  $p_\ell$  and  $p_d$  of the pressure at the second order of each system (respectively "column" and disk) are given by the general expression

$$p = i \frac{k_0 r_0 c_0}{2\pi} \frac{e^{-ikr}}{r} v \iint_{(D_0)} e^{-ik \frac{r_0^2}{2r}} dS_0, \quad (6.166)$$

where  $|\bar{r} - \bar{r}_0|$ , for  $\hat{x} = \hat{y} = 0$ , is replaced by  $(r + r_0^2/2r)$ .

For the "column", equation (6.166) yields

$$p = i \frac{k_0 \rho_0 c_0}{2\pi} \frac{e^{-ikr}}{r} (v \ell \delta y_0) \frac{1}{\ell} \int_{-\ell/2}^{+\ell/2} e^{-i \frac{k}{2r} x_0^2} dx_0,$$

or, denoting  $t^2 = \frac{k}{\pi r} x_0^2 \approx \frac{2}{\lambda r} x_0^2$  and  $u = \frac{\ell^2}{\lambda r}$ ,

$$p = i \frac{k_0 \rho_0 c_0}{2\pi} \frac{e^{-ikr}}{r} Q \frac{1}{\sqrt{2u}} \int_{-\sqrt{u/2}}^{\sqrt{u/2}} e^{-i \frac{\pi}{2} t^2} dt. \quad (6.167)$$

By definition, this integral is expressed as a combination of Fresnel's integrals, and the acoustic pressure field is

$$p = p_0 \sqrt{\frac{2}{u}} \left[ \mathbf{e} \left( \sqrt{\frac{u}{2}} \right) - i \mathcal{S} \left( \sqrt{\frac{u}{2}} \right) \right], \quad (6.168)$$

where  $p_0$  denotes the associated spherical field (6.163).

For the disk, equation (6.166) yields

$$p = i k_0 \rho_0 c_0 Q \frac{e^{-ikr}}{2\pi r} \frac{1}{\pi a^2} \int_0^{2\pi} d\phi_0 \int_0^a r_0 dr_0 e^{ik \frac{r_0^2}{2r}}, \quad (6.169)$$

or, denoting  $t = r_0^2$ ,

$$p = ik_0 \rho_0 c_0 Q \frac{e^{-ikr}}{2\pi r} \frac{2}{a^2} \frac{1}{2} \int_0^{a^2} e^{\frac{-ik}{2r} t} dt,$$

and, writing  $u = \frac{4a^2}{r\lambda}$ ,

$$p = p_0 \frac{\sin\left(\frac{\pi}{8} u\right)}{\frac{\pi}{8} u}, \quad (6.170)$$

where  $p_0$  denotes the associated spherical field (6.163).

v) *Appendix on Fresnel's integrals*

These integrals are defined by

$$\mathcal{E}(w) = \int_0^w \cos\left(\frac{\pi}{2} \tau^2\right) d\tau \quad \text{and} \quad \mathcal{S}(w) = \int_0^w \sin\left(\frac{\pi}{2} \tau^2\right) d\tau. \quad (6.171)$$

Some of their properties are

$$\mathcal{E}(0) = \mathcal{S}(0) = 0, \quad \mathcal{E}(-w) = -\mathcal{E}(w) \quad \text{and} \quad \mathcal{S}(-w) = -\mathcal{S}(w). \quad (6.172)$$

Moreover, in the  $(\mathcal{S}, \mathcal{E})$  plane, the square of the length of an element is written

$$\begin{aligned} d\ell^2 &= d\mathcal{E}^2 + d\mathcal{S}^2 = \left[ \left( \frac{d\mathcal{E}}{dw} \right)^2 + \left( \frac{d\mathcal{S}}{dw} \right)^2 \right] (dw)^2 \\ &= \left[ \cos^2\left(\frac{\pi}{2} w^2\right) + \sin^2\left(\frac{\pi}{2} w^2\right) \right] (dw)^2 \end{aligned} \quad \text{or} \quad d\ell^2 = dw^2, \quad (6.173)$$

and the slope of the curve at the point  $w$  is equal to

$$\operatorname{tg} \theta = \frac{d\mathcal{S}}{d\mathcal{E}} = \frac{\frac{d\mathcal{S}}{dw}}{\frac{d\mathcal{E}}{dw}} = \frac{\sin\left(\frac{\pi}{2} w^2\right)}{\cos\left(\frac{\pi}{2} w^2\right)} = \operatorname{tg}\left(\frac{\pi}{2} w^2\right),$$

$$\text{or } \theta = \frac{\pi}{2} w^2. \quad (6.174)$$



These properties are used to draw the curve, point by point, in Figure 6.14, which is called “Cornu’s spiral”, and to calculate Fresnel’s integrals.

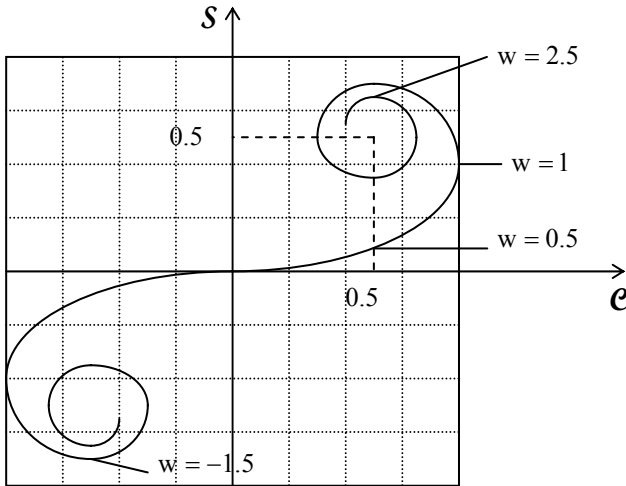

**Figure 6.14.** *Cornu’s spiral*

The spiral highlights the following properties of Fresnel’s integrals:

$$\begin{aligned}
 \mathcal{C}(\pm\infty) &= \mathcal{S}(\pm\infty) = \pm 1/2, \\
 \mathcal{C}(w > 4) &\approx \mathcal{C}(\infty), & \mathcal{C}(w < -4) &\approx \mathcal{C}(-\infty), \\
 \mathcal{S}(w > 4) &\approx \mathcal{S}(\infty), & \mathcal{S}(w < -4) &\approx \mathcal{S}(-\infty).
 \end{aligned}
 \tag{6.175}$$

6.3.2.6. *Modal approach for the acoustic field in a cavity with non-separable geometry*

The acoustics field in a cavity (domain  $D$ ) with a non-separable geometry cannot be directly derived using the modal theory (the eigenfunctions can only be evaluated numerically). By defining a domain ( $D_0$ ), containing ( $D$ ) and as close to ( $D$ ) as possible, in which the eigenfunctions satisfying Neumann’s conditions (for example) are known, it is possible to find the solution to the problem in ( $D$ ) as an expansion in the basis of eigenfunctions of ( $D_0$ ). The domain ( $D_0$ ) is such that it is compatible with the coordinate system used.

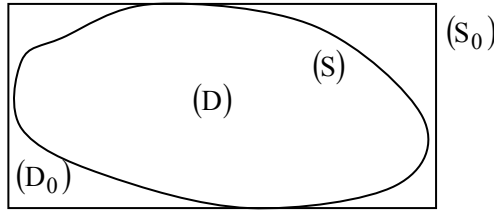

**Figure 6.15.** Considered domains

In the frequency domain, the problem can be written as

$$(\Delta + k^2)p(\vec{r}) = -f(\vec{r}), \quad \vec{r} \in D, \quad (6.176a)$$

$$\left( \frac{\partial}{\partial n} + ik\beta \right) p(\vec{r}) = 0, \quad \vec{r} \in S, \quad (6.176b)$$

where the factor  $f(\vec{r})$  denotes the effect of the sources and where  $\beta$  denotes the specific admittance of the walls  $(S)$  of the domain  $(D)$ .

The acoustics pressure field is a solution to the following system of integral equations (6.63), for any  $\vec{r} \in (S)$ :

$$\left. \begin{array}{l} \vec{r} \in D, \\ \vec{r} \in (D_0 - D), \end{array} \right\} p(\vec{r}) = \iiint_{(D)} G(\vec{r}, \vec{r}') f(\vec{r}') d\vec{r}' + \iint_{(S)} \left[ G(\vec{r}, \vec{r}') \frac{\partial}{\partial n'} p(\vec{r}') - p(\vec{r}') \frac{\partial}{\partial n'} G(\vec{r}, \vec{r}') \right] d\vec{r}'. \quad (6.177)$$

The Green's function satisfies Neumann's boundary conditions over the surface  $(S_0)$ . It is written as an expansion in the basis of eigenfunctions  $\varphi_p$  (6.20):

$$G(\vec{r}, \vec{r}') = \sum_p \frac{\varphi_p(\vec{r}')}{k_p^2 - k^2} \varphi_p(\vec{r}), \quad (6.178)$$

the eigenfunctions being solutions to the following eigenvalue problem:

$$(\Delta + k_p^2) \varphi_p(\vec{r}) = 0, \quad \vec{r} \in (D_0), \quad (6.179)$$

$$\frac{\partial}{\partial n} \varphi_p(\vec{r}) = 0, \quad \vec{r} \in (S_0). \quad (6.180)$$

The matrix equation, the solutions to which give the expansion coefficients of the sought solution  $p$  in the basis  $\varphi_p$ :

$$p(\vec{r}) = \sum_q a_q \varphi_q(\vec{r}), \tag{6.181}$$

is obtained by substituting equations (6.181) and (6.178) into equation (6.177):

$$\left. \begin{array}{l} \vec{r} \in (D), \\ \vec{r} \in (D_0 - D), \end{array} \right\} \sum_q a_q \varphi_q(\vec{r}) \left\{ = \sum_q \left[ \frac{F_q}{k_q^2 - k^2} - \sum_p \frac{a_p}{k_q^2 - k^2} (E_{qp} + A_{qp}) \right] \varphi_q(\vec{r}), \tag{6.182}$$

where  $F_q = \iiint_{(D)} \varphi_q(\vec{r}') f(\vec{r}') d\vec{r}'$ ,  $E_{qp} = \iint_{(S)} \varphi_q(\vec{r}') ik \beta \varphi_p(\vec{r}') d\vec{r}'$ ,

and  $A_{qp} = \iint_{(S)} \varphi_p(\vec{r}') \frac{\partial}{\partial n'} \varphi_q(\vec{r}') d\vec{r}'$ .

The matrix equation, by projection over an element of the basis  $\varphi_m$  and by considering the property of orthogonality of the eigenfunctions  $\varphi_p$  on  $(D_0)$ , becomes

$$\sum_q a_q N_{mq} = \frac{F_m}{k_m^2 - k^2} - \frac{1}{k_m^2 - k^2} \sum_p a_p (E_{mp} + A_{mp}), \tag{6.183}$$

with  $N_{mq} = \iiint_{(D)} \varphi_m(\vec{r}) \varphi_q(\vec{r}) d\vec{r}$ .

Equation (6.183) can be written as

$$\sum_q (D_{mq} + E_{mq} + A_{mq}) a_q = F_m, \tag{6.184}$$

where  $D_{mq} = N_{mq} (k_m^2 - k^2)$ ,

or in a matrix form as

$$[(\mathbf{D}) + (\mathbf{E}) + (\mathbf{A})] (\mathbf{a}) = (\mathbf{F}). \tag{6.185}$$

Note: the solution to the eigenvalue problem associated with the problem (6.176),

$$(\Delta + \chi_m^2) \psi_m(\vec{r}) = 0, \quad \vec{r} \in (D), \quad (6.186a)$$

$$\left( \frac{\partial}{\partial n} + ik\beta \right) \psi_m(\vec{r}) = 0, \quad \vec{r} \in (S), \quad (6.186b)$$

can similarly be obtained, replacing  $p(\vec{r})$  by  $\psi_m(\vec{r})$  in equation (6.177) before proceeding as above. In the particular case where  $\beta = 0$  (Neumann's eigenvalue problem), the expansion coefficients  $(C_m)_q$  of  $\psi_m$  on the basis of eigenfunctions  $\varphi_q$ ,

$$\psi_m(\vec{r}) = \sum_q (C_m)_q \varphi_q(\vec{r}), \quad (6.187)$$

and the associated eigenvalues  $\chi_m$  are solutions to the following matrix eigenvalues problem:

$$[\mathbf{M}](\mathbf{C}_m) = \chi_m^2 [\mathbf{N}](\mathbf{C}_m), \quad (6.188)$$

where  $[\mathbf{M}]$  is the matrix of components  $M_{qp} = k_q^2 N_{qp} + A_{qp}$ , the matrices  $\mathbf{N}$  and  $\mathbf{A}$  being defined by equations (6.182) and (6.183).

### 6.3.2.7. Radiation from a cylindrical waveguide: length correction

An incident harmonic plane wave is propagating (wave created in the positive  $z$ -direction) in a semi-infinite cylindrical cavity with a circular cross-section and rigid walls along the axis  $Oz$ . At the position  $z = 0$ , the cavity ends in a rigid infinite screen (Figure 6.16). The propagating wave generates, at  $z = 0$ , a reflected wave and a radiated wave in the semi-infinite plane  $z > 0$ .

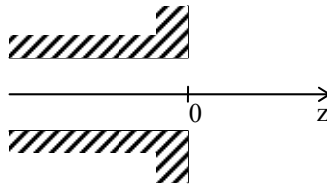

**Figure 6.16.** Wave guide ending as an infinite rigid plane

According to the results of section 4.3.1, the acoustics field in a guide can be written as

$$p_- = A \left( e^{-ikz} + R e^{ikz} \right) e^{i\omega t}, \quad (6.189)$$

where  $R$  denotes the reflection coefficient, and the field radiated  $p_+$  is assumed close to that from a plane piston in a rigid infinite screen, taken as Rayleigh's solution (6.146). Since the radiated field in a tube, radiating source at  $z=0$ , is a field of plane waves, the particle velocity is independent of the coordinates  $(x, y)$  of the section of the guide considered. Consequently, in Rayleigh's integral, the velocity  $v)_{z=0}$  is a constant equal (according to equation (6.189)) to

$$v)_{z=0} = A \frac{1-R}{\rho_0 c_0}. \quad (6.190)$$

This result guarantees the continuity of the velocity at the interface  $z=0$ . One still needs to consider the continuity of the pressure ( $p_- = p_+$  at  $z=0$ ) or the continuity of the impedances ( $Z_- = Z_+$  at  $z=0$ ). Both expressions are equivalent since the particle velocity is also continuous. Considering equations (6.189) and (6.190) on one hand, and considering the equation giving the (mechanical) radiation impedance of Rayleigh at low frequencies ( $k_0 a \ll 1$ ) on the other hand,

$$Z_- = \rho_0 c_0 \frac{1+R}{1-R} \quad \text{and} \quad Z_+ = i \rho_0 c_0 \frac{8k_0 a}{3\pi}, \quad (6.191)$$

one obtains:

$$\frac{1+R}{1-R} \approx i \frac{8k_0 a}{3\pi}, \quad (6.192)$$

or, more generally, replacing the factor  $(\pi a^2)$  by the surface  $S$  for a cylindrical tube which section is not necessarily circular,

$$\frac{1+R}{1-R} \approx i \frac{8k_0 \sqrt{S}}{3\pi^{3/2}}. \quad (6.193)$$

Since the second term of equation (6.192) is assumed smaller than one, one can expand the expression of  $R$  to the first order:

$$R \approx -1 + i \frac{16k_0 a}{3\pi}; \quad (6.194)$$

it is a complex number of the form

$$R = R_M [\cos(\pi\sigma) + i \sin(\pi\sigma)], \quad (6.195)$$

where  $\sigma = -1 - \frac{16k_0a}{3\pi^2}$  and  $R_M = 1$ .

The coordinate of the first minimum of the stationary wave is given, according to equation (4.61), by

$$z_m = -(1 + \sigma)\lambda / 4, \quad (6.196)$$

$$= 8a / (3\pi). \quad (6.197)$$

If the radiation impedance is ignored ( $Z_+ = 0$ ), meaning if  $p_+ = 0$  at  $z = 0$ , then the position of the first minimum would be given by  $z_m = 0$ . Equation (6.197) shows that the system of stationary waves is translated of a length

$$\Delta\ell = \frac{8a}{3\pi} = \frac{8\sqrt{S}}{3\pi^{3/2}}, \text{ with } S = \pi a^2, \quad (6.198)$$

in the direction of the increasing coordinate  $z$  (Figure 6.16) when the radiation impedance is considered. In other words, when the reaction due to the radiation is not neglected, the system of stationary waves is the one obtained for a longer tube (by  $\Delta\ell$ ) at the extremity of which the radiation impedance would be assumed equal to zero ( $p = 0$  at  $z = \Delta\ell$ ). The length  $\Delta\ell$  is therefore called the “length correction”.

The substitution of equation (6.198) into the expression of  $Z_+$  (6.191) gives

$$Z_+ = i\rho_0c_0 k_0 \Delta\ell. \quad (6.199)$$

This result holds as long as  $k_0\Delta\ell \ll 1$  and is acceptable as a first approximation even in absence of rigid screen. It is applicable to cases of “strong” geometrical discontinuities in the tube.

Note: the inequality  $k_0a \ll 1$  used to obtain the approximations of the radiation impedance implies plane wave geometry for the acoustic perturbation in the tube. The cut-off of the first mode after the plane mode occurs for  $k_0a = \gamma_{10} = 1.84$ .

Moreover, the length correction  $\Delta\ell$ , within the domain of validity of the present calculation, is, at most, equal to 5% of the wavelength since (very approximately):

$$\frac{\Delta\ell}{\lambda} = \frac{\Delta\ell k_0}{2\pi} = \frac{8k_0a}{6\pi^2} < 0.05.$$

6.3.2.8. Helmholtz resonator

6.3.2.8.1. Preliminary: acoustics field in opened cavity with parallel walls

A cylindrical cavity of volume  $V$ , with perfectly reflecting walls, has two parallel walls perpendicular to the  $O\bar{z}$  axis. One of these walls has an aperture of surface  $S$  which is small compared to the surface  $S_L$  of the wall. Also, the dimensions remain very small compared to the considered wavelength, thus  $\sqrt{S} \ll \sqrt[3]{V} \ll \lambda$ .

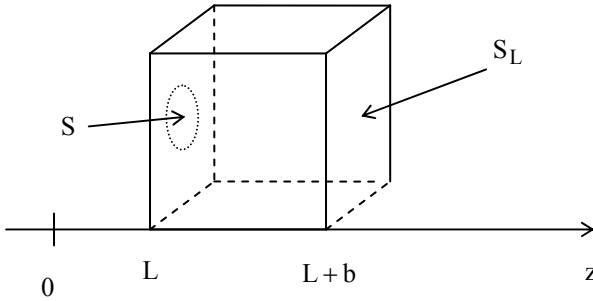

Figure 6.17. Cavity with small aperture of surface  $S$

In harmonic regimes, the complex amplitude of the acoustics pressure in the cavity can be expanded in the basis of transverse normal modes (coordinates  $\vec{w}$ ) as follows:

$$p = \rho_0 c_0 \sum_m \left[ a_m e^{-ik_{zm}(z-L)} + b_m e^{ik_{zm}(z-L)} \right] \Psi_m(k_{wm} \vec{w}), \tag{6.200}$$

where  $m$  denotes a couple of indexes,

with  $k_{zm}^2 = k_0^2 - k_{wm}^2$ ,  $k_{wm}$  denoting the eigenvalues associated to the orthogonal eigenfunctions  $\Psi_m(k_{wm} \vec{w})$ .

The particle velocity in the  $O\bar{z}$  direction takes the following form:

$$v_z = \frac{i}{k_0 \rho_0 c_0} \frac{\partial p}{\partial z} = \sum_m \frac{k_{zm}}{k_0} \left[ a_m e^{-ik_{zm}(z-L)} - b_m e^{ik_{zm}(z-L)} \right] \Psi_m(k_{wm} \vec{w}), \tag{6.201}$$

and the orthogonality property of the eigenfunctions  $\Psi_m$  leads to

$$\iint_{S_L} \Psi_q(k_{wq} \vec{w}) v_z dS = \sum_m \frac{k_{zm}}{k_0} \left[ a_m e^{-ik_{zm}(z-L)} - b_m e^{ik_{zm}(z-L)} \right] \delta_{mq} .$$

Thus, at  $z = L$  considering that the velocity  $v_z(L)$  is null outside the surface  $S$ ,

$$a_m - b_m = \frac{k_0}{k_{zm}} \bar{v}_z \bar{\Psi}_m S, \quad (6.202)$$

where the velocity  $v_z$  has been replaced by its mean value  $\bar{v}_z$  calculated over the surface of the aperture  $S$  and where  $\bar{\Psi}_m = \frac{1}{S} \iint_S \Psi_m dS$  is the mean value of  $\Psi_m$  over the same surface.

Moreover, the  $z$  component of the particle velocity being null at  $z = L + b$ , equation (6.201) leads to

$$\begin{aligned} a_m e^{-ik_{zm}b} &= b_m e^{ik_{zm}b}, \\ \text{or } a_m + b_m &= -i \cotg(k_{zm}b)(a_m - b_m). \end{aligned} \quad (6.203)$$

Thus, the substitution of equation (6.202) into the above equation gives

$$a_m + b_m = -i \frac{k_0}{k_{zm}} \cotg(k_{zm}b) \bar{v}_z \bar{\Psi}_m S. \quad (6.204)$$

The mean value of the acoustic pressure in the aperture, denoted

$$p(L) = \frac{1}{S} \iint_S p(x=L) dS,$$

takes, according to equations (6.200) and (6.204), the following form:

$$p(L) = -i \rho_0 c_0 S \bar{v}_z \sum_m \frac{k_0}{k_{zm}} \cotg(k_{zm}b) \bar{\Psi}_m^2. \quad (6.205a)$$

Therefore, by isolating the first term of the series ( $m = 0$ ) from the others, the acoustic impedance of the aperture is written as ( $k_0 = k_{z0}$  since  $k_{w0} = 0$ )

$$\frac{1}{\rho_0 c_0} \frac{p(L)}{\bar{v}_z} = \frac{Z_L}{\rho_0 c_0} = -i S \cotg(k_0 b) \bar{\Psi}_0^{-2} + i k_0 \delta, \quad (6.205b)$$

or, since  $\Psi_0 = 1/\sqrt{S_L}$  and  $k_{zm} \approx -ik_{wm}$  for  $m \neq 0$ , as



$$\frac{Z_L}{\rho_0 c_0} = -i \frac{S}{S_L} \cotg(k_0 b) + i k_0 \delta, \quad (6.206)$$

$$\text{with } \delta = -i S \sum_m \frac{1}{k_{wm}} \cotg(-i k_{wm} b) \bar{\Psi}_m^{-2}. \quad (6.207)$$

The first term of equation (6.206) can successively be written, since  $k_0 b \ll 1$ , as

$$-i \frac{S}{S_L} \cotg(k_0 b) = \frac{S}{S_L} \frac{1}{i k_0 b} = \frac{S}{V} \frac{1}{i k_0}, \quad (6.208)$$

and in the expression of  $\delta$ , since  $k_{wm} b \gg 1$ ,

$$-i \cotg(-i k_{wm} b) \approx 1.$$

Consequently, equation (6.505b) gives

$$p(L) = \rho_0 c_0^2 \frac{S}{V} \frac{\bar{v}_z}{i \omega} + \rho_0 c_0 \bar{v}_z i k_0 \delta, \quad (6.209)$$

$$\text{or } p(L) = -\rho_0 c_0^2 \frac{\delta V}{V} + \rho_0 c_0 \bar{v}_z i k_0, \quad (6.210)$$

$$\text{with } \delta = S \sum_m \frac{\bar{\Psi}_m^{-2}}{k_{wm}}.$$

The first term on the right-hand side of equation (6.210) denotes the uniform field of a cavity in absence of dissipation (compare with section 3.73). The more delicate interpretation of the second term is presented here in the case where the section of the cavity and the aperture are squares of respective width  $a$  and  $a_0$ , the aperture being at the centre of the wall  $z = L$ . Thus

$$\bar{\Psi}_m = \frac{\sqrt{2 - \delta_{\mu 0}}}{\sqrt{a}} \frac{\sqrt{2 - \delta_{\nu 0}}}{\sqrt{a}} \cos\left(\frac{\mu \pi}{a} x\right) \cos\left(\frac{\nu \pi}{a} y\right), \quad (6.211)$$

$\mu$  and  $\nu$  being integers,

$$k_{wm}^2 = \frac{\mu^2 \pi^2}{a^2} + \frac{\nu^2 \pi^2}{a^2},$$

and  $\delta$  becomes

$$\delta = \frac{a_0^2}{a} \sum_{\substack{(\mu, \nu) \neq (0,0) \\ \text{even}}} \frac{(2-\delta_{\mu 0})(2-\delta_{\nu 0})}{\pi \sqrt{\mu^2 + \nu^2}} \left[ \frac{1}{a^2} \int_{(a-a_0)/2}^{(a+a_0)/2} \cos\left(\frac{\mu \pi x}{a}\right) dx \int_{(a-a_0)/2}^{(a+a_0)/2} \cos\left(\frac{\nu \pi y}{a}\right) dy \right]^2,$$

thus

$$\delta = \frac{a_0^2}{a} \sum_{\substack{(\mu, \nu) \neq (0,0) \\ \text{even}}} \frac{(2-\delta_{\mu 0})(2-\delta_{\nu 0})}{\pi \sqrt{\mu^2 + \nu^2}} \left[ (-)^{(\mu+\nu)/2} \frac{\sin(\mu \pi a_0 / 2a)}{\mu \pi a_0 / 2a} \frac{\sin(\nu \pi a_0 / 2a)}{\nu \pi a_0 / 2a} \right]^2 \text{ or}$$

$$\delta = \frac{a_0^2}{a} \sum_{(m,n) \neq (0,0)} \frac{(2-\delta_{m0})(2-\delta_{n0})}{2\pi \sqrt{m^2 + n^2}} \left[ \frac{\sin(m \pi a_0 / a)}{m \pi a_0 / a} \right]^2 \left[ \frac{\sin(n \pi a_0 / a)}{n \pi a_0 / a} \right]^2. \quad (6.212)$$

By denoting  $x = m \pi a_0 / a$  and  $y = n \pi a_0 / a$ :

$$\delta = \frac{2\sqrt{S}}{\pi^2} \left[ \sum_{\substack{m=1, \infty \\ n=1, \infty}} \frac{(\pi a_0 / a)^2}{\sqrt{x^2 + y^2}} \left( \frac{\sin x \sin y}{x y} \right)^2 + \sum_{m=1}^{\infty} \frac{(\pi a_0 / a)^2}{x} \left( \frac{\sin x}{x} \right)^2 \right], \quad (6.213)$$

and since the slope in  $\pi a_0 / a$  of  $x$  and  $y$  in the sums remains small, these sums can be transformed into integrals. Consequently, the factor  $\delta$  becomes

$$\delta = \frac{2\sqrt{S}}{\pi^2} \left[ \int_0^{\infty} \int_0^{\infty} \frac{dx dy}{\sqrt{x^2 + y^2}} \left( \frac{\sin x \sin y}{x y} \right)^2 + \frac{\pi a_0}{a} \int_0^{\infty} \frac{\sin^2 x}{x^3} dx \right],$$

and the calculation of the integrals (using polar coordinates for the first integral) leads to the following result:

$$\delta \approx 0.48 \sqrt{S} \left( 1 - 1.25 \frac{a_0}{a} \right) \approx \frac{\sqrt{S}}{2}. \quad (6.214)$$

The expression (6.214) of  $\delta$  is very close to  $\frac{8\sqrt{S}}{3\pi^{3/2}}$  that is nothing other than the factor  $\frac{8a}{3\pi}$  of equation (6.151). In other words, the factor  $(i\rho_0 c_0 k_0 \delta)$  of equation (6.210) is, as a first approximation, Rayleigh's radiation impedance  $Z_0$  (6.151):

$$i\rho_0 c_0 k_0 \delta \approx \frac{Z_0}{S}. \quad (6.215)$$

In conclusion, the expression (6.210) of the pressure  $p(L)$  at the aperture is the sum of the pressure associated with the variation of volume  $\delta V$  of the cavity

$$-\rho_0 c_0^2 \frac{\delta V}{V},$$

to which one needs to superpose the effect of the discontinuity at the aperture that, as a first approximation, can be introduced by Rayleigh's pressure factor

$$i\rho_0 c_0 k_0 \delta \bar{v}_z \approx \frac{Z_0}{S} \bar{v}_z. \quad (6.216)$$

Henceforth, the dissipation is introduced by completing each of these factors using the results obtained in the sections on small cavities (equation (3.73)) and those concerning the radiation from a disk in a screen (equation (6.151)).

#### 6.3.2.8.2. Helmholtz resonator: basic model

The Helmholtz resonator (Figure 6.18) is a system composed of a volume linked to the exterior medium by a relatively thin and short tube opening on a finite or infinite screen, set in oscillation under the effect of an exterior source, and eventually reacting on the radiation of this source (possible amplification), absorbing the sound energy and redistributing it continuously in all directions (diffusion), dissipating part of the energy especially if an absorbing materials perturbs the oscillation within the resonator (dissipation) and, finally, releases the stored energy after extinction of the source until the end of the reverberation. All these effects are optimums at the vicinity of the resonance frequency of the resonator.

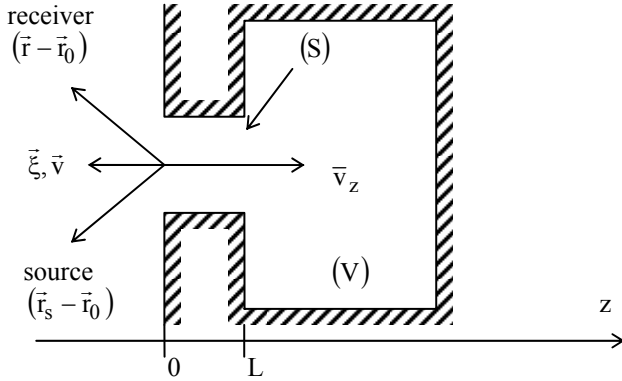

**Figure 6.18.** Helmholtz resonator  
(the coordinate of the aperture of the resonator is denoted  $\vec{r}_0$ )

The device is such that the following hypotheses can be made: the section  $S$  of the tube is very small compared to the surface of the walls of the cavity (of volume  $V$ ) and the dimensions of the resonator (among which is the length of the tube  $L$ ) are very small compared to the wavelength  $\lambda$  considered (that corresponds to the resonance frequency of the whole system). This can be written as

$$\sqrt{S} \ll \sqrt[3]{V} \ll \lambda \quad \text{and} \quad L \ll \lambda \quad (6.217)$$

(the length of the tube can be equal to zero). Also, the geometry of the surface  $S$ , as that of the volume  $V$ , is not relevant if it remains reasonably regular.

The considered space is divided into three regions: the semi-infinite space  $z < 0$ , the tube  $z \in [0, L]$ , and the volume  $V$  of the resonator. The properties of the acoustic field are expressed, one after the other in each domain and at the boundaries. The acoustic source located at  $\vec{r}_s$  is assumed monopolar and harmonic with total source strength  $Q_s$ .

i) *The acoustic field in the semi-infinite domain ( $z < 0$ )*

The complex amplitude of the acoustic field in the semi-infinite domain ( $z < 0$ ) is given by the integral equation (6.63)

$$\begin{aligned} p(\vec{r}) = & \iiint i k_0 \rho_0 c_0 Q_s \delta(\vec{r}_0 - \vec{r}_s) G(\vec{r}, \vec{r}_0) dV_0 \\ & + \iint_{(S)} G(\vec{r}, \vec{r}_0) \frac{\partial p(\vec{r}_0)}{\partial n_0} dS_0 \end{aligned} \quad (6.218)$$

as long as the chosen Green's function satisfies Neumann's condition at the surface  $z = 0$  (6.8):

$$G(\vec{r}, \vec{r}_0) = \frac{e^{-ik_0|\vec{r}-\vec{r}_0|}}{4\pi|\vec{r}-\vec{r}_0|} + \frac{e^{-ik_0|\vec{r}-\vec{r}'_0|}}{4\pi|\vec{r}-\vec{r}'_0|}, \tag{6.219}$$

where  $\vec{r}'_0$  is the symmetrical image of  $\vec{r}_0$  with respect to the plane  $z = 0$ .

Considering the hypotheses made (punctual source and very small aperture  $S$ ), equation (6.218) becomes

$$p(\vec{r}) = p_i(\vec{r}) + p_r(\vec{r}) + p'_r(\vec{r}) \tag{6.220}$$

$$\text{with } p_i(\vec{r}) + p_r(\vec{r}) = ik_0 \rho_0 c_0 Q_s G(\vec{r}, \vec{r}_s), \tag{6.221}$$

$$\text{and } p'_r(\vec{r}) = ik_0 \rho_0 c_0 v S G(\vec{r}, \vec{r}_0), \tag{6.222}$$

where  $v = -\bar{v}_z$  is the mean velocity at the aperture and where  $\vec{r}_0$  denotes the position of the aperture.

Equations (6.220), (6.221) and (6.222) show that the field is the sum of a direct field emitted by the real source, a field emitted by the image source (with respect to the plane  $z = 0$ ) and a field radiated by the motion of the aperture (assumed uniform) that, at great distance (great values of  $r$ ), is of the form (equation (6.147))

$$p'_r(\infty) \approx ik_0 \rho_0 c_0 v S \frac{e^{-ik_0|\vec{r}-\vec{r}_0|}}{2\pi|\vec{r}-\vec{r}_0|} \frac{2J_1\left[k_0\sqrt{S/\pi} \sin \theta\right]}{k_0\sqrt{S/\pi} \sin \theta}. \tag{6.223}$$

Considering the expression (6.151) of Rayleigh's radiation impedance, the pressure field at the aperture ( $\vec{r}_0 = \vec{r}'_0$ ), denoted  $p(0)$ , becomes

$$p(0) = 2P_0 + Z_e v, \tag{6.224}$$

$$\text{with } P_0 = p_i(\vec{r}_0) = p_r(\vec{r}_0), \tag{6.225}$$

$$\text{and } Z_e = \rho_0 c_0 (R_0 + ik_0 \delta) \text{ where } R_0 = \frac{k_0^2 S}{2\pi} \text{ and } \delta = \frac{8\sqrt{S}}{3\pi^{3/2}}. \tag{6.226}$$

ii) *Expression of the acoustic field at the aperture ( $z = L$ )*

According to the previous paragraph, the acoustic pressure  $p(L)$  is the sum of the pressure in the cavity (which has small dimensions compared to the wavelength

considered) and the “Rayleigh’s pressure” at the vicinity of a small vibrating surface in a screen (equation (6.151)):

$$p(L) = \frac{-\rho_0 c_0^2 (S/V) \xi}{1 + \frac{\gamma S_c / V}{i\omega \chi_T \bar{Z}_p}} - \left[ \rho_0 c_0 \frac{k_0^2 S}{2\pi} (i\omega \xi) + \rho_0 \frac{8\sqrt{S}}{3\pi^{3/2}} (-\omega^2 \xi) \right], \quad (6.227)$$

where  $\xi$  denotes the displacement at the aperture ( $i\omega \xi = v$ ) and where  $S_c$  denotes here the surface of the cavity wall.

In this expression  $\bar{Z}_p$  denotes the mean impedance of the wall that, if the walls are perfectly rigid, includes the effects of the thermal boundary layers leading, according to the arguments given after equation (6.132), to

$$\frac{\gamma S_c / V}{i\omega \chi_T \bar{Z}_p} = \frac{1-i}{\sqrt{2}} (\gamma-1) \frac{S_c}{V} \sqrt{\frac{c_0 \ell_h}{\omega}}. \quad (6.228)$$

Equation (6.227) can be written after a Taylor’s development at the first order of the quantity given by equation (6.228) that is assumed much smaller than the unit, as

$$p(L) = -\rho_0 c_0 v \left[ \frac{S/V}{ik_0} + R_L + ik_0 \delta \right], \quad (6.229)$$

$$\text{with } R_L = \frac{S}{V} \frac{1}{k_0} \operatorname{Re} \left( \frac{\gamma S_c / V}{i\omega \chi_T \bar{Z}_p} \right) + \frac{k_0^2 S}{2\pi}. \quad (6.230)$$

### iii) Expression of the acoustics field in the tube of length $L$

The substitution of equation (3.156) into equation (3.158) leads to

$$p(L) - p(0) \approx \rho_0 L (-\omega^2 \xi) + \rho_0 c_0 L \sqrt{\frac{2\pi k_0 \ell'_v}{S}} (i\omega \xi), \quad (6.231)$$

$$\text{or } p(L) - p(0) \approx \rho_0 c_0 v (\Gamma L + ik_0 L), \quad (6.232)$$

$$\text{with } \Gamma = \sqrt{\frac{2\pi k_0 \ell'_v}{S}}. \quad (6.233)$$

iv) *Helmholtz resonator equations*

The set of three equations (6.224), (6.229), and (6.232) define the problem being considered. This formalism is presented in three different, but equivalent, forms (6.234a), (6.235a) and (6.235b).

The substitution of equation (6.229) into (6.232) leads to

$$p(0) = -\rho_0 c_0 v \left[ ik_0(L + \delta) + (R_L + \Gamma L) + \frac{S/V}{ik_0} \right], \tag{6.234a}$$

that, associated with (6.224) and (6.226),

$$p(0) = 2P_0 + \rho_0 c_0 (R_0 + ik_0 \delta) v, \tag{6.234b}$$

gives

$$\rho_0 c_0 \left[ ik_0(L + 2\delta) + (R_0 + R_L + \Gamma L) + \frac{S/V}{ik_0} \right] v = -2P_0 \tag{6.235a}$$

or

$$\rho_0(L + 2\delta)(-\omega^2 \xi) + \rho_0 c_0 (R_0 + R_L + \Gamma L)(i\omega \xi) + \rho_0 c_0^2 \frac{S}{V} \xi = -2P_0. \tag{6.235b}$$

where

$\delta = \frac{8\sqrt{S}}{3\pi^{3/2}}$  denotes the “length correction”,

$R_0 = \frac{k_0^2 S}{2\pi}$  denotes the radiation resistance at  $z = 0$ ,

$R_L = \frac{k_0^2 S}{2\pi} + \frac{S}{V} \frac{1}{k_0} \operatorname{Re} \left( \frac{\gamma S_c / V}{ik_0 c_0 \chi_T \bar{Z}_p} \right)$  is the sum of

the radiation resistance at the discontinuity,

$z = L$  and the factor of resistance associated with the wall impedance of the cavity,

$\Gamma = \sqrt{\frac{2\pi k_0 \ell'_v}{S}}$  is the dissipation factor at the walls of the tube.

## 6.3.2.8.3. Properties of the resonator

i) *Resonance frequency of the resonator*

By ignoring the dissipative factor, and after extinction of the source, the inverse Fourier transform of equation (6.235b) is reduced to

$$\rho_0(L + 2\delta) \frac{\partial^2 \xi}{\partial t^2} + \rho_0 c_0^2 \frac{S}{V} \xi = 0. \quad (6.236)$$

The oscillator is described by an equation in the form

$$M \frac{\partial^2 \xi}{\partial t^2} + K \xi = 0.$$

Its eigenfrequency is written as

$$N_r = \frac{1}{2\pi} \sqrt{\frac{K}{M}} = \frac{c_0}{2\pi} \sqrt{\frac{S/V}{L + 2\delta}}, \quad (6.237)$$

and if  $L \rightarrow 0$ :

$$N_r = \frac{c_0}{2\pi} \sqrt{\frac{S/V}{2\delta}}. \quad (6.238)$$

This result corresponds to a value of wavenumber  $k_r$  equal to

$$k_r = \sqrt{\frac{S/V}{L + 2\delta}}, \quad (6.239)$$

that will be taken, for the sake of simplicity, as the expression of  $k_0$  expressing the dissipative factor ( $R_0 + R_L + \Gamma L$ ). This approximation holds since the resonator is only used at the vicinity of this resonance frequency. Therefore, the dissipative factor ( $R_0 + R_L + \Gamma L$ ) is assumed independent of the frequency and will be denoted  $R$ .

ii) *The reverberation role of the resonator*

After extinction of the source, the Fourier transform of equation (6.235b) becomes



$$M \frac{\partial^2 \xi}{\partial t^2} + R \frac{\partial \xi}{\partial t} + K \xi = 0, \tag{6.240}$$

for which the solution, at the first order of the small factor  $R$ , is

$$\xi = \xi_0 e^{-\left(\frac{R}{2M} - i2\pi N_r\right)t}. \tag{6.241}$$

The motion of the fluid at the aperture ( $z=0$ ) generates a sound at the resonance frequency of the resonator with exponentially decreasing amplitude: the resonator acts as a reverberator.

The amplitude  $\xi_0$  at the extinction of the source is directly given by equation (6.235):

$$\xi_0 = \frac{2iP_0}{\rho_0 c_0^2 k_0} \frac{1}{ik_0(L + 2\delta) + (R_0 + R_L + \Gamma L) + \frac{S/V}{ik_0}}, \tag{6.242}$$

thus, at the resonance  $k_0 = k_r = \sqrt{\frac{S/V}{L + 2\delta}}$ , (6.239),

$$\xi_0 = \xi_0)_r = \frac{2iP_0}{\rho_0 c_0^2 k_0} \frac{1}{(R_0 + R_L + \Gamma L)}. \tag{6.243}$$

iii) *Diffusion role of the resonator*

The energy radiation which is induced by the acoustic oscillation at the aperture of the resonator exhibits a behavior that can be described by equation (6.223) of the asymptotic field due to the flow ( $vS$ ) at  $z = 0$ . This shows that part of the energy is radiated back in all directions following the asymptotic law

$$\frac{2J_1\left[k_0 \sqrt{S/\pi} \sin \theta\right]}{k_0 \sqrt{S/\pi} \sin \theta},$$

that constitutes a diffusion law.

iv) *Absorption of the resonator*

According to equation (6.234a), the acoustic power  $P_a$  absorbed by the resonator is

$$P_a = \frac{S}{4} [p(0)v^* + p^*(0)v] = \frac{S}{2} \rho_0 c_0 (R_L + \Gamma L) |v|^2, \quad (6.244)$$

or, if substituting the expression (6.235a) of  $v$ ,

$$P_a = \frac{S}{2} \rho_0 c_0 (R_L + \Gamma L) \frac{4|P_0|^2}{\rho_0^2 c_0^2} \frac{1}{(R_0 + R_L + \Gamma L)^2 + k_0^2 \left( L + 2\delta - \frac{S/V}{k_0^2} \right)^2}.$$

The power propagated by the incident acoustic wave for a same surface  $S$ , in the case of normal incidence, can be written as

$$P_i = \frac{S |P_0|^2}{2 \rho_0 c_0},$$

and the ratio of absorbed power to incident power is

$$\frac{P_a}{P_i} = \frac{4(R_L + \Gamma L)}{(R_0 + R_L + \Gamma L)^2 + k_0^2 \left( L + 2\delta - \frac{S/V}{k_0^2} \right)^2}. \quad (6.245)$$

This absorption coefficient is maximum at the resonance frequency ( $k_0 = k_r$ ) and is then

$$\left. \frac{P_a}{P_i} \right)_m = \frac{4(R_L + \Gamma L)}{(R_0 + R_L + \Gamma L)^2}. \quad (6.246)$$

The factor  $u = (R_L + \Gamma L)$  is governing the absorption of the resonator. The maximum of absorption, at the resonance frequency, can theoretically be obtained by acting on the constitution of the walls of the resonator to maximize the function of the variable  $u$

$$\left. \frac{P_a}{P_i} \right)_m = \frac{4u}{(u + R_0)^2},$$

which implies  $u = R_0$ , meaning  $R_L + \Gamma L = R_0$ . However, such condition is difficult to implement.

iv) *Amplification of the resonator*

The presence of a resonator in a domain modifies the characteristics of the domain, particularly the radiation impedance of the sources by reaction of the acoustic field on their surface and therefore modifies the acoustic energy emitted by these sources in the domain.

This can be verified by considering equations (6.220), (6.221) and (6.222) and introducing the effect of a unique source, quasi-punctual, of radius (a) and located at a short distance  $r = |\vec{r}_s - \vec{r}_0|$  from the aperture of the resonator. Written at any given point on the surface of the source, these equations lead to the expression of the pressure  $p_s$  at the surface of the source:

$$p_s = p_i + p_r + p_r' = ik_0\rho_0c_0 \left[ Q_s \left( \frac{e^{-ik_0a}}{4\pi a} + \frac{e^{-ik_0(2r)}}{4\pi(2r)} \right) + vS \frac{e^{-ik_0r}}{2\pi r} \right], \quad (6.247)$$

or, at the first order of the small quantities (a) and (r),

$$p_s = ik_0\rho_0c_0 \left[ Q_s \left( \frac{1 - ik_0a}{4\pi a} + \frac{1 - ik_0(2r)}{4\pi(2r)} \right) + vS \frac{1 - ik_0r}{2\pi r} \right]. \quad (6.248)$$

From here, the resonator is assumed without the screen at  $z = 0$  (Figure 6.19). In this case, the chosen Green's function is that which satisfied Sommerfeld's condition at infinity, which implies no image sources (and therefore no reflected field  $p_r$ ).

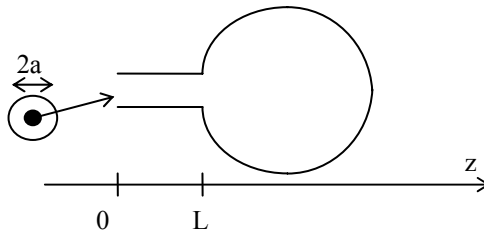

**Figure 6.19.** Helmholtz resonator without screen, punctual source at proximity

In such conditions, equation (6.248) becomes

$$p_s = ik_0 \rho_0 c_0 \left[ Q_s \frac{1 - ik_0 a}{4\pi a} + v S \frac{1 - ik_0 r}{4\pi r} \right]. \quad (6.249)$$

The unknown  $v$  can be expressed using equation (6.235a) at the resonance frequency

$$k_0^2 = k_r^2 = \frac{S/V}{L + 2\delta},$$

and replacing  $(2P_0)$  in the right-hand side term by  $P_0$  since there is no screen, leading to

$$\rho_0 c_0 (R_0 + R_L + \Gamma L) S v = -P_0 S, \quad (6.250)$$

where, applying Born's approximation, the amplitude  $P_0$  is assumed close to the incident field at the aperture, thus

$$P_0 \approx ik_0 \rho_0 c_0 Q_s \frac{1 - ik_0 r}{4\pi r}. \quad (6.251)$$

The substitution of equations (6.251) and (6.250) into equation (6.249) leads to the following expression of the pressure  $p_s$  at the source:

$$p_s = ik_0 \rho_0 c_0 \left[ Q_s \frac{1 - ik_0 a}{4\pi a} - \frac{ik_0 S Q_s}{R_0 + R_L + \Gamma L} \left( \frac{1 - ik_0 r}{4\pi r} \right)^2 \right]. \quad (6.252)$$

The total reaction force  $F_s$  exerted by the acoustic wave onto the surface of the source is written as

$$\begin{aligned} F_s &= 4\pi a^2 p_s, \\ &= \rho_0 c_0 Q_s k_0^2 a^2 \left[ 1 + \frac{S}{(R_0 + R_L + \Gamma L) 4\pi r^2} (1 - 2ik_0 r) + ik_0 a \right], \end{aligned}$$

and the power emitted by the quasi punctual source is given by

$$\begin{aligned}
 P_r &= 4\pi a^2 \frac{1}{2} \operatorname{Re}[p_s v_s^*], \\
 &= \frac{1}{2} v_s \operatorname{Re}[F_s] = 2\pi a^2 \rho_0 c_0 v_s^2 k_0^2 a^2 \left[ 1 + \frac{S}{(R_0 + R_L + \Gamma L)4\pi r^2} \right]. \quad (6.253)
 \end{aligned}$$

In the absence of resonator ( $S \rightarrow 0$ ), the same source would radiate the following power (its vibration velocity is assumed not affected by the “acoustic load”):

$$P_\infty = 2\pi a^2 \rho_0 c_0 v_s^2 k_0^2 a^2. \quad (6.254)$$

The gain in power is then written

$$g = \frac{P_r}{P_\infty} = 1 + \frac{S}{(R_0 + R_L + \Gamma L)4\pi r^2}. \quad (6.255)$$

A quasi-punctual source with a constant strength, radiating at the resonance frequency of an empty bottle of wine and located at 1.5 cm from the opening of the bottle, can have a radiated power amplified by a factor  $g = 40$  with respect to its power in an infinite space. This corresponds to an increase of the acoustic field by approximately 15 dB.

## Chapter 7

# Diffusion, Diffraction and Geometrical Approximation

Following the example of Chapter 3, the objective of this chapter is to illustrate the integral formalism of linear problems of acoustics by considering situations the importance of which is recognized in acoustics and more generally in physics. Through these examples, some general laws are presented as well as few specific, but not unique, applications.

### 7.1. Acoustic diffusion: examples

The word diffusion comes from the Latin *diffusio (onis)*, meaning the action of spreading. This “spreading” concerns here the spatial distribution of acoustic energy from localized “sources”.

#### 7.1.1. *Propagation in non-homogeneous media*

In a finite space occupied by a perfect fluid initially at rest, a limited domain (D) is considered non-homogeneous. Non-homogeneity is introduced as a small deviation of the characteristics of this space (density and compressibility coefficient) from those of the surroundings. Acoustics sources exterior to the domain (D) are assumed to generate an incident harmonic wave (incident to the domain D) and the Sommerfeld’s condition at infinity is assumed to be satisfied.

The expression of the non-homogeneity of the fluid is introduced with the following notations:

$\rho_E$  denotes the static density in the non-homogeneous domain (D),

$\rho_0$  denotes the static density outside the domain (D),

$\delta\rho = \rho_E - \rho_0$  is assumed relatively small and it is function of the point considered,

$\chi_E$  denotes the coefficient of adiabatic compressibility of (D),

$\chi_0$  denotes the coefficient of adiabatic compressibility outside the domain (D),

$\delta\chi = \chi_E - \chi_0$  is assumed relatively small and it is function of the point considered.

The notation  $c_0$  which refers to the velocity is only used when related to the homogeneous region, outside the domain (D).

In such conditions, the problem considered in (D) is described by the equation of propagation (1.43) (Pékéris equation) that, within the approximation of linear acoustics, takes the form

$$\operatorname{div}\left(\frac{1}{\rho_E}\operatorname{grad} p\right) = \chi_E \frac{\partial^2}{\partial t^2} p, \text{ in (D),} \quad (7.1)$$

or, writing that  $c_0^{-2} = \rho_0\chi_0$ :

$$\Delta p - \frac{1}{c_0^2} \frac{\partial^2}{\partial t^2} p = \operatorname{div}\left(\frac{\delta\rho}{\rho_0}\operatorname{grad} p\right) + \frac{1}{c_0^2} \frac{\delta\chi}{\chi_0} \frac{\partial^2}{\partial t^2} p,$$

and, for a harmonic wave,

$$\left(\Delta + k^2\right)p_\omega = -k^2 \frac{\delta\chi}{\chi_0} p_\omega + \operatorname{div}\left(\frac{\delta\rho}{\rho_0}\operatorname{grad} p_\omega\right), \text{ in (D).} \quad (7.2)$$

The dissipation during the propagation is introduced in the expression of the wavenumber  $k$ .

Both terms on the right-hand side represent the effects of the non-homogeneous domain. They are null if  $\delta\rho = \delta\chi = 0$ . As a first approximation, the pressure  $p$  in these two terms is replaced by the pressure  $p_i$  generated by the sources in the medium outside (D) (Born's approximation). A more accurate approach can be carried out replacing the pressure  $p$  in the second term by the result obtained using Born's approximation before solving equation (7.2) again.

Within Born's approximation, the solution can be obtained using the integral equation (6.63), the chosen Green's function satisfying Sommerfeld's condition at infinity (equations (3.43) and (3.44)). With such an elementary field, the presence of the sources, far from the domain (D), is introduced by writing that the energy received by the diffusing medium is brought by an incident wave  $p_{\omega}^{(i)}(\vec{r})$  (corresponding to the volume integral in equation (6.63)). This function is a solution to  $(\Delta + k^2)p_{\omega}^{(i)} = 0$  and therefore can be used to obtain the general solution to equation (7.2) when associated with a corresponding particular solution.

Therefore, the integral solution for the diffusion of an incident wave  $p_{\omega}^{(i)}(\vec{r})$  by a non-homogeneous domain (D) within Born's approximation is written as

$$p_{\omega}(\vec{r}) = p_{\omega}^{(i)}(\vec{r}) + \iiint_{(D)} \left( k^2 \frac{\delta\chi}{\chi_0} p_{\omega}^{(i)} - \operatorname{div} \left[ \frac{\delta\rho}{\rho_0} \operatorname{grad}_0 p_{\omega}^{(i)} \right] \right) G(\vec{r}, \vec{r}_0) dD_0. \quad (7.3)$$

Since

$$\operatorname{div} \left[ \left( \frac{\delta\rho}{\rho_0} \operatorname{grad} p_{\omega}^{(i)} \right) \right] G = \operatorname{div} \left[ G \frac{\delta\rho}{\rho_0} \operatorname{grad} p_{\omega}^{(i)} \right] - \frac{\delta\rho}{\rho_0} \operatorname{grad} p_{\omega}^{(i)} \cdot \operatorname{grad} G$$

$$\text{and that } \iiint_{(D)} \operatorname{div} \left[ \left( \frac{\delta\rho}{\rho_0} \operatorname{grad} p_{\omega}^{(i)} \right) G \right] dD_0 = \iint_{S_0} \frac{\delta\rho}{\rho_0} \frac{\partial}{\partial n_0} \left( p_{\omega}^{(i)} \right) G dS_0 = 0,$$

where, by definition, the closed surface  $S_0$  contains the domain D ( $\delta\rho = \delta\chi = 0$  over  $S_0$ ), the integral equation (7.3) becomes

$$p_{\omega}(\vec{r}) = p_{\omega}^{(i)}(\vec{r}) + \iiint_{(D)} \left[ k^2 \frac{\delta\chi}{\chi_0} p_{\omega}^{(i)} G + \frac{\delta\rho}{\rho_0} \operatorname{grad}_0 p_{\omega}^{(i)} \cdot \operatorname{grad}_0 G \right] dD_0, \quad (7.4)$$

an integral over the domain (D) where  $\delta\chi \neq 0$  and  $\delta\rho \neq 0$ . This integral quantifies, at the first order of Born's approximation, the wave diffused by the non-homogeneous domain (D). It is presented as the superposition of a monopolar term (G) and a dipolar one ( $\operatorname{grad}_0 G$ ).

In the case where the observation point is at great distance from the domain (D), equation (5.180) leads to

$$G \approx \frac{e^{-ikr}}{4\pi r} e^{ik \frac{\vec{r} \cdot \vec{r}_0}{r}},$$



and to the solution in the form

$$p_\omega(\vec{r}) = p_\omega^{(i)}(\vec{r}) + P_i \frac{e^{-ikr}}{4\pi r} \Phi(\theta), \tag{7.5}$$

where  $P_i$  denotes the amplitude of the incident wave and where  $\Phi(\theta)$  denotes the following directivity factor (with  $\cos \theta = \frac{\vec{r} \cdot \vec{r}_0}{r r_0}$ ):

$$\Phi(D) = \iiint_{(D)} \left[ k^2 \frac{\delta\chi}{\chi_0} \frac{p_\omega^{(i)}}{P_i} + \frac{ik}{P_i} \frac{\delta\rho}{\rho_0} \frac{\vec{r}}{r} \cdot \text{grad}_0 p_\omega^{(i)} \right] e^{+ik \frac{\vec{r}}{r} \cdot \vec{r}_0} dD_0. \tag{7.6}$$

This directivity factor for the far field is nothing other than the three-dimensional Fourier transform of the term in brackets. In other words, it is the Fourier transform of the distribution of the factors that account for the absence of homogeneity in the domain (D) by the incident weighted wave  $p_\omega^{(i)}$  and its gradient. This is typical of this kind of diffusion processes in physics (optics, nuclear physics, etc.).

### 7.1.2. Diffusion on surface irregularities

Let a plane (S) be infinite and perpendicular to the  $\vec{Oz}$  axis where the local impedance  $Z_0 = \rho_0 c_0 / \beta_0$  is uniform except in a region (A) where the specific acoustic admittance is denoted  $\beta(x, y) \neq \beta_0$ . A harmonic incident wave  $p_\omega^{(i)}$  is reflected and diffused by this plane that limits the domain of propagation to the half-space  $z > 0$ . The expression of the resulting acoustic field is obtained from the integral equation (6.63) written as

$$p_\omega(\vec{r}) = p_\omega^{(0)}(\vec{r}) + \iint_{(S)} \left[ G(\vec{r}, \vec{r}_0) \frac{\partial p(\vec{r}_0)}{\partial n_0} - p(\vec{r}_0) \frac{\partial G(\vec{r}, \vec{r}_0)}{\partial n_0} \right] dS_0, \tag{7.7}$$

$p_\omega^{(0)}(\vec{r})$  denoting the sum of the incident wave and the reflected wave (by the plane of impedance  $Z_0$ ; see forthcoming section).

The Green's function is chosen to satisfy the boundary condition of a semi-infinite space delimited by a plane of specific admittance  $\beta_0$ , implying that

$$\left. \frac{\partial G}{\partial z_0} \right)_{z_0=0} = ik\beta_0 G)_{z_0=0}.$$

The immediately above equation is satisfied, in first approximation, by the following Green's function:

$$G \simeq \frac{e^{-ik|\vec{r}-\vec{r}_0|}}{4\pi|\vec{r}-\vec{r}_0|} + R_0 \frac{e^{-ik|\vec{r}-\vec{r}_0'|}}{4\pi|\vec{r}-\vec{r}_0'|}, \quad (7.8)$$

where  $R_0$  denotes the plane wave reflection coefficient of the surface  $S$  characterized at any given point by its specific admittance  $\beta_0$ .

The choice implies that the function  $p_\omega^{(0)}(\vec{r})$  represents the sum of the incident wave and the reflected wave (from  $S$ , with which is associated the uniform reflection coefficient  $R_0$ ). The boundary conditions are

$$\frac{\partial p}{\partial z_0} - ik\beta_0 p = 0, \text{ outside the domain (A),}$$

$$\frac{\partial p}{\partial z_0} - ik\beta(x,y)p = 0, \text{ at the frontier of (A),}$$

$$\text{or } \frac{\partial p}{\partial z_0} - ik\beta_0 p = ik(\beta - \beta_0)p, \text{ at the frontier of (A).}$$

The solution is then in the form:

$$p_\omega(\vec{r}) = p_\omega^{(0)}(\vec{r}) - ik \iint_A [\beta(x_0, y_0) - \beta_0] p_\omega(\vec{r}_0) G(\vec{r}, \vec{r}_0) dS_0. \quad (7.9)$$

In the particular case where the region containing the surface irregularities is limited and where the observation is carried out "far" from this domain, the solution (7.9) can be simplified by using equation (5.180):

$$G = \frac{e^{-ikr}}{4\pi r} \left[ e^{ik\frac{\vec{r}-\vec{r}_0}{r}} + R_0 e^{ik\frac{\vec{r}-\vec{r}_0'}{r}} \right].$$

Finally, assuming Born's approximation, equation (7.9) becomes, in the far-field region,

$$p_\omega(\vec{r}) = p_\omega^{(0)}(\vec{r}) + P_1 \frac{e^{-ikr}}{4\pi r} \Phi, \tag{7.10}$$

$$\text{with } \Phi = -ik \iint_A (\beta - \beta_0) \frac{p_\omega^{(0)}}{P_1} \left[ e^{ik\frac{\vec{r}}{r} \cdot \vec{r}_0} + R_0 e^{ik\frac{\vec{r}}{r} \cdot \vec{r}_0'} \right] dS_0,$$

where  $p_\omega^{(0)}(\vec{r})$  denotes the sum of the incident wave (of amplitude  $P_1$ ) and the wave reflected by an obstacle of uniformly distributed admittance  $\beta_0$  and where  $\Phi$  denotes the directivity factor characterizing the angular distribution of the diffused wave that is the two-dimensional Fourier transform of the perturbation  $(\beta - \beta_0)$  on the surface (A) (this property is general in physics).

### 7.2. Acoustic diffraction by a screen

The word diffraction comes from the Latin *diffRACTUS* meaning “decomposed into pieces”; it translates the deviation of waves when they meet an obstacle or an aperture.

#### 7.2.1. Kirchhoff-Fresnel diffraction theory

A punctual source is radiating in a space delimited by a screen with an aperture. The notations used hereinafter are as follows:

- S denotes the surface of the screen facing the source,
- S' denotes the surface of the screen not facing the source,
- A denotes a fictive surface covering the aperture,
- $P_s$  denotes a punctual source of source strength  $Q_0$ ,
- $P_r$  denotes the observation point,
- O denotes an origin (Figure 7.1).

The position of the receiver is noted  $\vec{r} = \vec{OP}_r$ , the source is located at  $\vec{s} = \vec{OP}_s$  and the vector  $\vec{r}_0 = \vec{OQ}$  is the position vector of a point on the surface A (at first,  $\vec{r}_0$  denotes also a point of S').

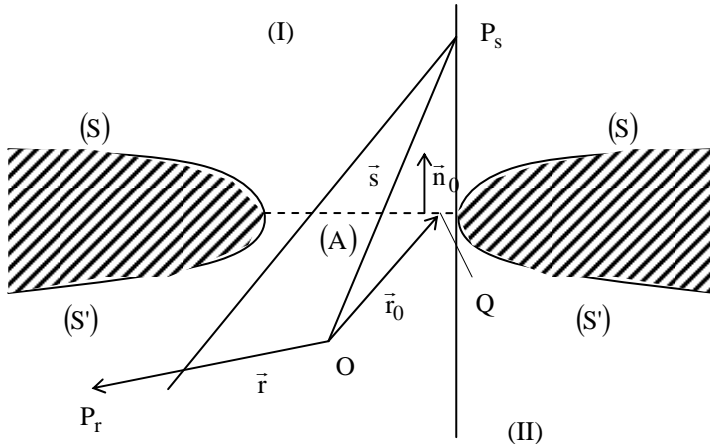

**Figure 7.1.** Aperture in a screen – notations

The field emitted by the punctual source  $P_s$  is assumed harmonic. The acoustic field is given by Helmholtz integral equation (6.63). In the receiving domain (noted II), half-space with no source and delimited by the surfaces A and  $S'$ , Helmholtz equation (6.63) becomes

$$p_\omega(\vec{r}) = \iint_{(A+S')} \left( G \frac{\partial p}{\partial n_0} - p \frac{\partial G}{\partial n_0} \right) dS_0, \quad (7.11)$$

the field being assumed to satisfy Sommerfeld's condition at infinity.

Solving this equation is greatly simplified by adopting Kirchhoff's hypotheses. Often used in optics, these hypotheses are more difficult to introduce in acoustics. However, they lead to an interesting and simple first approach.

Kirchhoff's first hypothesis stipulates that the fields  $p$  and  $\partial p / \partial n_0$  vanish at the surface  $S'$ . This is an acceptable assumption since the "stain" of diffraction is not spread (the wavelengths are small compared to the dimensions of the aperture A). The second hypothesis assumes that the field emitted by the punctual source at  $P_s$  in the domain (I) delimited by the surface A and S is not perturbed by the presence of the screen. The spherical geometry of the field is then conserved, which implies that A and S are perfectly absorbing surfaces. As a consequence of these two hypotheses, the surface integral over  $S'$  is null and the field  $p$  at the surface of A is nothing more than the incident spherical field. Hence:

$$p_\omega(\vec{r}) = \iint_{(A)} \left( G \frac{\partial p}{\partial n_0} - p \frac{\partial G}{\partial n_0} \right) dS_0, \quad (7.12)$$

$$\text{with } p = P_0 \frac{e^{-ik|\vec{s}-\vec{r}_0|}}{|\vec{s}-\vec{r}_0|} \text{ and } P_0 = \frac{ik\rho c Q_0}{4\pi},$$

where  $Q_0$  denotes the source strength of  $P_s$ .

Similarly to all the other relations presented in this chapter, the above result is an expression of Huygens' principle according to which the resulting field is the superposition of the elementary fields created by each elementary source of the surface (A).

Note: Babinet's principle introduces the figures of diffraction of two complementary screens so that the aperture (A) of the first screen coincides perfectly with the opaque region (S) of the other screen. Consequently, if one denotes  $p_1$  the field at the point  $P_r$  when a first screen is placed between  $P_r$  and  $P_s$ ,  $p_2$  the field at the same point  $P_r$  when the first screen is replaced by its complementary and  $p$  the field at  $P_r$  when there is no screen between  $P_r$  and  $P_s$ , then equation (7.12) leads to

$$p_1 = \iint_{(A_1)} (G \partial_{n_0} p - p \partial_{n_0} G) dS_0,$$

$$p_2 = \iint_{(A_2)} (G \partial_{n_0} p - p \partial_{n_0} G) dS_0,$$

$$p = \iint_{(A_1+A_2)} (G \partial_{n_0} p - p \partial_{n_0} G) dS_0,$$

and finally to Babinet's principle:

$$p = p_1 + p_2.$$

### 7.2.2. Fraunhofer's approximation

This approximation leads to an estimate of the solution to equation (7.12) when the point source and the observation point are significantly far from the screen's aperture. Fraunhofer's approximation is a derivation at the first order of  $r_0/r$  and  $r_0/s$  of the functions  $p$ ,  $G$  and their normal derivatives, both  $p$  and  $G$  denoting a monopolar field. In the following calculations, the screen is assumed plane and the shape of the aperture is undefined (Figure 7.2).

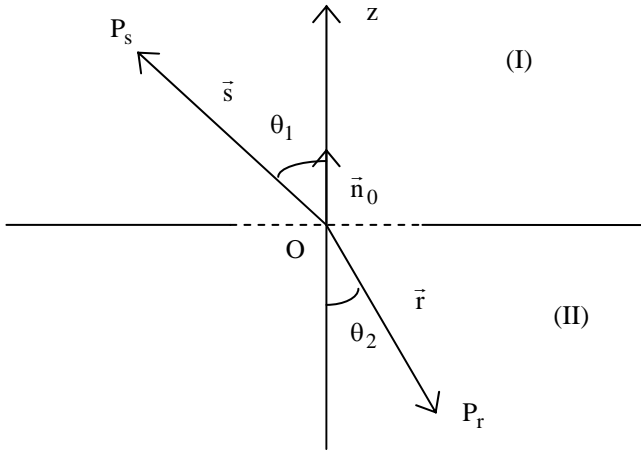

**Figure 7.2.** Diffraction by an aperture in a plane screen

The origin  $O$  is located at the aperture and the  $\vec{Oz}$  axis is chosen perpendicular to the plane. At the first order of  $r_0/r'$  (equation 5.180):

$$|\vec{r}' - \vec{r}_0| \simeq r' - \frac{\vec{r}' \cdot \vec{r}_0}{r'}$$

(where  $\vec{r}'$  denotes  $\vec{r}$  or  $\vec{s}$ ), thus

$$\frac{e^{-ik|\vec{r}' - \vec{r}_0|}}{4\pi|\vec{r}' - \vec{r}_0|} \simeq \frac{e^{-ikr'}}{4\pi r'} e^{ik \frac{\vec{r}' \cdot \vec{r}_0}{r'}} \quad (7.13)$$

and considering expression (6.140) of  $|\vec{r}' - \vec{r}_0|$ ,

$$\begin{aligned} \frac{\partial}{\partial n_0} \left[ \frac{e^{-ik|\vec{r}' - \vec{r}_0|}}{4\pi|\vec{r}' - \vec{r}_0|} \right] &= \frac{\partial}{\partial z_0} \left[ \frac{e^{-ik|\vec{r}' - \vec{r}_0|}}{4\pi|\vec{r}' - \vec{r}_0|} \right] \simeq \frac{\cos(\vec{n}_0, \vec{r}' - \vec{r}_0)}{4\pi|\vec{r}' - \vec{r}_0|} ik \left[ 1 - \frac{i}{k|\vec{r}' - \vec{r}_0|} \right] e^{-ik|\vec{r}' - \vec{r}_0|} \\ &\simeq ik \cos(\vec{n}_0, \vec{r}' - \vec{r}_0) \frac{e^{-ikr'}}{4\pi r'} e^{ik \frac{\vec{r}' \cdot \vec{r}_0}{r'}} \end{aligned} \quad (7.14)$$

where, for  $\vec{r}' = \vec{r}$ ,

$$\cos(\vec{n}_0, \vec{r} - \vec{r}_0) \simeq \cos(\vec{n}_0, \vec{r}) = \cos(\pi - \theta_2) = -\cos \theta_2,$$

and for  $\vec{r}' = \vec{s}$ ,

$$\cos(\vec{n}_0, \vec{s} - \vec{r}_0) \simeq \cos(\vec{n}_0, \vec{s}) = \cos \theta_1.$$

Consequently, the expression (equation (7.12)) of the diffracted acoustic pressure in the region (II) becomes

$$p_\omega(\vec{r}) \simeq B \iint_{(A)} e^{ik\left(\frac{\vec{r}}{r} + \frac{\vec{s}}{s}\right) \cdot \vec{r}_0} dS_0, \tag{7.15}$$

$$\text{with } B = \frac{ikP_0}{4\pi} (\cos \theta_1 + \cos \theta_2) \frac{e^{-ik(r+s)}}{rs}. \tag{7.16}$$

Using the following notations for the components of  $\vec{r}$ ,  $\vec{s}$  and  $\vec{r}_0$  in the plane of the screen ( $\bar{O}x$  and  $\bar{O}y$ ):

$$\begin{aligned} \left(\frac{\vec{r}}{r}\right)_x = \ell, \quad \left(\frac{\vec{r}}{r}\right)_y = m, \quad \left(\frac{\vec{s}}{s}\right)_x = -\ell_i, \quad \left(\frac{\vec{s}}{s}\right)_y = -m_i, \quad (\vec{r}_0)_x = \xi \text{ and} \\ (\vec{r}_0)_y = \eta, \end{aligned} \tag{7.17}$$

the solution (equation (7.15)) becomes

$$p_\omega(\vec{r}) \approx B \iint_{(A)} e^{ik[(\ell - \ell_i)\xi + (m - m_i)\eta]} d\xi d\eta. \tag{7.18}$$

The figure of diffraction is nothing more, once again, than the two-dimensional (spatial) Fourier transform of a characteristic domain of the problem, here the aperture (A).

Note: as the reciprocity law applies, there is complete symmetry with respect to the permutation of the source and observation points. Moreover, if the dimensions of the aperture are great (as is the case of semi-infinite screen) these approximations do not hold and Fraunhofer's solution is not acceptable anymore.

### 7.2.3. Fresnel's approximation

When the figure of diffraction is analyzed in the fixed plane (of the space) that contains the axis perpendicular to the screen  $\bar{O}z$  and the point source  $P_s$  (Figure 7.3), it is convenient to chose the  $\bar{O}x$  axis along the projection of the vector  $\vec{P}_s P_r$

onto the  $(x, y)$ -plane of the screen. Moreover, by choosing the origin of the coordinate system at the intersection between the line  $P_s P_r$  with the plane of the screen (depending therefore on the location of these two points) and by denoting  $\delta$  the angle between the line  $P_s P_r$  and the  $\vec{Oz}$  axis (Figure 7.4), one obtains

$$\ell_i = \ell = \sin \delta \quad \text{and} \quad m_i = m = 0.$$

Consequently, the argument of the exponential term in equation (7.18) vanishes; this double integral is then simply equal to the area of the aperture (A). In these conditions, the observed non-uniform figure of diffraction can only be described using a second-order approximation, called Fresnel's approximation.

At the second order of  $r_0 / r'$  (equation (5.180))

$$|\vec{r}' - \vec{r}_0| \simeq r' - \frac{\vec{r}' \cdot \vec{r}_0}{r'} + \frac{r_0^2}{2r'} - \frac{(\vec{r}' \cdot \vec{r}_0)^2}{2r'^3},$$

$$\text{thus } |\vec{r} - \vec{r}_0| \simeq r - (\ell\xi + m\eta) + \frac{\xi^2 + \eta^2}{2r} - \frac{(\ell\xi + m\eta)^2}{2r},$$

$$\text{and } |\vec{s} - \vec{r}_0| \simeq s + (\ell_i\xi + m_i\eta) + \frac{\xi^2 + \eta^2}{2s} - \frac{(\ell_i\xi + m_i\eta)^2}{2s}.$$

So that for  $\ell_i = \ell = \sin \delta$  and  $m_i = m = 0$ , one obtains

$$|\vec{r} - \vec{r}_0| + |\vec{s} - \vec{r}_0| \simeq r + s + f(\xi, \eta), \quad (7.19)$$

$$\text{with } f(\xi, \eta) = \frac{1}{2} \left( \frac{1}{r} + \frac{1}{s} \right) (\xi^2 \cos^2 \delta + \eta^2). \quad (7.20)$$



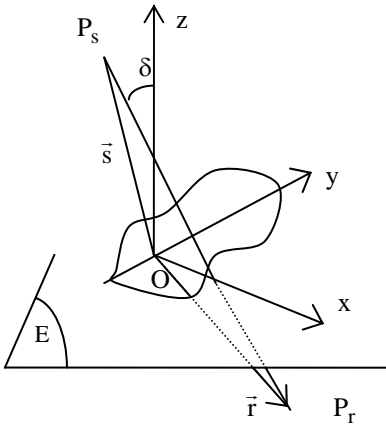

**Figure 7.3.** Coordinate system of Fresnel's approximation

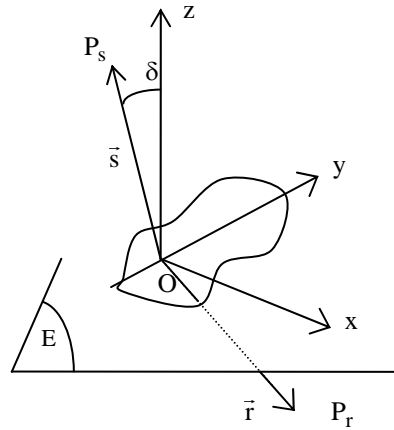

**Figure 7.4.** Origin of the axis system on  $P_s P_r$

The solution to equation (7.18) then becomes

$$p_{\omega} = B \iint_{(A)} e^{-ikf(\xi, \eta)} d\xi d\eta \quad , \quad (7.21)$$

the amplitude factor B being

$$B = \frac{iP_0}{\lambda} \frac{e^{-ik(r+s)}}{rs} \cos(\delta) \quad , \quad (7.22)$$

where  $\lambda$  is the wavelength.

This result can also be written as

$$p = B(C - iS) \quad , \quad (7.23)$$

$$\text{with } C = \iint_{(A)} \cos[kf(\xi, \eta)] d\xi d\eta \quad \text{and } S = \iint_{(A)} \sin[kf(\xi, \eta)] d\xi d\eta \quad .$$

The following change of variables

$$\frac{\pi}{2} u^2 = \frac{\pi}{\lambda} \left( \frac{1}{r} + \frac{1}{s} \right) \xi^2 \cos^2 \delta \quad \text{and} \quad \frac{\pi}{2} v^2 = \frac{\pi}{\lambda} \left( \frac{1}{r} + \frac{1}{s} \right) \eta^2 \quad , \quad (7.24)$$

implies that  $d\xi d\eta = \frac{\lambda}{2} \frac{du dv}{\left(\frac{1}{r} + \frac{1}{s}\right) \cos \delta}$  and consequently:

$$C = b \iint_{(A)} \cos \left[ \frac{\pi}{2} (u^2 + v^2) \right] du dv$$

$$\text{and } S = b \iint_{(A)} \sin \left[ \frac{\pi}{2} (u^2 + v^2) \right] du dv \quad , \quad (7.25)$$

$$\text{with } b = \frac{\lambda}{2 \left( \frac{1}{r} + \frac{1}{s} \right) \cos \delta} . \quad (7.26)$$

The functions  $C$  and  $S$  are simple linear combinations of Fresnel's integrals (equation (6.171)), the expressions of which are given in the following section.

**7.2.4. Fresnel's diffraction by a straight edge**

A perfectly reflecting and infinitely thin screen (E), in the (xOy)-plane, is bounded by the line (dd') parallel to the  $\vec{Oy}$  axis and located at the abscissa  $x$  (Figure 7.5). The origin  $O$  is chosen belonging to the line  $P_r P_s$ . Thus, if  $x$  is positive, the receiving point  $P_r$  belongs to the "lighted" region and if  $x$  is negative, it belongs to the "shadowed" region.

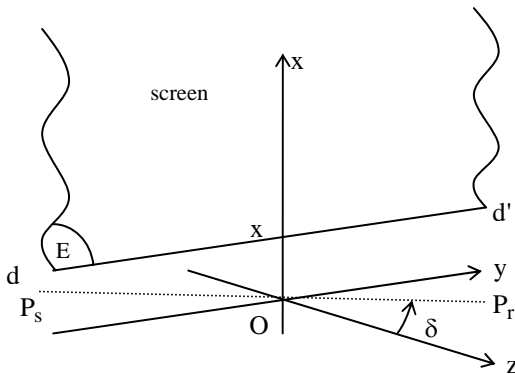

**Figure 7.5.** Plane screen with a straight edge (notations)

The domain of variation of the variables  $\xi$  and  $\eta$  are

$$-\infty < \xi < x \quad \text{and} \quad -\infty < \eta < \infty, \quad (7.27)$$

and consequently, those of the variables  $u$  and  $v$  are

$$-\infty < u < w \quad \text{and} \quad -\infty < v < \infty, \quad (7.28)$$

$$\text{with } w = \sqrt{\frac{2}{\lambda} \left( \frac{1}{r} + \frac{1}{s} \right)} x \cos \delta.$$

The integrals (equation (7.25)) then become

$$C = b \int_{-\infty}^w du \int_{-\infty}^{\infty} dv \left[ \cos\left(\frac{\pi}{2} u^2\right) \cos\left(\frac{\pi}{2} v^2\right) - \sin\left(\frac{\pi}{2} u^2\right) \sin\left(\frac{\pi}{2} v^2\right) \right], \quad (7.29)$$

$$S = b \int_{-\infty}^w du \int_{-\infty}^{+\infty} dv \left[ \sin\left(\frac{\pi}{2} u^2\right) \cos\left(\frac{\pi}{2} v^2\right) + \cos\left(\frac{\pi}{2} u^2\right) \sin\left(\frac{\pi}{2} v^2\right) \right]. \quad (7.30)$$

Considering the definitions (6.171) of the above functions and their properties (6.175), these functions can be expressed, using the Fresnel's integrals, as follows

$$C = b \left\{ \left[ \frac{1}{2} + \mathbf{e}(w) \right] - \left[ \frac{1}{2} + \mathbf{S}(w) \right] \right\} = b [\mathbf{e}(w) - \mathbf{S}(w)], \quad (7.31)$$

$$S = b \left\{ \left[ \frac{1}{2} + \mathbf{e}(w) \right] + \left[ \frac{1}{2} + \mathbf{S}(w) \right] \right\} = b [1 + \mathbf{e}(w) + \mathbf{S}(w)]. \quad (7.32)$$

Finally, the relative amplitude of the diffracted pressure field

$$p_d = B(C - iS), \quad (7.33)$$

is given by

$$\left| \frac{p_d}{p_i} \right| = \frac{1}{\sqrt{2}} \sqrt{\left[ \frac{1}{2} + \mathbf{e}(w) \right]^2 + \left[ \frac{1}{2} + \mathbf{S}(w) \right]^2}, \quad (7.34)$$

where  $|p_i| = \frac{P_0}{r+s}$  denotes the amplitude of the incident wave at the receiving point

$P_r$  derived as if there was no screen.

The profile of the function described by equation (7.34) is represented in Figure 7.6.

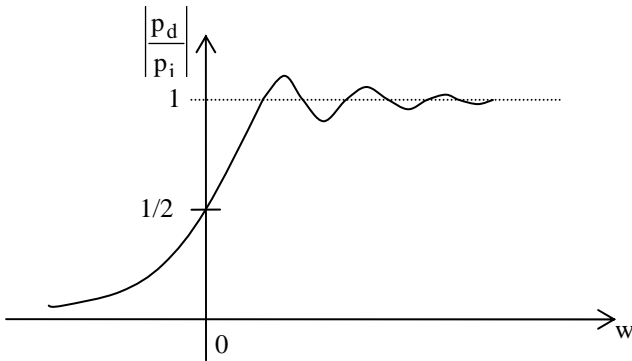

**Figure 7.6.** Normalized amplitude of the pressure field diffracted by a straight edge ( $w > 0$  corresponds to the “lighted” region while  $w < 0$  corresponds to the “shadowed” region)

Note: the lower bound of integration tending to  $-\infty$  in equations (7.29) and (7.30) leads to the factors  $1/2$  of equations (7.31) and (7.32). According to equation (6.175), limiting these limits down to  $-4$ , rather than  $-\infty$ , has little effect on the result. In other words, the contribution to the diffracted pressure field of the points located at a distance from the edge that is greater than a given minimum (related to  $-4$  here) is negligible. This justifies the use of Fresnel’s approximation ( $r \gg r_0$ ) for apertures of infinite extent.

### 7.2.5. Diffraction of a plane wave by a semi-infinite rigid plane: introduction to Sommerfeld’s theory

The objective of this section is to find a solution to the problem of diffraction of a plane wave incident to a parallel straight edge (of a perfectly reflecting plane). More precisely, a harmonic plane wave is propagating in the direction  $x < 0$  and is incident to a semi-infinite plane the edge of which coincides with the line  $x = y = 0$ ,  $-\infty < z < \infty$  and the angle of which with the  $\vec{O}x$  axis is set to be equal to  $\left(\frac{3\pi}{2} - \psi\right)$  with  $-\frac{\pi}{2} < \psi < \frac{\pi}{2}$  (in the case of Figure 7.7,  $\psi$  is positive). This problem can be solved by adopting a different method to those already introduced, particularly since Kirchhoff’s hypotheses are often too restrictive.

The considered space is divided into three regions:

$$\text{region (I), } -2\psi < \varphi < \pi, \tag{7.35a}$$

$$\text{region (II), } -\frac{\pi}{2} - \psi < \varphi < -2\psi, \tag{7.35b}$$

$$\text{region (III), } \pi < \varphi < \frac{3\pi}{2} - \psi. \tag{7.35c}$$

In the first region, the incident wave can be described by  $Ae^{ikx} = Ae^{ikw \cos \varphi}$  where  $w$  denotes the distance separating the observation point  $P$  to the edge of the screen (the origin of the vector  $\vec{w}$  is chosen as the origin of the coordinate system).

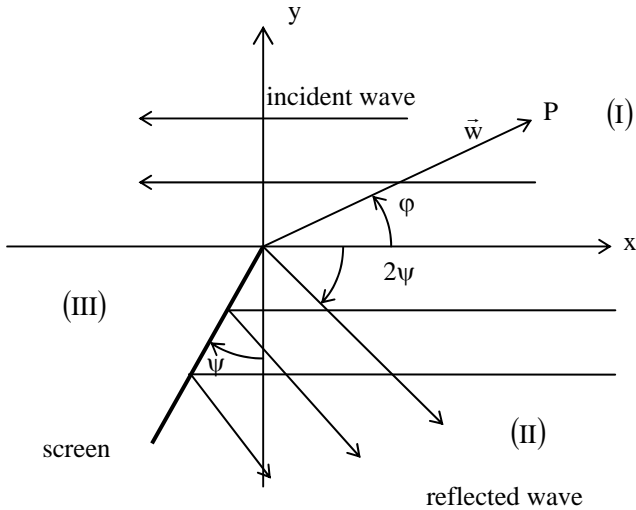

**Figure 7.7.** Diffraction of a plane wave by a straight edge

Using cylindrical coordinates  $(w, \varphi, z)$  seems more appropriate with respect to the symmetry of the problem. The incident plane wave can then be expanded on the basis associated with the considered space as follows:

$$Ae^{ikw \cos \varphi} = A \sum_{n=0}^{\infty} (2 - \delta_{n0}) (i)^n \cos(n\varphi) J_n(kw). \tag{7.36}$$

The solution to the problem is built from the function

$$U(w, \varphi) = \frac{1}{2} A \sum_{m=0}^{\infty} (2 - \delta_{m0}) (i)^{m/2} \cos\left(\frac{m}{2} \varphi\right) J_{m/2}(kw), \quad (7.37)$$

as follows:

$$p(w, \varphi) = A[U(w, \varphi) + U(w, 3\pi - \varphi - 2\psi)]. \quad (7.38)$$

The choice of expansion (equation (7.37)) is partly motivated by the fact that the acoustic pressure on one side of the screen is different from the acoustic pressure on the other side. This implies that for  $\varphi = 3\frac{\pi}{2} - \psi$ , the solution cannot be equal to the one obtained for  $\varphi = -\frac{\pi}{2} - \psi + 2\pi$ ; the function  $U$ , periodic with a period of  $4\pi$ , satisfies this condition in the interval  $\varphi \in (0, 2\pi)$ . Moreover, without the screen or when the screen (assumed infinitely thin) is located at  $\psi = \pi/2$ , the solution (equation (7.38)) must be identical to the expression (equation (7.36)) of the incident wave. It is straightforward to verify the equivalence of the solution (7.38) with the expression (7.36) since all the terms with odd  $m$  in equation (7.38) are then null. Finally, the solution (7.38) is indeed the solution to the problem written as

$$(\Delta + k^2)p = 0 \text{ in the entire space,} \quad (7.39a)$$

$$\frac{\partial p}{\partial \varphi} = 0 \text{ on the screen for } \varphi = 3\frac{\pi}{2} - \psi \text{ and } \varphi = -\frac{\pi}{2} - \psi, \quad (7.39b)$$

$$\text{incident harmonic plane wave in the negative } x \text{-direction.} \quad (7.39c)$$

The solution (7.38) can also be written separating the terms corresponding to the incident, reflected and diffracted waves (this derivation is not detailed herein), leading to

$$U(w, \varphi) = e^{ikw \cos \varphi} \left[ 1 + F\left(\sqrt{2kw} \cos\left(\frac{\varphi}{2}\right)\right) \right], \quad (7.40a)$$

and implying that

$$U(w, 3\pi - \varphi - 2\psi) = e^{-ikw \cos \varphi} \left[ 1 + F\left(\sqrt{2kw} \cos\left(\frac{3\pi}{2} - \frac{\varphi}{2} - \psi\right)\right) \right], \quad (7.40b)$$

$$\text{where } F(z) = \frac{1}{2} \left( \mathcal{E} \left( \sqrt{\frac{2}{\pi}} z \right) + \mathcal{S} \left( \sqrt{\frac{2}{\pi}} z \right) - 1 + i \left[ \mathcal{E} \left( \sqrt{\frac{2}{\pi}} z \right) - \mathcal{S} \left( \sqrt{\frac{2}{\pi}} z \right) \right] \right). \quad (7.40c)$$

The asymptotic approximation of Fresnel’s integrals leads, for each region in Figure 7.7, to the following results:

i) In region (III), in the geometrical “shadow”, the diffracted wave presents the characteristics of a cylindrical wave and takes the following form:

$$p_{III}(w, \varphi) = A \frac{1+i}{4\sqrt{\pi k w}} e^{-ikw} \left[ \frac{G(\psi + \varphi/2)}{\sin(\psi + \varphi/2)} - \frac{G(\varphi/2)}{\cos(\varphi/2)} \right], \quad (7.41)$$

where the function  $G$  is equal to one, except at the vicinity of the values of  $\varphi$  and  $\psi$  for which the denominators are null, i.e. at the vicinity of the boundary between the geometrical shadows of the incident wave ( $\varphi = \pi$ ) and of the reflected wave ( $\varphi = -2\psi$ ), where it expresses the continuity of the pressure field.

ii) In region (I), the acoustic field is the sum of the incident and diffracted fields

$$p_I(w, \varphi) = A e^{ikw \cos \varphi} + p_{III}(w, \varphi). \quad (7.42)$$

iii) In region (II), the acoustic field is the sum of the incident, reflected and diffracted fields:

$$p_{II}(w, \varphi) = A e^{-ikw \cos(\varphi+2\psi)} + p_I(w, \varphi). \quad (7.43)$$

Note: the profile of the solution is similar to the one shown in Figure 7.6.

*Digression on the theories of Sommerfeld and MacDonald*

The theories of Sommerfeld and MacDonald, briefly presented in this digression, can be considered as generalizations of the above theory. Apart from the problem of a semi-infinite plane screen, these theories lead to the solution to the problem of diffraction by a prism. Sommerfeld’s theory applies to the incident plane waves, while MacDonald’s theory applies to incident spherical waves. The principle of the method applied to an incident plane wave and a semi-infinite plane screen is here presented. The screen is a surface where the analytical function describing the acoustic field takes two different values. From a mathematical point of view, these particular analytical functions can be considered as taking a unique value in the complex space of Riemann’s functions (double layered when a plane screen is considered). If the direction of observation is taken along the  $\bar{O}x$  axis, the incident plane wave is described by

$$e^{-ikr \cos(\varphi-\gamma)}, \quad (7.44)$$

where  $\gamma$  and  $\varphi$  denote respectively the position of the screen and the direction of observation.

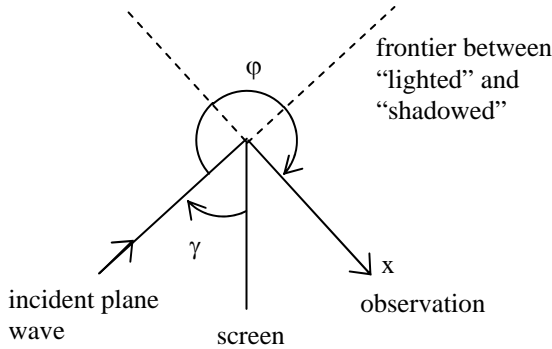

**Figure 7.8.** Notations for the diffraction by a screen with a straight edge

By applying Cauchy’s theorem, the expression of the incident wave becomes

$$e^{-ikr\cos(\varphi-\gamma)} = \frac{1}{2\pi} \oint_{(c)} \frac{e^{i\beta}}{e^{i\beta} - e^{i\gamma}} e^{-ikr\cos(\varphi-\beta)} d\beta \tag{7.45}$$

where  $(c)$  denotes a closed contour of integration including the point  $\beta = \gamma$ .

The chosen auxiliary function, of period  $4\pi$ , from which the solution can be built (following the example of the previous section) can be written as

$$U = \frac{1}{4\pi} \oint_{(c)} \frac{e^{i\beta/2}}{e^{i\beta/2} - e^{i\gamma/2}} e^{-ikr\cos(\beta-\varphi)} d\beta, \tag{7.46}$$

and finally (the details are not presented herein), the solution is

$$p = U(\varphi - \gamma) + U(\varphi + \gamma). \tag{7.47}$$



**7.2.6. Integral formalism for the problem of diffraction by a semi-infinite plane screen with a straight edge**

A perfectly rigid and infinitely thin plane screen, perpendicular to the  $\vec{O}y$  axis, is bounded by a line of equation  $x = y = 0$ . It is responsible for the reflection and diffraction of a harmonic plane wave ( $y > 0$ ) assumed depending on the  $x$  and  $y$  coordinates (pulsating line source parallel to the  $\vec{O}z$  axis). The problem can therefore be written in two dimensions.

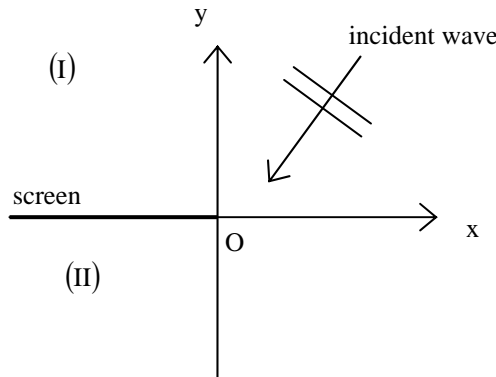

**Figure 7.9.** Notations for the diffraction of a harmonic plane wave by a screen with a straight edge

The considered space is divided into two regions (I) and (II) corresponding, respectively, with the  $y > 0$  and  $y < 0$  domains. The integral equation of the problem (6.63) is expressed in each of these domains, choosing for each case a Green, function the normal derivative of which vanishes in the  $xOz$  plane (the surface of equation  $y = 0$  is denoted “S”).

This Green’s function can be written, following the same method presented in section (6.1.4.1) and considering equation (3.50), in the form

$$G(\vec{r}, \vec{r}_0) = g_i(\vec{r}, \vec{r}_0) + g_r(\vec{r}, \vec{r}_0'), \tag{7.48}$$

$$\text{with } g_i(\vec{r}, \vec{r}_0) = -\frac{i}{4} H_0^-(k|\vec{r} - \vec{r}_0|) \tag{7.49a}$$

$$\text{and } g_r(\vec{r}, \vec{r}_0) = -\frac{i}{4} H_0^-(k|\vec{r} - \vec{r}_0'|), \tag{7.49b}$$

$$\text{where } |\vec{r} - \vec{r}_0| = \sqrt{(x - x_0)^2 + (y - y_0)^2}$$

$$\text{and } |\vec{r} - \vec{r}'_0| = \sqrt{(x - x_0)^2 + (y + y_0)^2}.$$

This Green's function represents the velocity potential created by a pulsating line source and its image source, of unit linear strength, parallel to the  $\vec{Oz}$ , of coordinates  $(x_0, y_0)$ .

If the point  $\vec{r}_0$  belongs to the surface (S) ( $y_0 = 0$ ), Green's function is, for any given point in the half-space considered ( $y > 0$  or  $y < 0$ ), in the form

$$[G(\vec{r}, \vec{r}_0)]_{y_0=0} = 2[g_i]_{y_0=0} = 2[g_r]_{y_0=0} = -\frac{i}{2} H_0^- \left( k \sqrt{(x - x_0)^2 + y^2} \right). \quad (7.50)$$

The integral equations of problems at the boundaries considered here can then be written, according to Sommerfeld's condition at infinity, in the  $y < 0$  domain, as

$$p_- = \int_{-\infty}^{\infty} G(x, y; x_0, 0) \frac{\partial}{\partial y_0} p_-(x_0, 0) dx_0, \quad (7.51)$$

and, in the  $y > 0$  domain, as

$$p_+ = \int_{-\infty}^{+\infty} \int_0^{\infty} G(x, y; x_0, y_0) F(x_0, y_0) dx_0 dy_0$$

$$- \int_{-\infty}^{+\infty} G(x, y; x_0, 0) \frac{\partial}{\partial y_0} p_+(x_0, 0) dx_0, \quad (7.52)$$

where

$$\int_{-\infty}^{\infty} \int_0^{\infty} G F dx_0 dy_0 = \int_{-\infty}^{\infty} \int_0^{\infty} (g_i + g_r) F dx_0 dy_0 = p_i + p_r, \quad (7.53)$$

is the sum of the incident pressure  $p_i$  (assumed known and independent of the coordinate  $z$ ) from the real sources and the pressure  $p_r$  created by their image sources (with respect to the plane  $y = 0$ ).

These solutions satisfy Neumann's conditions at the surface of the screen. However, for the problem to be properly posed, one needs to write the conditions of continuity between the two regions considered of the acoustic pressure and particle velocity at  $y = 0$ ,  $x > 0$ :

$$p_+ = p_- \text{ and } \vec{\nabla} p_+ = \vec{\nabla} p_- \text{ for } y = 0, x > 0. \quad (7.54)$$

By noting that on the surface (S), the normal derivative of  $(p_i + p_r)$  is null, the condition of continuity of the particle velocity at  $y = 0$  for  $x > 0$  and the condition of null normal velocity on the screen for  $x < 0$  give

$$\left( \frac{\partial}{\partial y_0} p_+ \right)_{y_0=0} = \left( \frac{\partial}{\partial y_0} p_- \right)_{y_0=0}, \quad \forall x, \quad (7.55)$$

$$\text{and } \left( \frac{\partial}{\partial y_0} p_{\pm} \right)_{y_0=0} = 0, \text{ for } x < 0. \quad (7.56)$$

Consequently,

$$\begin{aligned} \int_{-\infty}^{\infty} G(x, y; x_0, 0) \frac{\partial}{\partial y_0} p_+(x_0, 0) dx_0 &= - \int_0^{\infty} G(x, y; x_0, 0) \frac{\partial}{\partial y_0} p_+(x_0, 0) dx_0 \\ &= - \int_{-\infty}^{\infty} G(x, y; x_0, 0) \frac{\partial}{\partial y_0} p_-(x_0, 0) dx_0 = - \int_0^{\infty} G(x, y; x_0, 0) \frac{\partial}{\partial y_0} p_-(x_0, 0) dx_0. \end{aligned}$$

In the domain  $y < 0$ , the integral equations for the problems at the boundaries considered are

$$p_- = -\frac{i}{2} \int_0^{\infty} H_0^- \left( k \sqrt{(x-x_0)^2 + y^2} \right) \frac{\partial}{\partial y_0} p_-(x_0, 0) dx_0, \quad (7.57)$$

and in the domain  $y > 0$

$$p_+ = p_i + p_r + \frac{i}{2} \int_0^{\infty} H_0^- \left( k \sqrt{(x-x_0)^2 + y^2} \right) \frac{\partial}{\partial y_0} p_-(x_0, 0) dx_0. \quad (7.58)$$

One still needs to write the condition of continuity of the pressures at  $y = 0$ ,  $x > 0$

$$p_+(x > 0, y = 0) = p_-(x > 0, y = 0).$$

Substituted into the integral equations (7.57) and (7.58) and considering that by definition  $p_r(x, 0) = p_i(x, 0)$ , this condition leads to

$$2p_i(x, 0) = -i \int_0^{\infty} H_0^-(k|x-x_0|) \frac{\partial}{\partial y_0} p_-(x_0, 0) dx_0, \text{ for } x > 0. \quad (7.59)$$

By solving the integral equation (7.59), one obtains the function  $\partial_{y_0} p_-(x_0, 0)$  which, substituted into equations (7.57) and (7.58), gives the solutions  $p_+(x, y)$  and  $p_-(x, y)$ . In the case of a harmonic plane wave, this procedure is lengthy and leads to the solutions already presented in the previous section.

### 7.2.7. Geometric theory of Diffraction of Keller (GTD)

The geometric theory of diffraction is a generalization of the classical geometric theory that associates a fictive ray to a wavefront. It is used herein to explain the phenomena associated to diffraction. The ray is defined as a trajectory perpendicular to the wavefront. To each point of the trajectory are associated the corresponding amplitude and phase of the perturbation. Fermat's principle is a particular example of this theory, and it is presented in section 7.3.

The basic principle of the classical theory assumes that the propagation is a local phenomenon, meaning that it only depends on the properties of the medium and structure of the field at the vicinity of the considered point. For any given point of the considered space, the acoustic field results from the contributions of all rays passing through that point. Furthermore, the direction of the rays diffracted by an edge is determined by rules resulting directly from Fermat's principle. The laws of geometric optics can then be applied to acoustics on the condition that the amplitudes and phases associated with the diffracted rays are derived from the asymptotic approximations of the "rigorous" solutions. A "ray" provides a picture of a line drawn by an infinitely thin pencil.

#### 7.2.7.1. Tracing diffracted rays

An incident plane wave is diffracted by a thin and perfectly reflecting screen (semi-infinite with a straight edge) and the resulting diffracted wave presents cylindrical characteristics. This suggests the following hypothesis: the diffracted rays make with the tangent to the edge of the screen at the point of diffraction the same angle as that made by the incident ray, but in the opposite side of the plane normal to the edge of the screen at the diffraction point. The rays are consequently distributed over the surface of a cone (Figure 7.10).

This hypothesis is in reality a consequence of Fermat's principle.

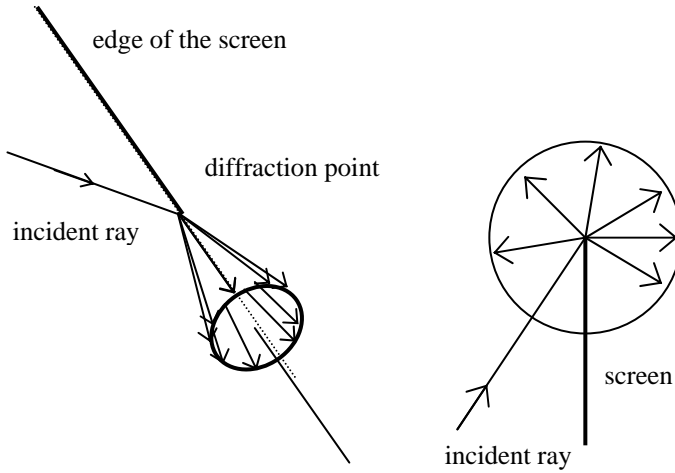
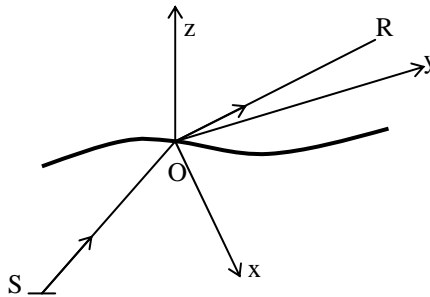

**Figure 7.10.** Diffraction of a ray by the edge of a screen (side views)

When considering a ray from a point  $S$  diffracted by the edge of a screen at the point  $O$  and passing through a point  $R$  (Figure 7.11), and defining the axis  $\bar{O}y$  coinciding with the tangent to the edge of the screen at the point  $O$ , Fermat's principle can be written as

$$\frac{d(SO + OR)}{dy} = 0 \text{ or } \frac{d(SO)}{dy_S} = -\frac{d(OR)}{dy_R}, \tag{7.60}$$

since the distances  $SO$  and  $OR$  vary similarly if the variation  $dy$  is replaced by  $-dy_S$  or  $-dy_R$  (where  $y_S$  and  $y_R$  denote, respectively, the second coordinate of the point source and the observation point).



**Figure 7.11.** Diffraction of a ray by the edge of a screen

By writing

$$SO = \sqrt{x_S^2 + y_S^2 + z_S^2} \quad \text{and} \quad OR = \sqrt{x_R^2 + y_R^2 + z_R^2},$$

equation (7.60) becomes

$$\frac{y_S}{\sqrt{x_S^2 + y_S^2 + z_S^2}} = -\frac{y_R}{\sqrt{x_R^2 + y_R^2 + z_R^2}}, \quad (7.61)$$

thus, if  $\varphi_S$  and  $\varphi_R$  denote the angles between the  $\bar{O}y$  axis and, respectively, the incident and diffracted ray:

$$\sin \varphi_S = -\sin \varphi_R. \quad (7.62)$$

The rays are therefore distributed over the surface of a cone.

#### 7.2.7.2. Notions of critical points and caustics, energy flow conservation

Two incident rays, (1) and (2), are associated with two cones of diffraction. It can happen that the diffracted rays are intersecting over certain curves (called caustics). These curves are limited by the critical points ( $O_1, O'_1, P_1$  and  $P'_1$  in Figure 7.12).

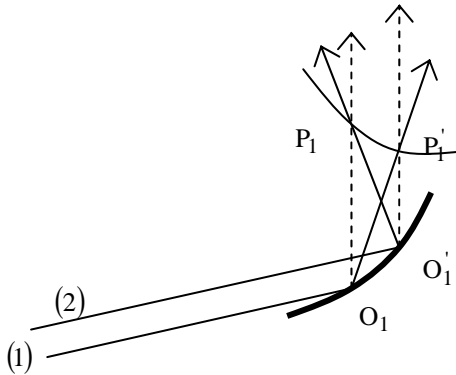

**Figure 7.12.** Critical points and caustics

The law of conservation of the energy flow can be graphically expressed by considering an elementary tube delimited by several rays (which are extremely close to each other). The most general representation of this approach is given in Figure 7.13.

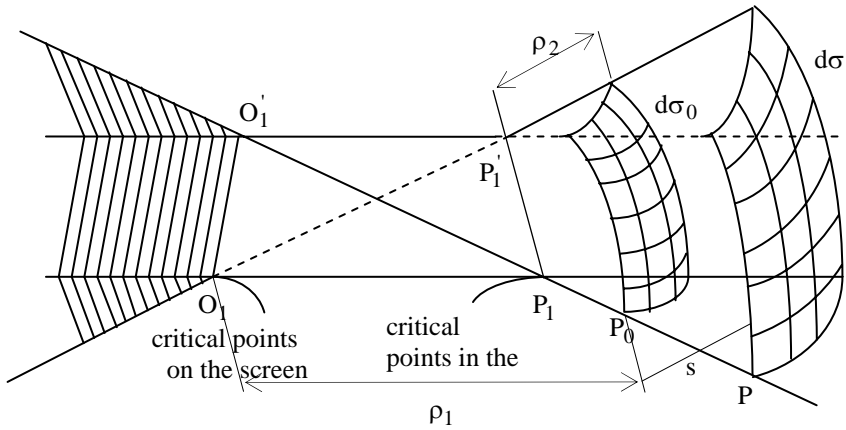

**Figure 7.13.** Elementary tubes of energy (notations):  $O_1$  and  $O_1'$  are the critical points on the edge of the screen,  $P_1$  and  $P_1'$  are those in the space of diffraction

The radii of curvature of the elementary straight sections whose wavefronts are separated by a distance  $s$  are respectively  $\rho_1$ ,  $\rho_2$  and  $\rho_1 + s$ ,  $\rho_2 + s$ . As the acoustic intensity at each point is proportional to the square of the amplitude  $A$  of the wave at the same point, the energy flow conservation can be written as

$$A_s^2 d\sigma = A_0^2 d\sigma_0, \tag{7.63}$$

( $A_s$  and  $A_0$  denote, respectively, the amplitudes at the surfaces  $d\sigma$  and  $d\sigma_0$ )

$$\text{thus, } A_s = A_0 \left[ \frac{\rho_1 \rho_2}{(\rho_1 + s)(\rho_2 + s)} \right]^{1/2}, \tag{7.64}$$

$$\text{or } A_0 \sqrt{\rho_2} = A_s \left[ \frac{(\rho_1 + s)(\rho_2 + s)}{\rho_1} \right]^{1/2}. \tag{7.65}$$

The quantity  $\rho_1$  will now denote the distance between the first caustic formed by the diffracting edge and the second caustic of the diffracted rays. The distance  $\rho_2$  tends to zero and, since the right-hand side term of equation (7.65) does not vanish, the limit of the first term is different of zero. This leads to

$$A_0' = \lim_{\rho_2 \rightarrow 0} A_0 \sqrt{\rho_2} = \left[ \frac{(\rho_1 + s)s}{\rho_1} \right]^{1/2} A_s, \tag{7.66}$$

and consequently, the amplitude  $A_s$  of the field at the point P is

$$A_s = A_0' \left[ \frac{\rho_1}{(\rho_1 + s)s} \right]^{1/2}. \quad (7.67)$$

Note: if the considered point is located on one of the caustics ( $\rho_1 + s = 0$  or  $s = 0$ ), the amplitude  $A_s$  tends to infinity. The geometric theory of Keller is not appropriate when calculating the acoustic field on the caustics and in their immediate vicinity.

### 7.2.7.3. Expression of the field associated to a ray

The diffracted acoustic field can be written as

$$\Phi = A_s e^{-i(ks + \psi_0)}, \quad (7.68)$$

where the complex amplitude factor  $A_0' e^{-i\psi_0}$  remains to be determined. The method proposed by Keller is based on taking the origin of the field on the diffracting element and writing the diffracted field as proportional to the incident field  $A_i e^{-i\psi_i}$ . The coefficient of proportionality (called diffraction coefficient) can be a complex number:

$$A_0' e^{-i\psi_0} = D A_i e^{-i\psi_i}, \quad (7.69)$$

where the diffraction coefficient is denoted  $D$ . Thus, according to equations (7.67), (7.68), and (7.69), the expression of the diffracted acoustic field becomes

$$\Phi(s) = D A_i e^{-i\psi_i} \frac{e^{-iks}}{\sqrt{(1 + s/\rho_1)s}}. \quad (7.70)$$

The expression (7.70) introduces a product of the following four factors: the diffraction coefficient  $D$ , the incident field at the diffracting element  $A_i e^{-i\psi_i}$ , the phase factor  $e^{-iks}$ , and the amplitude term depending on the distance  $\rho_1$  between the caustic induced by the diffracting edge and the second caustic created by the diffracted rays. Note that the analysis of the wavefronts properties leads to the estimation of  $\rho_1$  when the profile of the edge and nature of the incident wave are known.

The diffraction coefficient  $D$  is yet an unknown. This coefficient can only be obtained from the known solutions to the problems of diffraction. For example, the comparison of the above result for the diffraction of a plane wave by a straight edge



( $\rho_1 \rightarrow \infty$ , cylindrical field) with the asymptotic result obtained using the theory of Sommerfeld (equation (7.41) for a far field in the region III), gives directly (with  $A = A_1 e^{-i\psi_1}$ )

$$D = \frac{1+i}{4\sqrt{\pi k}} \left[ \frac{G(\psi + \varphi/2)}{\sin(\psi + \varphi/2)} - \frac{G(\varphi/2)}{\cos(\varphi/2)} \right]. \quad (7.71)$$

The asymptotic field corresponding to finite values of  $\rho_1$  exhibits spherical characteristics.

Keller's diffraction theory is of interest since it allows one to treat the problems of diffraction by a screen on a reflecting plane (i.e. floor) while considering the presence of walls (vertical walls, ceilings, etc.), all based on the notions of sources and receiving images.

Note 1: Rubinowicz divided the integral expression of  $p(\vec{r})$  in Kirchoff's theory into two terms. The first term represents the direct wave (null in the "shadowed" region) and the second term represents the wave diffracted by the edge of the screen. The second term is expressed as a curvilinear integral over the contour made by the edge of the aperture  $A$  in the screen.

Note 2: Huygens' principle easily explains that the diffraction by an object with a curved surface is described by a phenomenon of "sliding" of the waves along the surface ("creeping" waves) and which propagate continuously into the rest of the considered space (diffracted waves: Figure 7.14).

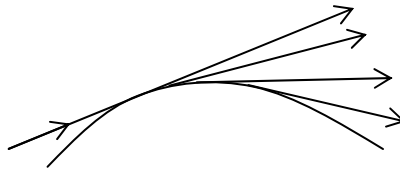

**Figure 7.14.** "Creeping" waves at the surface of an object and diffracted wave

Note 3: when the rays converge in a particular region of space (Figure 7.15), there is focalization of the acoustic field characterized by very high amplitudes. The surface delimiting the volume containing all these rays is called "caustic". This region appears as a "boundary" layer within which the energy transfers occur not only in the direction of the rays, following the classical quasi-adiabatic process, but also in a plane perpendicular to the rays, by transverse diffusion, proportional to the transverse gradients of the pressure field (great at these points).

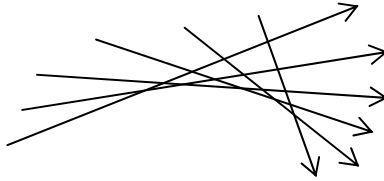

**Figure 7.15.** *Creation of a caustic*

### 7.3. Acoustic propagation in non-homogeneous and non-dissipative media in motion, varying “slowly” in time and space: geometric approximation

#### 7.3.1. Introduction

A plane wave is characterized by its constant direction of propagation and amplitude in the entire space. In practice, sound waves do not present such properties. However, a non-plane wave can, in some conditions, be considered as plane within small regions of the considered space. For such approximation to be made, the variation of the amplitude and direction propagation over a distance roughly equal to the wavelength must be very small.

These conditions are fulfilled in media qualified as “slowly varying in time and space” and defined by a scale of characteristic length  $L_c \approx \rho_E / |\bar{\nabla} \rho_E|$  and characteristic time  $T_c \approx \rho_E / (\partial \rho_E / \partial t)$  of the medium, which are much greater than the wavelength  $\lambda$  and period  $T$  of the wave:

$$\lambda \ll L_c \text{ and } T \ll T_c,$$

$\rho_E$  denoting the density of the medium in the absence of acoustic perturbation.

The domain of application of this approach, called “geometric method”, is vast. It includes the problems of radiation, diffraction, and noise propagation in atmosphere and buildings, as well as the problems of flows in tubes and diffusers, jet engines, air conditioning systems, etc. The strength of this method is based on simple integrations of ordinary differential equations.

The objective of the following section is to give examples of the application of this method while keeping a sense of generality for the sake of completeness of the discussion.

Finding a geometric solution is done in three steps. First, one needs to determine the dispersion relation of the medium governing the trajectory of the rays. The

equation can then be solved – here the solution is given for two simple, but important, cases. Finally, the amplitude of the acoustic field is calculated using an equation that generally takes the form of an equation of conservation (the problem of spatial distribution of the energy is not discussed here).

### 7.3.2. Fundamental equations

When outside the region of influence of any source, the mass conservation law (1.28), the impulse conservation law (Euler's equation (1.32)) and the entropy conservation law (1.34) for a non-dissipative, non-homogeneous and flowing fluid (fluid not at rest) can be written as follows:

$$\frac{\partial}{\partial t} \rho_T + \operatorname{div}(\rho_T \vec{v}_T) = 0, \quad (7.72a)$$

$$\frac{\partial}{\partial t} \vec{v}_T + \vec{v}_T \cdot \operatorname{grad} \vec{v}_T + \frac{1}{\rho_T} \operatorname{grad} p_T = \vec{0}, \quad (7.72b)$$

$$\frac{d}{dt} \sigma_T = \frac{\partial}{\partial t} \sigma_T + \vec{v}_T \cdot \operatorname{grad} \sigma_T = 0, \quad (7.72c)$$

where  $\sigma_T = S_T / C_V$  is the “dimensionless” entropy per unit mass and where the parameters  $p_T$ ,  $\rho_T$  and  $\vec{v}_T$  denote the pressure, density and velocity. The subscript “T” marks the quantities describing the complete motion of the fluid.

If the fluid is assumed bivalent (its state is determined by two thermodynamic variables), its state equation is

$$p_T = f(\rho_T, \sigma_T). \quad (7.73)$$

The phenomenon is described as the superposition of a flow phenomenon to an acoustic phenomenon which are functions of the point considered at any given time:

$$\begin{aligned} p_T &= p_E + p, \\ \rho_T &= \rho_E + \rho, \\ \vec{v}_T &= \vec{v}_E + \vec{v}, \\ \sigma_T &= \sigma_E + \sigma, \end{aligned} \quad (7.74)$$

where the subscript “E” marks the non-stationary mean quantities of the non-acoustic motion and the quantities  $p$ ,  $\rho$ ,  $\vec{v}$  and  $\sigma$  are associated with the acoustic perturbation (and therefore are small). The notation  $\rho$  replaces here the notation  $\rho'$  used elsewhere in this book.

At the order zero of the quantities (7.74), equations (7.72) and (7.73) become

$$\frac{\partial}{\partial t} \rho_E + \operatorname{div}(\rho_E \bar{v}_E) = 0, \quad (7.75a)$$

$$\frac{\partial}{\partial t} \bar{v}_E + \bar{v}_E \cdot \operatorname{grad} \bar{v}_E + \frac{1}{\rho_E} \operatorname{grad} p_E = \bar{0}, \quad (7.75b)$$

$$\frac{\partial}{\partial t} \sigma_E + \bar{v}_E \cdot \operatorname{grad} \sigma_E = 0, \quad (7.75c)$$

$$p_E = f(\rho_E, \sigma_E). \quad (7.75d)$$

For the equations governing the acoustic perturbation, the quantities must be taken at the first order, thus

$$\frac{\partial}{\partial t} \rho + \bar{v}_E \cdot \operatorname{grad} \rho + \bar{v}_E \cdot \operatorname{grad} \rho_E + \rho_E \operatorname{div} \bar{v} + \rho \operatorname{div} \bar{v}_E = 0, \quad (7.76a)$$

$$\frac{\partial}{\partial t} \bar{v} + \bar{v}_E \cdot \operatorname{grad} \bar{v}_E + \bar{v}_E \cdot \operatorname{grad} \bar{v} + \frac{1}{\rho_E} \operatorname{grad} p - \frac{\rho}{\rho_E^2} \operatorname{grad} p_E = \bar{0}, \quad (7.76b)$$

$$\frac{\partial}{\partial t} \sigma + \bar{v}_E \cdot \operatorname{grad} \sigma_E + \bar{v}_E \cdot \operatorname{grad} \sigma = 0, \quad (7.76c)$$

$$p = \left[ \frac{\partial p_E}{\partial \rho_E} \right]_{\sigma_E} \rho + \left[ \frac{\partial p_E}{\partial \sigma_E} \right]_{\rho_E} \sigma = c_E^2 \rho + \pi_E \sigma. \quad (7.76d)$$

The substitution of equation (1.23)

$$(dT_E)_{\rho_E} = \frac{1}{p_E \beta} (dp_E)_{\rho_E}$$

into equation (1.21)

$$C_v (d\sigma_E)_{\rho_E} = \left[ \frac{C_p}{T_E} \frac{1}{p_E \beta} - \frac{C_p - C_v}{T_E p_E \beta} \right] (dp_E)_{\rho_E}$$

leads immediately, for a perfect gas ( $\beta = 1/T_E$ ), to

$$\pi_E = p_E. \quad (7.77a)$$

Also, the adiabatic speed of sound for a perfect gas is given by

$$c_E^2 = \gamma p_E / \rho_E. \quad (7.77b)$$

The variable  $\rho$  is first replaced in equations (7.76a) and (7.76b) by its expression obtained from equation (7.76d); the acoustic quantities on which are applied differential operators are then regrouped in the right-hand side terms. Thus, equations (7.76) become:

$$\left( \frac{\partial}{\partial t} + \vec{v}_E \cdot \text{grad} \right) p + \rho_E c_E^2 \text{div } \vec{v} = 0_1^E, \quad (7.78a)$$

$$\text{with } 0_1^E = -(p - \pi_E \sigma) \left[ c_E^2 \left( \frac{\partial}{\partial t} + \vec{v}_E \cdot \text{grad} \right) \frac{1}{c_E^2} + \text{div } \vec{v}_E \right] \\ - \pi_E \vec{v} \cdot \text{grad } \sigma_E - c_E^2 \vec{v} \cdot \text{grad } \rho_E$$

$$\left( \frac{\partial}{\partial t} + \vec{v}_E \cdot \text{grad} \right) \vec{v} + \frac{1}{\rho_E} \text{grad } p = \vec{0}_2^E, \quad (7.78b)$$

$$\text{with } \vec{0}_2^E = -\vec{v} \cdot \text{grad } \vec{v}_E + (p - \pi_E \sigma) \rho_E^{-2} c_E^{-2} \text{grad } p_E,$$

$$\left( \frac{\partial}{\partial t} + \vec{v}_E \cdot \text{grad} \right) \sigma = -\vec{v} \cdot \text{grad } \sigma_E. \quad (7.78c)$$

### 7.3.3. Modes of perturbation

According to the hypothesis made in the introduction (media with characteristics varying in time and space), the solution to the system of equations (7.78) can, *a priori*, be sought in the form

$$\begin{bmatrix} p \\ \vec{v} \\ \sigma \end{bmatrix} = \begin{bmatrix} p_A(\vec{r}, t) \\ \vec{v}_A(\vec{r}, t) \\ \sigma_A(\vec{r}, t) \end{bmatrix} e^{i\psi(\vec{r}, t)}. \quad (7.79)$$

The real amplitude, noted by subscript “A”, are functions which slowly vary in space and time, and the phase  $\psi$  is a real function of  $\vec{r}$  and  $t$ , given by

$$\psi = \psi_0 + \vec{r} \cdot \text{grad } \psi + \frac{\partial \psi}{\partial t} t, \quad (7.80)$$

where  $\text{grad } \psi$  and  $\partial \psi / \partial t$  are also slowly varying functions of the space and time coordinates and where  $\psi_0$  is defined by the phase initial condition. Assuming that within small spaces (relative to the wavelength) and within small periods of time (relative to the period) the wave can be considered as a, it is then possible to define a local propagation vector and a local frequency:

$$\vec{k}(\vec{r}, t) = -\text{grad } \psi \quad \text{and} \quad \omega(\vec{r}, t) = \partial \psi / \partial t. \quad (7.81)$$

The quantity  $\psi$  is called “eikonal” or “iconal”.

By considering that

$$\frac{\partial}{\partial t} e^{i\psi} = \left( i\omega + it \frac{\partial}{\partial t} \omega - i\vec{r} \cdot \frac{\partial}{\partial t} \vec{k} \right) e^{i\psi}$$

and  $\text{grad } e^{i\psi} = (-i\vec{k} - ix_j \text{grad } k_j + it \text{grad } \omega) e^{i\psi}$  (sum over all values of  $j$ ), equations (7.78) can be written regrouping the terms in  $\omega$  and  $\vec{k}$  in the left-hand side, and the spatial and time partial derivatives of amplitudes, propagation vector and frequencies in the right-hand side (including  $0_1^E$ ):

$$\begin{bmatrix} i(\omega - \vec{k} \cdot \vec{v}_E) & -i\rho_E c_E^2 \vec{k} & 0 \\ -i\rho_E^{-1} \vec{k} & i(\omega - \vec{k} \cdot \vec{v}_E) & 0 \\ 0 & 0 & +i(\omega - \vec{k} \cdot \vec{v}_E) \end{bmatrix} \begin{bmatrix} p_A \\ \vec{v}_A \\ \sigma_A \end{bmatrix} = \begin{bmatrix} A \\ \vec{B} \\ C \end{bmatrix}. \quad (7.82)$$

Written as a matrix equation, this system becomes

$$[\mathbf{H}][\mathbf{Q}_A] = [\mathbf{F}]. \quad (7.83)$$

Since the medium is assumed to be slowly varying in space and time, the spatial and time derivative of the quantities  $c_E$ ,  $\vec{v}_E$ ,  $\rho_E$ ,  $\vec{k}$  and  $\omega$  are small and the order of magnitude of these variations are characterized by an infinitely small  $\varepsilon = O(\lambda/L_c, T/T_c)$ . Consequently, expanding at the order zero the system (7.83) gives

$$[\mathbf{H}] \left[ \mathbf{Q}_A^{(0)} \right] = \mathbf{0}, \quad (7.84)$$

and at the first order:

$$[\mathbf{H}]\left[\mathbf{Q}_A^{(1)}\right] = \left[\mathbf{F}^{(0)}\right],$$

and at the  $n^{\text{th}}$  order:

$$[\mathbf{H}]\left[\mathbf{Q}_A^{(n)}\right] = \left[\mathbf{F}^{(n-1)}\right], \quad (7.85)$$

where  $\left[\mathbf{F}^{(n-1)}\right]$  denotes the non-homogeneous term obtained by substituting the solutions  $\left[\mathbf{Q}_A^{(n)}\right]$  obtained at the  $(n-1)^{\text{th}}$  order.

This “hierarchy” of system only has solutions if the system at the order zero (7.84) has itself a non-trivial solution, in other words if the determinant of the matrix  $[\mathbf{H}]$  is null. This condition is satisfied by setting the following dispersion relation to the acoustic perturbations:

$$(\omega - \vec{k} \cdot \vec{v}_E) [(\omega - \vec{k} \cdot \vec{v}_E)^2 - k^2 c_E^2] = 0. \quad (7.86)$$

Equation (7.86) has two kinds of solutions with which are associated two particular kinds of motions: vortical and entropic modes on the one hand, and acoustic modes on the other hand:

i) The vortical and entropic modes are characterized by the eigenvalue  $\omega = \vec{k} \cdot \vec{v}_E$  of the dispersion relation (7.86). These are the modes convected by the flow. The substitution of this equation into equation (7.84), and denoting  $p_0$ ,  $\vec{v}_0$  and  $\sigma_0$  the corresponding solutions lead to

$$\begin{bmatrix} 0 & -i\rho_E c_E^2 \vec{k} & 0 \\ -i\rho_E^{-1} \vec{k} & 0 & 0 \\ 0 & 0 & 0 \end{bmatrix} \begin{bmatrix} p_0 \\ \vec{v}_0 \\ \sigma_0 \end{bmatrix} = 0. \quad (7.87)$$

The solutions to the matrix equation lead to the definition of the following modes:

– the vortical mode characterized by:

$$- \vec{k} \cdot \vec{v}_0 = 0, \text{ or } \vec{v}_0 \text{ perpendicular to } \vec{k}, \quad (7.88a)$$

$$- \text{and } \vec{k} p_0 = \vec{0} \Rightarrow p_0 = 0, \quad (7.88b)$$

– the entropic mode corresponding to either

$$- \sigma_0 \neq 0 \text{ or } \sigma_0 = 0. \quad (7.89)$$

These motions are not presented in section 7.3.

ii) The acoustic modes are characterized by the double solution to the following dispersion relation:

$$(\omega - \vec{k} \cdot \vec{v}_E)^2 = k^2 c_E^2. \quad (7.90)$$

Substituted into equations (7.74), equation (7.90) leads, on the one hand, to  $\sigma_0 = 0$  (isentropic modes) and, on the other hand, to:

$$\vec{k} p_0 = \rho_E (\omega - \vec{k} \cdot \vec{v}_E) \vec{v}_0. \quad (7.91)$$

The dispersion relation  $(\omega - \vec{k} \cdot \vec{v}_E)^2 = k^2 c_E^2$  has two solutions:

$$\pm \left( \frac{\omega}{c_E} - \vec{k} \cdot \hat{\vec{k}} \frac{\vec{v}_E}{c_E} \right) = k \text{ where } \hat{\vec{k}} = \vec{k} / |\vec{k}|,$$

$$\text{thus } k (1 \pm \hat{\vec{k}} \cdot \vec{M}) = \pm \frac{\omega}{c_E} \text{ or } k_{\pm} = \frac{\pm \omega / c_E}{1 \pm \hat{\vec{k}}_{\pm} \cdot \vec{M}}, \quad (7.92)$$

where  $\vec{M} = \vec{v}_E / c_E$  is the Mach's vector ( $M < 1$ ) and  $\hat{\vec{k}}_{\pm} = \vec{k}_{\pm} / |\vec{k}_{\pm}|$  is the unit vector associated with the propagation vector  $\vec{k}$ .

The solution  $\vec{k}_+$ , for example, must verify the dispersion relation for any given relative orientation of  $\vec{k}_+$  and  $\vec{M}$ . For each of these relative orientations, a solution  $\vec{k}_- = -\vec{k}_+$  exists, coinciding with the solution  $\vec{k}_+$  the orientation of which is at  $180^\circ$  with the initial orientation (regardless of the orientation of  $\vec{k}_+$  and  $\vec{M}$ ). Consequently, conserving only one solution does not affect the generality of the problem. By considering the solution  $\vec{k}_+$ , the dispersion relation that will be used here is

$$\omega - \vec{k} \cdot \vec{v}_E = k c_E. \quad (7.93)$$

The solution to this equation that is, according to (7.81), nothing other than a non-linear partial differential equation of the first order applied to  $\vec{\psi}(\vec{r}, t)$  leads to the variation of the phase in space and time. The equations of acoustic rays are obtained following this approach in the next section.



### 7.3.4. Equations of rays

The equations of rays are obtained by solving equation (7.93) written as

$$\omega = kc_E + \vec{k} \cdot \vec{v}_E, \tag{7.94}$$

that can also be written, in a more general form, as

$$\omega(\vec{r}, t) = \Omega(\vec{k}, \vec{r}, t), \tag{7.95}$$

where the function  $\Omega$  depends on three variables: the variable  $\vec{k}$  associated with the acoustic wave, and the variables  $\vec{r}$  and  $t$  on which depend the characteristic quantities of the medium in motion  $c_E$  and  $\vec{v}_E$ .

By virtue of definition (equation (7.81)), the quantities

$$\omega = \frac{\partial \psi}{\partial t} \tag{7.96}$$

$$\text{and } \vec{k} = -\text{grad } \psi \tag{7.97}$$

are closely related to the evolution of the field along a ray.

In order to generalize the approach, the following equations are derived from equation (7.95) and only then will the particular case of  $\Omega$  defined by equation (7.94) be explicitly presented.

#### 7.3.4.1. Preliminary calculus

For the sake of simplicity, the operator  $\partial/\partial t$ ,  $\text{grad}$  over the variable  $\vec{r}$  and  $\text{grad}$  over the variable  $\vec{k}$ , will be denoted as  $\partial_t$ ,  $\partial_{\vec{r}}$  and  $\partial_{\vec{k}}$  respectively.

##### 7.3.4.1.1. Derivation of $\partial_t \omega$

$$\partial_t \omega = \partial_t \Omega + \partial_{\vec{k}} \Omega \cdot \partial_t \vec{k}, \tag{7.98}$$

$$\Rightarrow \partial_t \omega = \partial_t \Omega + \vec{c}_g \cdot \partial_t \vec{k}, \tag{7.99}$$

where by definition  $\vec{c}_g = \partial_{\vec{k}} \Omega$  with, for  $\Omega = kc_E + \vec{k} \cdot \vec{v}_E$ ,

$$\partial_t \Omega = k \partial_t c_E + \vec{k} \cdot \partial_t \vec{v}_E, \tag{7.100}$$

$$\partial_{\vec{k}} \Omega = \vec{c}_g = c_E \frac{\vec{k}}{k} + \vec{v}_E \text{ (Figure 7.16)}. \tag{7.101}$$

7.3.4.1.2. Derivation of  $\partial_{\vec{r}}\omega$ 

$$\text{grad}_{\vec{r}}\omega = \partial_{\vec{r}}\omega = \partial_{\vec{r}}\Omega + \partial_{\vec{k}}\Omega \cdot \partial_{\vec{r}}\vec{k}, \quad (7.102)$$

$$\text{where } \partial_{\vec{k}}\Omega \cdot \partial_{\vec{r}}\vec{k} = \sum_i \partial_{k_i}\Omega \vec{\nabla}k_i,$$

with, for  $\Omega = kc_E + \vec{k} \cdot \vec{\nabla}_E$ ,

$$\partial_{\vec{r}}\Omega = k \partial_{\vec{r}}c_E + \vec{k} \cdot \partial_{\vec{r}}\vec{\nabla}_E. \quad (7.103)$$

## 7.3.4.2. Equation of rays

Equations (7.96) and (7.97) immediately give

$$\partial_t \vec{k} + \text{grad} \omega = \vec{0}, \quad (7.104)$$

$$\text{curl} \vec{k} = \vec{0}. \quad (7.105)$$

The substitution of equation (7.95) leads to the  $i^{\text{th}}$  component of equation (7.104):

$$\partial_t k_i + \partial_{k_j}\Omega \partial_{x_i} k_j + \partial_{x_i}\Omega = 0,$$

or, considering that  $\partial_{x_i} k_j = \partial_{x_j} k_i$  since  $\text{curl} \vec{k} = \vec{0}$ ,

$$\partial_t \vec{k} + \partial_{k_j}\Omega \partial_{x_j} \vec{k} = -\partial_{\vec{r}}\Omega.$$

Finally, according to (7.99):

$$(\partial_t + \vec{c}_g \cdot \text{grad}) \vec{k} = -\text{grad} \Omega. \quad (7.106)$$

By defining the operator “material derivative”

$$d_t^{c_E} = \partial_t + \vec{c}_g \cdot \text{grad}, \quad (7.107)$$

equation (7.106) becomes

$$d_t^{c_E} \vec{k} = -\text{grad} \Omega, \quad (7.108)$$

and, for  $\Omega = kc_E + \vec{k} \cdot \vec{\nabla}_E$ ,

$$d_t^{c_E} \vec{k} = -k \text{grad } c_E - k_j \text{grad } v_{Ej}. \tag{7.109}$$

This is the equation of rays.

7.3.4.3. Interpretation of the operator  $d_t^{c_E}$  and speed  $\vec{c}_g$

The operator  $d_t^{c_E}$  applied to the phase  $\psi$  of a wave gives, according to equations (7.99) and (7.81):

$$d_t^{c_E} \psi = \partial_t \psi + \vec{c}_g \cdot \text{grad } \psi = \Omega - \partial_{\vec{k}}(\Omega) \vec{k}, \tag{7.110}$$

thus, for  $\Omega = kc_E + \vec{k} \cdot \vec{v}_E$  and considering equation (7.94),

$$d_t^{c_E} \psi = \omega - \left( c_E \frac{\vec{k}}{k} + \vec{v}_E \right) \cdot \vec{k} = \omega - (c_E k + \vec{k} \cdot \vec{v}_E) = 0. \tag{7.111}$$

Consequently, along the trajectory defined by the speed  $\vec{c}_g$ , the phase  $\psi$  of the wave is invariant. Moreover, the relation

$$d_t^{c_E} \vec{r} = \partial_t \vec{r} + \vec{c}_g \cdot \partial_{\vec{r}} \vec{r} = \vec{c}_g \tag{7.112}$$

determines the speed of propagation of the wave. This speed of propagation is given by the expression (7.101) of  $\vec{c}_g$  showing that it is the geometric projection of the speed  $c$  on the direction of  $\vec{k}$  and velocity  $\vec{v}_E$  of the fluid flow (Figure 7.16).

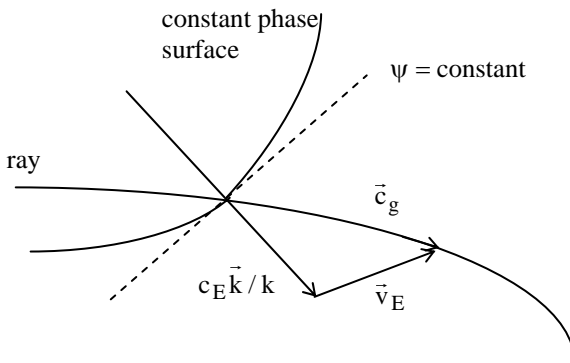

Figure 7.16. Speed of propagation (from equation (7.101))

Therefore, the speed  $\bar{c}_g$  represents the speed of propagation of the waves along the characteristic trajectory (ray), and the operator  $d_t^{c_E}$  represents the material derivative taken along this acoustic trajectory.

#### 7.3.4.4. Wave frequency

Since the speed of the wave and the speed of the non-acoustic flow are functions of the time (the medium depending on the time) in general, the frequency of the wave is also a function of the observation point and time. The equation satisfied by this function is obtained by writing (according to (7.107)) that

$$d_t^{c_E} \omega = (\partial_t + \bar{c}_g \cdot \text{grad}) \omega,$$

or, according to (7.99) and (7.102), that

$$d_t^{c_E} \omega = (\partial_t \Omega + \partial_{\bar{k}} \Omega \cdot \partial_t \bar{k}) + \partial_{\bar{k}} \Omega \cdot \left[ \partial_{\bar{r}} \Omega + \partial_{\bar{k}} \Omega \cdot \partial_{\bar{r}} \bar{k} \right],$$

or, according to (7.107), that

$$d_t^{c_E} \omega = \partial_t \Omega + \partial_{\bar{k}} \Omega \cdot \left[ \partial_{\bar{r}} \Omega + d_t^{c_E} \bar{k} \right].$$

According to (7.108), the term in brackets is null, thus

$$d_t^{c_E} \omega = \partial_t \Omega. \quad (7.113)$$

In the particular case where  $\Omega = kc_E + \bar{k} \cdot \bar{v}_E$ , the substitution of equation (7.100) into (7.113) gives:

$$d_t^{c_E} \omega = k \partial_t c_E + \bar{k} \cdot \partial_t \bar{v}_E. \quad (7.114)$$

Note: if the “mean medium” is independent of the time,  $\partial_t c_E = 0$  and  $\partial_t \bar{v}_E = \vec{0}$ , the wave remains at the same frequency along a ray. Similarly, equation (7.109) shows that if  $\text{grad} c_E$  and  $\text{grad} \bar{v}_E$  are null, the wavenumber  $\bar{k}$  is constant along the ray.

#### 7.3.4.5. Summary of the results

By solving the iconal equation (7.94)

$$\omega = kc_E + \bar{k} \cdot \bar{v}_E$$

written in its general form

$$\omega = \Omega(\vec{r}, \vec{k}, t),$$

or, according to (7.96) and (7.97), as

$$\partial_t \psi - \Omega(\vec{r}, \text{grad } \psi, t) = 0, \tag{7.115}$$

is reduced to the integration of the following characteristic system of equations:

$$d_t^{c_E} \vec{r} = \partial_{\vec{k}} \Omega = \vec{c}_g \text{ according to (7.101) and (7.112),} \tag{7.116a}$$

$$d_t^{c_E} \vec{k} = -\partial_{\vec{r}} \Omega \text{ according to (7.108),} \tag{7.116b}$$

$$d_t^{c_E} \omega = \partial_t \Omega \text{ according to (7.113),} \tag{7.116c}$$

$$d_t^{c_E} \psi = \Omega - \partial_{\vec{k}} \Omega \cdot \vec{k} \text{ according to (7.110).} \tag{7.116d}$$

One can note here that if  $\Omega$  is considered as a Hamiltonian operator, equations (7.116a) and (7.116b) are then Hamilton's equations.

In case the dispersion relation is that given by equation (7.94) ( $\omega = kc_E + \vec{k} \cdot \vec{v}_E$ ), this system can be written, according to equations (7.101), (7.109), (7.114) and (7.111), as:

$$d_t^{c_E} \vec{r} = \frac{\vec{k}}{k} c_E + \vec{v}_E = \vec{c}_g, \tag{7.117a}$$

$$d_t^{c_E} \vec{k} = -k \text{ grad } c_E - k_j \text{ grad } v_{Ej} = -k \text{ grad } c_E - (\vec{k} \cdot \text{grad}) \vec{v}_E - \vec{k} \wedge \text{curl } \vec{v}_E, \tag{7.117b}$$

$$d_t^{c_E} \omega = k \partial_t c_E + \vec{k} \cdot \partial_t \vec{v}_E, \tag{7.117c}$$

$$d_t^{c_E} \psi = 0. \tag{7.117d}$$

The two first equations lead to the tracing of the ray. Knowing the vector  $\vec{k}$  at a given point  $\vec{r}$  (at the source for example), equations (7.117a) and (7.117b) gives the position of the point of the ray located at the distance  $|\text{d}\vec{r}|$  and the variation  $\text{d}\vec{k}$  of the vector  $\vec{k}$  during the period of time  $\text{d}t$ . Thus, by iteration, the ray can be traced.

Note: these equations are often written using Mach's vector  $\vec{M} = \vec{v}_E / c_E$  and the subscript  $v = c_0 / c_E$ .

### 7.3.5. Applications to simple cases

#### 7.3.5.1. Motionless mean medium quasi-homogeneous and time invariant

##### 7.3.5.1.1. Frequency

Equation (7.117c) gives

$$d_t^{c_0} \omega = \partial_t \Omega = k \partial_t c_0 + \vec{k} \cdot \partial_t \vec{v}_E = 0$$

where the speed  $c_E(\vec{r}, t)$  is here  $c_0(\vec{r})$ .

The frequency is a constant to an observer following the trajectory along a ray.

##### 7.3.5.1.2. Equation of rays

According to the previous result and since  $\vec{v}_E = \vec{0}$ , the first equation (7.117b) can be written as

$$d_t^{c_0} \left( \frac{\omega}{c_0} \vec{n} \right) = -k \text{grad} c_0,$$

where  $\vec{n} = \vec{k}/k$ , thus

$$\frac{\vec{n}}{c_0} d_t^{c_0} \omega + \vec{n} \omega d_t^{c_0} \left( \frac{1}{c_0} \right) + \frac{\omega}{c_0} d_t^{c_0} \vec{n} = -k \text{grad} c_0. \quad (7.118)$$

The left-hand side terms of this equation satisfy the following conditions (see next section):

$$d_t^{c_0} \omega = 0,$$

$$d_t^{c_0} \left( \frac{1}{c_0} \right) = \partial_t \left( \frac{1}{c_0} \right) + \vec{c}_g \cdot \text{grad} \left( \frac{1}{c_0} \right) = -\frac{\vec{n}}{c_0} \cdot \text{grad} c_0,$$

since  $\partial_t \left( \frac{1}{c_0} \right) = 0$  (time invariant medium) and  $\vec{c}_g = c_0 \vec{n}$  ( $\vec{v}_E = \vec{0}$ ),

$$\frac{1}{c_0} d_t^{c_0} (\vec{n}) = \frac{1}{c_g} \frac{d^{c_0} \vec{n}}{dt} = \frac{d\vec{n}}{d\ell} = d_\ell \vec{n}$$

where  $d\ell$  denotes the length of a trajectory element of the trajectory of a ray,  $k = \omega/c_0$  (since  $\vec{v}_E = \vec{0}$ ).

Since  $\vec{n} \cdot \vec{n} = 1$  and  $d_\ell(\vec{n} \cdot \vec{n}) = 2\vec{n} \cdot d_\ell \vec{n} = 0$ , equation (7.119) becomes

$$d_\ell \vec{n} = \left( \frac{\vec{n}}{c_0} \cdot \text{grad } c_0 \right) \vec{n} - \frac{1}{c_0} \text{grad } c_0. \tag{7.119}$$

This shows that  $d_\ell \vec{n}$  and  $\vec{n}$  are orthogonal vectors. Consequently, a direction perpendicular to the trajectory ( $\vec{N}$ ) and a radius of curvature ( $R$ ) can be defined by

$$\frac{|d\vec{n}|}{|\vec{n}|} = \frac{d\ell}{R} \quad (\text{Figure 7.17}) \quad \text{or by} \tag{7.120}$$

$$d_\ell \vec{n} = \vec{N} / R.$$

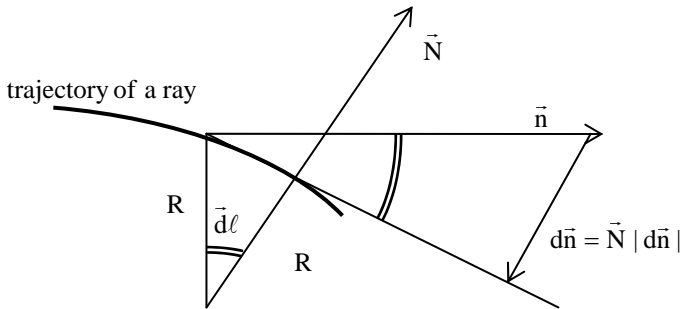

**Figure 7.17.** Radius of curvature of a ray

Equation (7.119) can also be written as

$$\frac{\vec{N}}{R} = \left( \frac{\vec{n}}{c_0} \cdot \text{grad } c_0 \right) \vec{n} - \frac{1}{c_0} \text{grad } c_0.$$

The above equation shows that the vector represented by a double line in Figure 7.18 is  $\vec{N}/R$ . From this result, one can conclude that the curvature of a ray is in the same direction as the decreasing direction of the speed of sound. Moreover, the scalar product of this equation with the unit vector  $\vec{N}$  leads to:

$$\frac{1}{R} = -\frac{\vec{N}}{c_0} \cdot \text{grad } c_0. \tag{7.121}$$

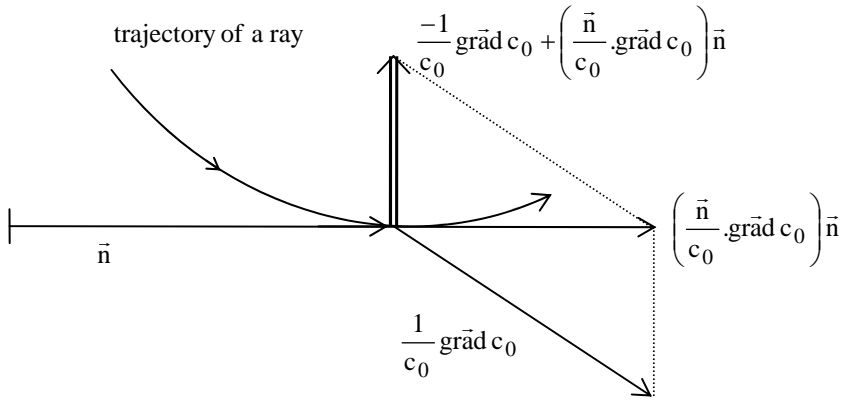

**Figure 7.18.** Curvature of a ray

Equation (7.121) can be obtained directly by applying Fermat’s principle, proof of which is given in section 7.3.6.

Note: the orientation of the curvature of the ray shows that the trajectory tends to pass through the layers of “high” speed of sound, to join the two points belonging to the regions of lower speed of sound. This is in accordance with Fermat’s principle (minimizing the propagation time). In the case of propagation in the air at the vicinity of the ground during seasons with high temperatures, a temperature gradient (thus a gradient of speed of sound that is proportional to the latter by  $c_0^2 = \gamma RT/M$  with  $R$  being the constant of perfect gases,  $M$  the molar mass and  $T$  the absolute temperature) occurs above the ground. The rays then present the profiles given in Figure 7.19.

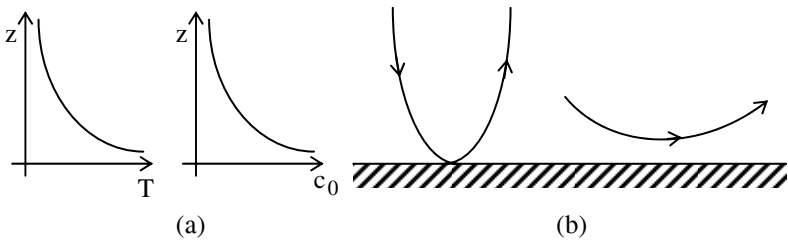

**Figure 7.19.** Ray traces (b) for a given profile of temperature and associated profile of celerity (a)



7.3.5.2. *Quasi-homogeneous mean media in stationary motion*

The considered medium is independent of the observation point and is time invariant ( $\rho_E$  and  $c_E$  are constants). The medium is in stationary motion with the velocity  $\vec{v}_E$  which is a function of the point considered but time invariant. The variations of this velocity are considered significant only over distances much greater than the wavelength, the associated Mach number ( $v_E / c_E$ ) remaining much smaller than one.

The substitution of the equation  $\vec{k} = k\vec{n}$  (definition of  $\vec{n}$ ) into equation (7.177b) leads to the following equation:

$$\vec{n} d_t^{c_E} k + k d_t^{c_E} \vec{n} = -(\vec{k} \cdot \text{grad}) \vec{v}_E - \vec{k} \wedge \text{curl} \vec{v}_E. \quad (7.122)$$

The scalar product of equation (7.122) by  $\vec{n}$ , considering the fact that  $d_t^{c_E}(\vec{n} \cdot \vec{n}) = d_t^{c_E}(1) = 0 = 2\vec{n} \cdot d_t^{c_E} \vec{n}$  gives

$$d_t^{c_E} k = -\vec{n} \cdot (\vec{k} \cdot \text{grad}) \vec{v}_E. \quad (7.123)$$

Equation (7.123) highlights the fact that  $d_t^{c_E} k$  and, consequently,  $k d_t^{c_E} \vec{n}$  (see equation (7.122)) are of the same order of magnitude as the spatial variations  $v_E / c_E$ . Thus, the approximation (7.101) where  $v_E \ll c_E$ ,

$$\frac{\vec{c}_g}{c_E} = \vec{n} + \frac{\vec{v}_E}{c_E} \approx \vec{n} = \vec{k} / k,$$

is valid and can be used in the operator  $d_t^{c_E}$ , then written as

$$d_t^{c_E} \approx \frac{c_E}{c_g} d_t^{c_E} = c_E \frac{d}{d\ell}, \quad (7.124a)$$

where, by definition,  $d\ell$  denotes the length of a trajectory element. Moreover, according to equation (7.94),

$$d_t^{c_E}(\vec{k}) = d_t^{c_E} \left( \frac{\omega}{c_E + \vec{n} \cdot \vec{v}_E} \right),$$

or, since by hypothesis  $d_t^{c_E} \omega = 0$  (7.117c) and the medium being assumed (quasi-) homogeneous

$$d_t^{c_E} k = \omega d_t^{c_E} \left( \frac{1}{c_E + \vec{n} \cdot \vec{v}_E} \right) \approx \omega d_t^{c_E} \left( \frac{1}{c_E} \right) = 0. \quad (7.124b)$$

This result implies, according to equation (7.123) and to the fact that the orientations of  $\vec{n}$  and  $\vec{v}_E$  are independent, that

$$(\vec{k} \cdot \text{grad}) \vec{v}_E \approx \vec{0}. \quad (7.124c)$$

The substitution of the three equations (7.124) into equation (7.122) gives

$$d_\ell \vec{n} \approx \frac{1}{c_E} \text{curl} \vec{v}_E \wedge \vec{n}. \quad (7.125)$$

Note: the equation  $d_t^{c_E} \omega = 0$  implies that  $\omega$  is a constant from an observation point following the trajectory at the speed  $c_E$ .

*Example of application: wind above the ground (Figure 7.20)*

The effect of the wind on the acoustic propagation is considered here in the particular case where the velocity of the air is parallel to the ground, mono-directional (along the  $\vec{Ox}$  axis) and is monotonous increasing in the positive  $z$  direction, in other words equal to zero at  $z = 0$  (ground level):

$$\vec{v}_E = V(z) \vec{u}_x,$$

where  $\vec{u}_x$  denotes the unit vector of the  $\vec{Ox}$  axis.

Equation (7.125) takes the following form:

$$\frac{dn_x}{d\ell} = \frac{n_z}{c_E} \frac{\partial V}{\partial z}, \quad (7.126a)$$

$$\frac{dn_y}{d\ell} = 0, \quad (7.126b)$$

$$\frac{dn_z}{d\ell} = -\frac{n_x}{c_E} \frac{\partial V}{\partial z}. \quad (7.126c)$$

The directing cosines governing the direction of radiation at ground level ( $z = 0$ ) are denoted  $n_{x_0}$ ,  $n_{y_0}$  and  $n_{z_0}$  (Figure 7.20a). Equation (7.126b) gives

$$n_y = n_{y_0} = \text{constant}.$$

Consequently, by choosing the  $(x, z)$ -plane perpendicular to the  $\vec{Oy}$  axis,  $dz/d\ell = n_z/n = n_z$  and equation (7.126a) becomes

$$\frac{dn_x}{d\ell} = \frac{1}{c_E} \frac{\partial V}{\partial z} \frac{dz}{d\ell} = \frac{1}{c_E} \frac{\partial V}{\partial \ell}.$$

Finally, when considering the conditions at  $x = 0$ ,

$$n_x = n_{x_0} + \frac{V(z)}{c_E}. \quad (7.127)$$

Since  $\vec{n}$  is a unit vector,

$$n_z^2 = 1 - n_x^2 = 1 - \left[ n_{x_0} + \frac{V(z)}{c_E} \right]^2. \quad (7.128)$$

The derivative with respect to  $\ell$  of equation (7.128) leads successively to:

$$2n_z \frac{dn_z}{d\ell} = -2 \left( n_{x_0} + \frac{V}{c_E} \right) \frac{1}{c_E} \frac{dV}{dz} \frac{dz}{d\ell},$$

$$\text{or } \frac{dn_z}{d\ell} = - \frac{n_{x_0} + \frac{V}{c_E}}{c_E n_z} \frac{dV}{dz} n_z = - \frac{n_x}{c_E} \frac{dV}{dz}.$$

This is nothing other than equation (7.126c) that is, according to (7.128), satisfied by the solution (7.127). This set of equations (7.127) and (7.128) is then the solution to the system of equations (7.126a, b and c).

The rays can only reach a limited finite height ( $z_{\max}$ ) for  $n_z = 0$ . In other words when (equation (9.128))

$$V(z_{\max}) = c_E(1 - n_{x_0}). \quad (7.129)$$

The sign used for the solution is in accordance with the hypothesis that  $V(z) > 0$ .

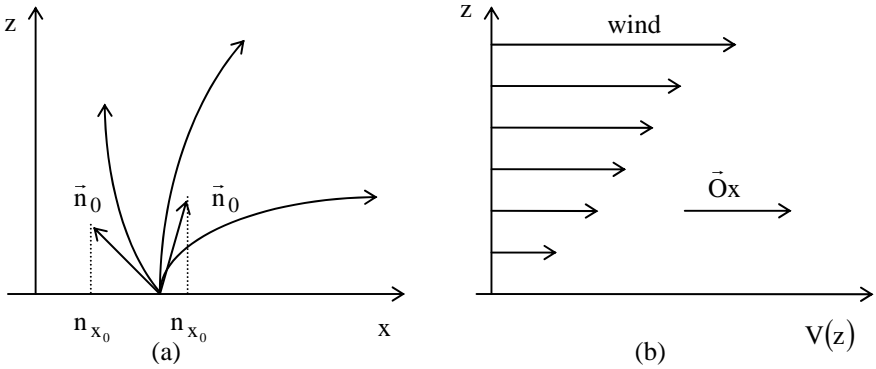

**Figure 7.20.** Effect of a vertical gradient of wind (b) on the trajectory of rays (a)

**7.3.6. Fermat’s principle**

Equation (7.121) can also be obtained applying Fermat’s principle. This principle postulates that the time taken by a wave to travel between two points (A and B) is minimal. If  $v$  denotes the index of the medium which is the ration of the minimal speed  $c_m$  to the speed  $c_0$  of the medium ( $v = c_m/c_0$ ) as the only quantity responsible for the perturbation, this principle can be expressed by writing that the variation  $\delta I$  of the optic path (integral of the elementary optic path between the two points A and B) is equal to zero:

$$\delta I = \delta \int_A^B v d\ell = 0, \tag{7.130}$$

where the operator “ $\delta$ ” represents the infinitesimal geometric variation of the admissible path and  $d\ell$  denotes the element of length of the trajectory (Figure 7.21).

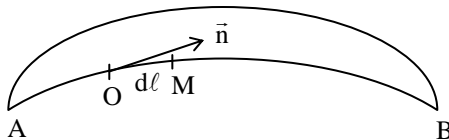

**Figure 7.21.** Real trajectory AOB and neighboring trajectory (operator “ $\delta$ ”)

Equation (7.130) can also be written as

$$\delta I = \int_A^B v \delta(d\ell) + \int_A^B \text{grad } v \cdot \delta \vec{OM} d\ell.$$

The first integral can be modified, noting that

$$\begin{aligned} \delta(d\ell) &= \delta\sqrt{(d\vec{O}\vec{M})^2} = \frac{d\vec{O}\vec{M} \cdot \delta(d\vec{O}\vec{M})}{\sqrt{(d\vec{O}\vec{M})^2}} = \delta(d\vec{O}\vec{M}) \cdot \frac{d\vec{O}\vec{M}}{d\ell}, \\ &= \delta(d\vec{O}\vec{M}) \cdot \vec{n} = \vec{n} \cdot d(\vec{O}\vec{M}), \end{aligned}$$

where  $\vec{n}$  denotes the unit vector tangent to the ray (admissible path). Thus

$$\begin{aligned} \int_A^B v \delta(d\ell) &= \int_A^B v \vec{n} \cdot d(\vec{O}\vec{M}) = \int_A^B v \vec{n} \cdot \frac{d(\vec{O}\vec{M})}{d\ell} d\ell, \\ &= \left[ v \vec{n} \cdot \vec{O}\vec{M} \right]_A^B - \int_A^B \frac{d(v \vec{n})}{d\ell} d\ell \cdot \vec{O}\vec{M} = - \int_A^B \frac{d(v \vec{n})}{d\ell} \cdot \vec{O}\vec{M} d\ell, \end{aligned}$$

since the factor  $\left[ v \vec{n} \cdot \vec{O}\vec{M} \right]_A^B$  is null as  $\delta A = \delta B = 0$  (by hypothesis).

Therefore, equation (7.130) becomes:

$$\begin{aligned} \delta I &= \int_A^B \left[ \text{grad} v - \frac{d(v \vec{n})}{d\ell} \right] \cdot \vec{O}\vec{M} d\ell = 0, \quad \forall A, B \\ \text{thus } \frac{d(v \vec{n})}{d\ell} &= \text{grad} v = - \frac{v}{c_0} \text{grad} c_0. \end{aligned} \tag{7.131}$$

The first term of this equation can also be written, according to (7.120), as

$$\frac{d(v \vec{n})}{d\ell} = \frac{dv}{d\ell} \vec{n} + v \frac{\vec{N}}{R},$$

so that the scalar product of this new form with the unit vector  $\vec{N}$ , perpendicular to the trajectory, is

$$\vec{N} \cdot \frac{d(v \vec{n})}{d\ell} = 0 + \frac{v}{R} = \frac{v}{R}.$$

The substitution of this result into equation (7.131) finally gives

$$\frac{1}{R} = - \vec{N} \cdot \frac{\text{grad} c_0}{c_0}. \tag{7.132}$$

This equation is nothing other than equation (7.121).

### 7.3.7. Equation of parabolic waves

The equation of propagation in a non-homogeneous medium of which properties are time invariant, but remain spatially dependent functions (varying “slowly” in space) for a harmonic wave, takes the form of Helmholtz equation (1.45):

$$\left( \Delta + \frac{\omega^2}{c^2} \right) p(\vec{r}) = 0, \quad (7.133)$$

where the speed  $c$  depends on the coordinates of the considered point. Making the hypothesis that the medium is quasi-homogeneous (with a small gradient), the speed of sound can be written as

$$c = c_0 \left[ 1 - \frac{1}{2} \varepsilon(\vec{r}) \right], \quad (7.134)$$

where  $c_0$  is here a constant, so that equation (7.133) becomes

$$\left( \Delta + \frac{\omega^2}{c_0^2} [1 + \varepsilon(\vec{r})] \right) p(\vec{r}) = 0. \quad (7.135)$$

The absence of an analytical method to solve such an equation has motivated numerous works, especially in ionosphere and sub-marine propagation aimed at a parabolic reduced form of equation (7.135):

– assuming an additional hypothesis according to which the propagation is limited to waves traveling within a “channel” in a given direction, chosen as the axis of reference ( $\vec{Oz}$  in the following), leading to a solution of the form

$$p(\vec{r}) = P(\vec{r}) e^{ik_0 z}, \text{ with } k_0 = \omega / c_0,$$

– assuming that the variations in the  $z$ -direction of the amplitude  $P(\vec{w}, z)$  are significantly slower than those of the function  $e^{ik_0 z}$ , consequently that

$$\left| \frac{\partial^2 P}{\partial z^2} \right| \ll \left| 2ik_0 \frac{\partial P}{\partial z} \right|, \quad (7.136)$$

and finally equation (7.135) takes the following parabolic approximate form

$$\left[ \Delta_{\vec{w}} + 2ik_0 \frac{\partial}{\partial z} + \varepsilon(\vec{r}) k_0^2 \right] P(\vec{r}) = 0, \quad (7.137)$$

which is a typical Schrödinger's equation

$$\left[ \frac{\hbar^2}{2m} \Delta_{\vec{w}} + i\hbar \frac{\partial}{\partial t} - U \right] \psi = 0 \quad (7.138)$$

where  $m = 1$ ,  $\hbar = 1/k_0$  and  $U = -\varepsilon/2$ .

An analogous approach to the one adopted at the beginning of section 7.3, valid outside the points of energy concentration (caustics), leads to an eikonal equation on the phase of the amplitude  $P(\vec{r})$  from which the equations of the trajectories can be obtained as Hamilton's equations, analogous to (7.116a) and (7.116b). At the vicinity of the caustic regions, other forms of solutions must be considered.

In cylindrical geometry, for a symmetrical propagation with respect to a given axis, the Helmholtz equation (7.135) becomes

$$\left( \frac{1}{r} \frac{\partial}{\partial r} \left( r \frac{\partial}{\partial r} \right) + \frac{\partial^2}{\partial z^2} + \frac{\omega^2}{c_0^2} [1 + \varepsilon(r, z)] \right) p(r, z) = 0. \quad (7.139)$$

In numerous real situations, the variable  $r$  is chosen as the horizontal coordinate while  $z$  is chosen as the vertical coordinate (height and depth), the propagation being often considered along the variable  $r$  and the medium characteristics varying generally with respect to the variable  $z$ . Thus, the solution is

$$p(r, z) = \frac{1}{\sqrt{r}} P(r, z) e^{ik_0 r}. \quad (7.140)$$

The substitution of equation (7.140) into equation (7.139) gives

$$\left[ \frac{1}{4r^2} + \frac{\partial^2}{\partial r^2} + 2ik_0 \frac{\partial}{\partial r} + \frac{\partial^2}{\partial z^2} + k_0^2 \varepsilon(z) \right] P(r, z) = 0. \quad (7.141)$$

The far field propagation (great value of  $r$ ) is the most often considered case while the spatial variation of  $P$  (along  $r$ ) is often assumed to be slow

$$\left| \frac{\partial^2 P}{\partial r^2} \right| \ll \left| 2ik_0 \frac{\partial P}{\partial r} \right|. \quad (7.142)$$

Thus, equation (7.141) is simplified and becomes

$$\left[ 2ik_0 \frac{\partial}{\partial r} + \frac{\partial^2}{\partial z^2} + k_0^2 \varepsilon(z) \right] P(r, z) = 0. \quad (7.143)$$

The solution sought can be taken in the form of a Fourier transform

$$P(r, z) = \int A(r, z, q_z, k_0) e^{ik_0[q_r r + q_z z - \Phi(q_z)]} dq_z, \quad (7.144)$$

leading, at the lowest order (only the factor without derivative of A), to the following iconal equation:

$$q_z^2 + 2q_r - \varepsilon = 0. \quad (7.145)$$

It can be deduced from equation (7.145): the characteristic equations that are analogous to (7.116a) and (7.116b) as well as the highest order acoustic solutions as it was done for the solutions of the system of equations (7.84) and (7.85).

The objective of this section is to briefly present an area of study that is still under investigation.



*This page intentionally left blank*

## Chapter 8

# Introduction to Sound Radiation and Transparency of Walls

This chapter deals with the transmission of sound energy through walls and with the various types of coupling associated with it. The hypothesis of harmonic waves, even plane waves, will often be adopted for the sake of simplicity and clarity. For similar reasons, the medium surrounding the structure will be assumed non-dissipative (the index “0” used in the previous chapter on the quantities  $\rho$ ,  $c$  and  $k$  is not used in this chapter). The object of this chapter is to apply the methods introduced in the previous chapters to the problem of sound transmission through walls.

### **8.1. Waves in membranes and plates**

The focus here is on the problem of transparencies of elastic walls and subsequently on the problem of vibrations of plates and membranes, thin or thick, under acoustic load. The vibration motion of such structures is predominantly in the direction perpendicular to the mid-plane of the structure considered. To fully understand the process of sound transmission through walls, it is important to first introduce the various mechanical waves induced in elastic structures by incident sound fields. The bulk of this chapter then introduces the methods to treat a wide range of situations. The chapter starts with a brief introduction to the principal types of waves encountered in membranes and plates and the associated wave equations.

**8.1.1. Longitudinal and quasi-longitudinal waves**

The direction of propagation of longitudinal waves coincides with the direction of the particle displacement (Figure 1.2). The phenomenon of longitudinal wave propagation in a solid is similar in many aspects to that of plane waves in fluids, in essence because the phenomenon results from compression type motions. Longitudinal waves are encountered in many vibrating structures such as junctions (“T” for example) and are widely used when measuring material characteristics. For the sake of simplicity, the equation of propagation of a longitudinal wave propagating in one direction will be derived.

In a “one-dimensional” plate (beam), the propagation of a longitudinal wave results in translations of the planes perpendicular to the main axis of the structure. Figure 8.1 shows the respective translations of two parallel planes initially at rest and located respectively at  $z$  and  $z + dz$ .

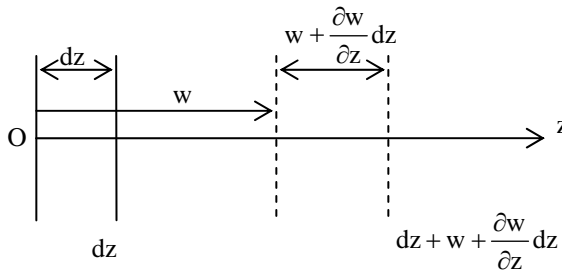

**Figure 8.1.** Longitudinal waves in a one-dimensional solid

As the translations are not necessarily equal for both planes, the propagation of a longitudinal wave induces a strain  $\epsilon_{zz}$  equal to  $\frac{\partial w}{\partial z}$ . The associated stress  $\sigma_{zz}$  is given by Hooke’s law as proportional to  $\epsilon_{zz}$  (assuming the magnitude of the displacement is small). Complete analysis of this proportionality shows that the ratio of longitudinal stress to longitudinal strain is given by

$$\sigma_{zz} = B_L \frac{\partial w}{\partial z} = \frac{E(1-\nu)}{(1+\nu)(1-2\nu)} \frac{\partial w}{\partial z}, \tag{8.1}$$

where  $\nu$  denotes the Poisson’s ratio and  $E$  the Young’s modulus of the material considered. The resulting equation of propagation is obtained writing the equality between the force acting on the element with the mass of the element multiplied by its acceleration. If one denotes the cross-sectional area  $S$  and the density  $\rho$

$$(\rho S dz) \frac{\partial^2 w}{\partial t^2} = \left[ \sigma_{zz} + \frac{\partial \sigma_{zz}}{\partial z} dz - \sigma_{zz} \right] S = \frac{\partial \sigma_{zz}}{\partial z} dz S. \quad (8.2)$$

The substitution of equation (8.1) into (8.2) gives

$$\frac{\partial^2 w}{\partial z^2} - \frac{\rho}{B_L} \frac{\partial^2 w}{\partial t^2} = 0. \quad (8.3)$$

The longitudinal phase velocity is then given by

$$c_L = \sqrt{\frac{B_L}{\rho}}. \quad (8.4)$$

The phase velocity is independent of the frequency of the wave and, consequently, longitudinal waves are non-dispersive.

It is qualitatively simple to see that pure longitudinal waves can only occur in solids, the dimensions of which are far greater than the considered wavelengths. However, longitudinal waves still occur in most structures, regardless of their dimensions, as compression waves resulting in a motion in the axis of the beam as well as in a contraction of the cross-sectional area. These are called “quasi-longitudinal waves”.

In the particular case of longitudinal waves in a thin plate, according to the theory of elasticity (not presented herein), a relationship between the tension and the longitudinal distortion of a plate element is well established

$$\sigma_{zz} = \frac{E}{1-\nu^2} \frac{\partial w}{\partial z}, \quad (8.5)$$

leading to a corresponding equation of propagation equivalent to equation (8.3)

$$\frac{\partial^2 w}{\partial x^2} - \frac{\rho(1-\nu^2)}{E} \frac{\partial^2 w}{\partial t^2} = 0, \quad (8.6)$$

and to the phase velocity of quasi-longitudinal wave

$$c_L = \sqrt{\frac{E}{\rho(1-\nu^2)}}. \quad (8.7)$$

Longitudinal waves do not induce displacements in the direction normal to the direction of propagation and are therefore not considered as the predominant waves in radiation problems. In practice, structures are often more complex than simple plates, and beams are often used as connectors between other components. Longitudinal waves can play a vital role in the vibration transmission through discontinuities in the structures, such as junctions, by conversion of the longitudinal displacements into transverse displacements that are more radiation efficient, and vice versa. This aspect of vibration transmission is beyond the scope of this book.

**8.1.2. Transverse shear waves**

Unlike fluids and gases, solids tend to resist static and dynamic shear deformations. Transverse waves are characterized by a vibration displacement perpendicular to the direction of propagation of the wave, pure shear waves being a perfect example of transverse waves (Figure 1.1).

When a rectangular solid element is under pure shear forces (Figure 8.2), the shear stresses generated tend to oppose the deformation in the direction of the shear forces. In static equilibrium, the shear stresses  $\tau_{xy}$  and  $\tau_{yx}$  on both sides of the solid element considered are equal and opposite. The solid tends to limit the deformation efficiently. In dynamic situations, however, when a shear wave is traveling through the same solid element in the  $x$  direction, the difference of shear stresses is not necessarily zero, resulting in a difference of displacement  $\frac{\partial \eta}{\partial x} dx$  in the direction of the stresses (similar to that seen for longitudinal waves).

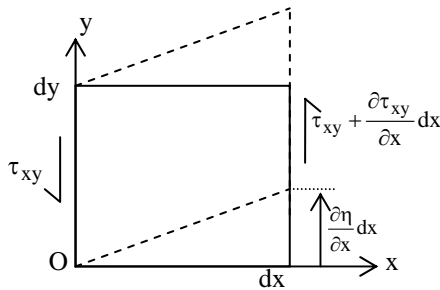

**Figure 8.2.** *Transverse shear stresses and displacement in pure shear deformation*

The assumption of small displacements is made and, *a fortiori*, justified since the domain of application implies a necessarily small displacement within the limits of linear acoustics. The shear stresses are proportional to the shear strain and the coefficient of proportionality  $G$  is

$$G = \frac{E}{2(1+\nu)}. \quad (8.8)$$

The equation of motion in the  $y$ -direction of the solid element of unit thickness and cross-sectional area  $dx dy$  is

$$\rho \frac{\partial^2 \eta}{\partial t^2} dx dy = \frac{\partial^2 \tau_{xy}}{\partial x^2} dx dy. \quad (8.9)$$

The substitution of equation (8.8) into (8.9) gives the equation of propagation of transverse shear waves,

$$\frac{\partial^2 \eta}{\partial x^2} - \frac{\rho}{G} \frac{\partial^2 \eta}{\partial t^2} = 0, \quad (8.10)$$

and the phase velocity of shear waves,

$$c_s = \sqrt{\frac{G}{\rho}}. \quad (8.11)$$

Once again the phase velocity is independent of the frequency and, consequently, shear waves are non-dispersive. The effects of shear deformation can contribute significantly to the vibrational state of a structure, particularly for laminated plates made of dynamically different laminae. Also, as for longitudinal waves, the energy propagated by shear waves is partly converted into flexural wave energy (and vice versa) at junctions in complex structures.

### 8.1.3. Flexural waves

#### 8.1.3.1. Generally

Flexural waves (also called bending waves) in beams and plates are characterized by a motion perpendicular to the direction of propagation and to the surface of the structure. While longitudinal waves are associated with a local change of volume and transverse waves with a local change of shape, flexural waves are associated with both. They are therefore predominant in sound radiation from

structure since this type of motion is highly compatible with typical fluid particle motions, but also because acoustic loading (of any incidence) generates easily flexural waves.

Unlike the two other types of waves previously presented, bending waves are represented by four variables: the transverse velocity of a solid element; the angular velocity about the axis perpendicular to the plane of the structure; the bending moment acting at a cross-section of the solid about the same axis; and the shear forces transmitted to the adjacent solid element.

The well-known representation of bending displacements and deformation is given in Figure 8.3.

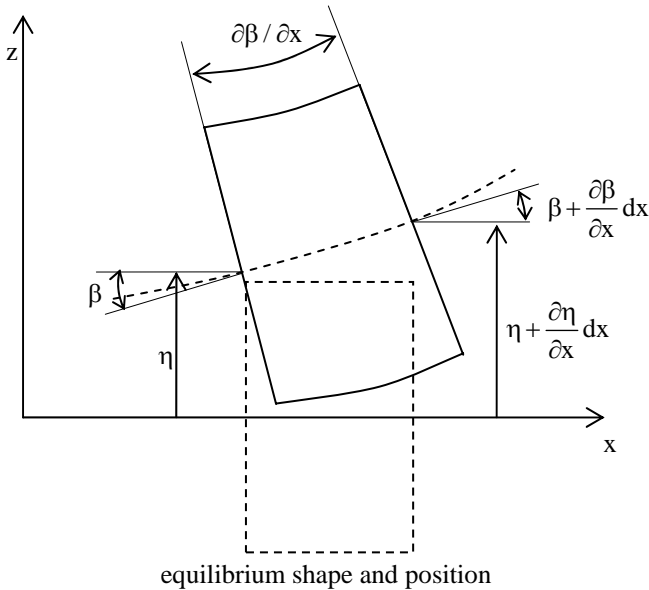

**Figure 8.3.** Displacement and deformation of a beam element in bending

### 8.1.3.2. Flexural waves in membranes

Membranes are assumed thin and uniform with negligible thickness, and perfectly elastic so that the rigidity is governed by the tension of the membrane  $T$  (per unit of length). The tension applied at the edges of the membrane (by a rim for example) is defined so that an element of length  $dx$  is under the tensile force  $Tdx$ .

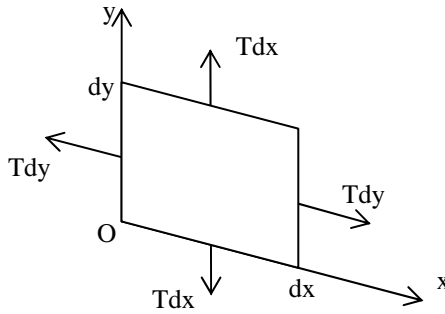

**Figure 8.4.** Membrane with null thickness under tension

The total force acting on a surface element  $dS$  of the membrane is the sum of the transverse forces acting on the edges parallel to the  $x$ - and  $y$ -directions, which are respectively:

$$Tdy \left[ \left( \frac{\partial z}{\partial x} \right)_{x+dx} - \left( \frac{\partial z}{\partial x} \right)_x \right] = T \frac{\partial^2 z}{\partial x^2} dx dy, \quad (8.12a)$$

$$Tdx \left[ \left( \frac{\partial z}{\partial y} \right)_{y+dy} - \left( \frac{\partial z}{\partial y} \right)_y \right] = T \frac{\partial^2 z}{\partial y^2} dx dy. \quad (8.12b)$$

Applying Newton's second law on a membrane element  $dx dy$  of mass per unit area  $M_s$  and of acceleration  $\partial^2 z / \partial t^2$  gives

$$T \left( \frac{\partial^2 z}{\partial x^2} + \frac{\partial^2 z}{\partial y^2} \right) dx dy - M_s \frac{\partial^2 z}{\partial t^2} dx dy = 0, \quad (8.13)$$

and finally

$$\frac{\partial^2 z}{\partial x^2} + \frac{\partial^2 z}{\partial y^2} - \frac{M_s}{T} \frac{\partial^2 z}{\partial t^2} = 0. \quad (8.14)$$

The corresponding phase velocity of flexural waves in a membrane is

$$c_T = \sqrt{\frac{T}{M_s}}. \quad (8.15)$$



8.1.3.3. Flexural waves in plates

In the following section, the plate is assumed isotropic. The notation convention for moments of pure flexural waves in thin plates are given in Figure 8.5.

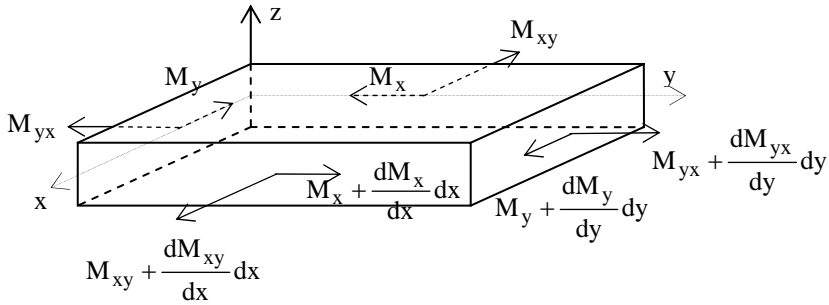

Figure 8.5. Moments acting on a plate element

The directions and notations for the stresses applied to a thin plate element are given in Figure 8.6 where the notation  $\tau$  is used for the shear stresses and  $\sigma$  for the normal stresses.

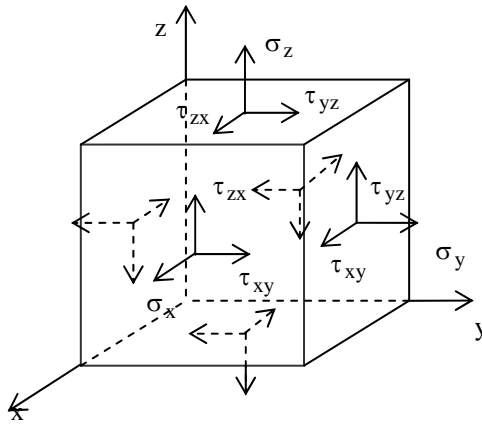

Figure 8.6. Notations and positive directions of stresses in a thin plate element

According to Figure 8.6, the bending moments acting on the plate element are:

$$\begin{aligned}
 M_x &= \int_{-h/2}^{h/2} \sigma_{xx} z dz, \\
 M_y &= \int_{-h/2}^{h/2} \sigma_{yy} z dz, \\
 M_{xy} &= M_{yx} = \int_{-h/2}^{h/2} \sigma_{xy} z dz.
 \end{aligned}
 \tag{8.16}$$

The in-plane strains and shear strains are related to the plate displacement field  $\left( \xi_x = -z \frac{\partial w}{\partial x}, \xi_y = -z \frac{\partial w}{\partial y}, w \right)$ :

$$\begin{aligned}\varepsilon_{xx} &= \frac{\partial \xi_x}{\partial x}, \\ \varepsilon_{yy} &= \frac{\partial \xi_y}{\partial y}, \\ \varepsilon_{xy} &= \frac{\partial \xi_y}{\partial x} + \frac{\partial \xi_x}{\partial y}.\end{aligned}\tag{8.17}$$

The associated stresses for an isotropic plate are related to the strains by Hooke's law where the coefficients of proportionality are obvious

$$\begin{aligned}\sigma_{xx} &= \frac{E}{1-\nu^2} (\varepsilon_{xx} + \nu \varepsilon_{yy}), \\ \sigma_{yy} &= \frac{E}{1-\nu^2} (\varepsilon_{yy} + \nu \varepsilon_{xx}), \\ \sigma_{xy} &= G \varepsilon_{xy}.\end{aligned}\tag{8.18}$$

By replacing the in-plane displacements components with their expressions as functions of the transverse component into equation (8.17) gives the expressions of the stresses in the plate as functions of the transverse displacement. The resulting equations can then be substituted into equations (8.16), leading to

$$\begin{aligned}M_x &= -B \left( \frac{\partial^2 w}{\partial x^2} + \nu \frac{\partial^2 w}{\partial y^2} \right), \\ M_y &= -B \left( \nu \frac{\partial^2 w}{\partial x^2} + \frac{\partial^2 w}{\partial y^2} \right), \\ M_{xy} = M_{yx} &= -B(1-\nu) \frac{\partial^2 w}{\partial x \partial y},\end{aligned}\tag{8.19}$$

where B denotes the bending stiffness of the plate and is equal to  $\frac{Eh^3}{12(1-\nu^2)}$  where h denotes the thickness of the plate.

The total forces applied onto the plate element resulting from these moments are then given by

$$\begin{aligned} Q_x &= -B \left( \frac{\partial^3 w}{\partial x^3} + \frac{\partial^3 w}{\partial x \partial y^2} \right), \\ Q_y &= -B \left( \frac{\partial^3 w}{\partial x^2 \partial y} + \frac{\partial^3 w}{\partial y^3} \right). \end{aligned} \quad (8.20)$$

In the z-direction, Newton's second law gives

$$\frac{\partial Q_x}{\partial x} + \frac{\partial Q_y}{\partial y} = M_s \frac{\partial^2 w}{\partial t^2}. \quad (8.21)$$

The substitution of equation (8.20) into (8.21) gives the equation of propagation of flexural waves in a thin plate

$$B \Delta^2 w + M_s \frac{\partial^2 w}{\partial t^2} = 0, \quad (8.22)$$

where  $\Delta^2$  denotes the double Laplacian  $\left( \frac{\partial^2}{\partial x^2} + \frac{\partial^2}{\partial y^2} \right)^2$ .

The associated frequency dependent flexural waves phase velocity is directly obtained from equation (8.22) as

$$c_f = \left( \frac{B}{M_s} \right)^{1/4} \sqrt{\omega}. \quad (8.23)$$

Flexural waves are therefore dispersive as the flexural waves phase velocity depends on the frequency.

## 8.2. Governing equation for thin, plane, homogeneous and isotropic plate in transverse motion

The following section presents the equations of motion for thin, plane, homogeneous and isotropic plates, and briefly introduces a few important notions. It is a reminder of the laws governing the motion of membranes and plates.

### 8.2.1. Equation of motion of membranes

Under the action of a transverse force applied on the surface by, for example, an acoustic pressure  $P(\vec{r}, t)$  exerted onto the plate, the transverse displacement  $w$  of a membrane ( $S$ ), of negligible thickness, is a solution to the non-homogeneous equation of propagation (8.14)

$$T\Delta w - M_s \frac{\partial^2 w}{\partial t^2} = -P(\vec{r}, t) \text{ over } (S), \quad (8.24)$$

where  $M_s$  denotes the mass per unit area of the membrane and  $T$  its tension.

With this equation is associated initial and boundary conditions. The most commonly-used boundary conditions are Sommerfeld's for an infinite membrane and Dirichlet's (applied to the perimeter  $\mathcal{C}$ ) for finite membranes (i.e. membrane stretched by a rigid frame).

The "structural" damping of the membrane due to friction forces within the material can be introduced as a friction force per unit area  $R \partial w / \partial t$  in the equation of propagation.

In the case of a harmonically-excited membrane in a rigid frame, assuming separable geometry, the solution can be expanded in the basis of eigenfunctions. The resulting eigenvalue problem is

$$(\Delta + k_{mn}^2) \psi_{mn} = 0 \text{ over } (S), \quad (8.25a)$$

$$\psi_{mn} = 0 \text{ on } (\mathcal{C}), \quad (8.25b)$$

$$\text{with } k_{mn}^2 = \omega_{mn}^2 (M_s / T). \quad (8.25c)$$

For a rectangular membrane of length  $a$  and width  $b$ , the most suitable origin of the coordinate system is in one of the corners of the membrane. If Dirichlet's

conditions are fulfilled (no displacement on the perimeter) the ortho-normal eigenfunctions and associated eigenvalues are respectively given by

$$\psi_{mn} = \frac{2}{\sqrt{ab}} \sin\left(\frac{m\pi x}{a}\right) \sin\left(\frac{n\pi y}{b}\right), \tag{8.26a}$$

$$k_{mn} = \left[ \left(\frac{m\pi}{a}\right)^2 + \left(\frac{n\pi}{b}\right)^2 \right]^{1/2}. \tag{8.26b}$$

For a circular membrane of radius  $a$  in the same conditions (the origin is at the centre of the membrane), the eigenfunctions are

$$\psi_{mn} = \frac{1}{\sqrt{(1 + \delta_{m0})\pi}} \begin{bmatrix} \cos \\ \sin \end{bmatrix} (m\varphi) \frac{\sqrt{2}}{a J'_m(k_{mn}a)} J_m(k_{mn}r), \tag{8.27a}$$

and the eigenvalues are solutions to

$$J_m(k_{mn}a) = 0. \tag{8.27b}$$

In both cases, the orthogonality of the eigenfunctions is expressed by

$$\iint_S \psi_{mn} \psi_{qr} dS = \delta_{mq} \delta_{nr}. \tag{8.28}$$

### 8.2.2. Thin, homogeneous and isotropic plates in pure bending

#### 8.2.2.1. Governing equation

Under a pressure load  $P(\vec{r}, t)$ , the displacement  $w$  of an elastic thin plate (homogeneous and isotropic) is a solution to the non-homogeneous equation of propagation (8.22):

$$B \Delta^2 w + M_s \frac{\partial^2 w}{\partial t^2} = P(\vec{r}, t), \text{ over } (S), \tag{8.29}$$

where  $B = Eh^3 / 12(1 - \nu^2)$  and  $\Delta^2$  denote, respectively, the bending stiffness of the material and the double Laplacian.

Sommerfeld's boundary conditions are often adopted for infinite plates. In the case of plates of finite dimensions, simple and analytical solutions are readily

available only for simple supports boundary conditions which are therefore the most suitable to this presentation.

The structural damping of the plate corresponds to an energy dissipation associated with various types of frictions within the material. In harmonic regime, the dissipative force is proportional to the elastic force and, *a fortiori*, to the relative displacement. Consequently, this type of damping can be introduced in the governing equations replacing the bending stiffness  $B$  by a complex  $\bar{B} = B(1 + i\eta)$  or directly introducing in the governing equation the term  $R \partial w / \partial t$  (as was done for membranes). The first choice is equivalent to considering a complex Young's modulus (Voigt's model). In both cases, the frictional term is only an approximation of the reality.

### 8.2.2.2. General solution to the governing homogeneous equation

By adopting the hypothesis that the vibrations are free (harmonic motion and no external load), the eigenvalues problem associated with the equation of propagation (8.29) is

$$\left(\Delta^2 - \beta^4\right)w = 0, \quad (8.30)$$

where  $\beta^4 = \omega^2 M_s / B$

and can also be written as

$$\left(\Delta + \beta^2\right)\left(\Delta - \beta^2\right)w = 0. \quad (8.31)$$

The general solution to equation (8.31) is given by

$$w = w_+ + w_-, \quad (8.32)$$

where the functions  $w_{\pm}$  satisfy the following equations:

$$\left(\Delta \pm \beta^2\right)w_{\pm} = 0. \quad (8.33)$$

The solutions to this type of equations are the exponential functions:

$$w_+ = e^{\pm i\alpha x} e^{\pm i\gamma y}, \quad (8.34a)$$

$$w_- = e^{\pm \alpha x} e^{\pm \gamma y}, \quad (8.34b)$$

$$\text{with, in both cases, } \alpha^2 + \gamma^2 = \beta^2. \quad (8.34c)$$

The general solution can then be written as the sum of eight products of exponential functions (real or complex) or as eight products of hyperbolic or trigonometric functions:

$$\begin{aligned}
 w(x, y) = & A_1 \sin(\alpha x) \sin(\gamma y) + A_2 \sin(\alpha x) \cos(\gamma y) \\
 & + A_3 \cos(\alpha x) \sin(\gamma y) + A_4 \cos(\alpha x) \cos(\gamma y) \\
 & + A_5 \sinh(\alpha x) \sinh(\gamma y) + A_6 \sinh(\alpha x) \cosh(\gamma y) \\
 & + A_7 \cosh(\alpha x) \sinh(\gamma y) + A_8 \cosh(\alpha x) \cosh(\gamma y).
 \end{aligned} \tag{8.35}$$

In the particular case where a harmonic wave is traveling along the  $\bar{O}y$  axis, the solution can be reduced to

$$w(y, t) = w_0 \exp\left[-i \frac{\omega}{c_f} y\right] \exp[i\omega t]. \tag{8.36}$$

The substitution of equation (8.36) into equation (8.30) leads to the same expression of the bending wave phase velocity given by equation (8.23).

### 8.2.2.3. Acoustic radiation from an infinite plate in an infinite medium

An “infinite” plate is a plate where the dimensions of which are far greater than the wavelength considered and where stationary waves do not occur (the edges are completely absorbent). The displacement field of the plate is described by equation (8.36). The law of continuity of the flexural and acoustic velocities at the surface of the plate, and in the direction perpendicular to the plate, must be verified for any given point  $y$  of the plate. In other words, the particle velocity at the immediate vicinity of the point  $y$  of the plate is equal to the acoustic particle velocity of this point. Consequently, the radiated acoustic field is in the form

$$e^{i(k_z z + k_y y)} e^{i\omega t}, \tag{8.37a}$$

$$\text{where } k_y^2 = \omega \sqrt{M_s / B}, \tag{8.37b}$$

$$\text{with } \frac{\omega^2}{c^2} = k_z^2 + k_y^2. \tag{8.37c}$$

By considering the relationship (8.37b), the equation of dispersion (8.37c) becomes

$$k_z = \left[ \omega \left( \frac{\omega}{c^2} - \sqrt{\frac{M_s}{B}} \right) \right]^{1/2}. \tag{8.38}$$

Two modes of propagation can then be introduced by equation (8.38). The first one, at frequencies above a cut-off frequency ( $\omega > c^2 \sqrt{M_s/B}$ ), is qualified as “propagative” ( $k_z$  is real). The second one, at frequencies below that level, is qualified as “evanescent” ( $k_z$  is a pure complex) or “non-propagative”.

This first example shows that a vibratory state is not necessarily the source of an acoustic field in the surrounding fluid.

Note: the extension of this approach to more complex waveforms can be made using the spatial Fourier transforms as given by equations (4.17), or more particularly (4.18).

#### 8.2.2.4. *The simply supported rectangular plate*

The vibration field of a rectangular and simply supported plate of dimensions ( $a \times b$ ), when harmonically excited can be expanded on the basis of eigenfunctions associated with the following eigenvalue problem

$$\left( \frac{\partial^4}{\partial x^4} + 2 \frac{\partial^4}{\partial x^2 \partial y^2} + \frac{\partial^4}{\partial y^4} - k_{mn}^2 \right) \psi_{mn} = 0, \text{ over } (S), \quad (8.39a)$$

$$\psi_{mn} = 0, \text{ on the perimeter } \mathcal{C}, \quad (8.39b)$$

$$M_x = -B \left( \frac{\partial^2 \psi_{mn}}{\partial x^2} + \nu \frac{\partial^2 \psi_{mn}}{\partial y^2} \right) = 0, \text{ on the perimeter } \mathcal{C}, \quad (8.39c)$$

$$M_y = -B \left( \frac{\partial^2 \psi_{mn}}{\partial y^2} + \nu \frac{\partial^2 \psi_{mn}}{\partial x^2} \right) = 0, \text{ on the perimeter } \mathcal{C}, \quad (8.39d)$$

where by definition  $k_{mn}^2 = \omega_{mn}^2 M_s / B$ . The boundary conditions (8.39b to 8.39d) impose null displacement and bending moment at the perimeter.

If the origin of the coordinates is taken at a corner, the solutions are

$$\psi_{mn} = \frac{2}{\sqrt{ab}} \sin\left(\frac{m\pi x}{a}\right) \sin\left(\frac{n\pi y}{b}\right), \quad (8.40a)$$

$$k_{mn} = \left(\frac{m\pi}{a}\right)^2 + \left(\frac{n\pi}{b}\right)^2. \quad (8.40b)$$



By denoting  $c_{f,mn} = (B/M_s)^{1/4} \sqrt{\omega_{mn}}$ , the bending wave phase velocity when  $\omega^2 = \omega_{mn}^2 = (B/M_s)k_{mn}^2$ , equation (8.40b) becomes

$$k_{mn}^2 = \frac{c_{f,mn}^2}{(B/M_s)} \left[ \left( \frac{m\pi}{a} \right)^2 + \left( \frac{n\pi}{b} \right)^2 \right]. \quad (8.40c)$$

### 8.2.3. Governing equations of thin plane walls

#### 8.2.3.1. Infinite walls

In order to generalize the discussion, a general case is briefly presented in this section. The laws corresponding to particular cases can be deduced from the following propagation equation of a thin plate where  $M_s$  is the mass per unit of area,  $T$  the tension,  $B$  the bending stiffness and  $R$  the damping factor

$$\left( B\Delta^2 w - T\Delta + M_s \frac{\partial^2}{\partial t^2} + R \frac{\partial}{\partial t} \right) w = P. \quad (8.41)$$

The order of magnitude of each term in equation (8.41) varies according to the nature of the material and the thickness of the plate. Two cases are considered: whether inertia is predominant or whether tension and stiffness are not negligible.

#### 8.2.3.2. Finite size walls

For the sake of simplicity, the following expansion of the solution for finite walls in the basis of eigenfunctions is presented in such manner that the approach can be used both for plates and membranes. In both cases, the eigenfunctions satisfy an equation of the form

$$\left[ (-\Delta)^\alpha - k_{mn}^2 \right] \psi_{mn} = 0, \quad (8.42)$$

$$\text{where, for a membrane } \alpha = 1 \text{ and } k_{mn} = \omega_{mn} \sqrt{M_s/T}, \quad (8.43)$$

$$\text{and for a plate } \alpha = 2 \text{ and } k_{mn} = \omega_{mn} \sqrt{M_s/B}. \quad (8.44)$$

This leads to the following common relationship:

$$(-\Delta)^\alpha \equiv k_{mn}^2 \text{ with } k_{mn} = \omega_{mn} \sqrt{M_s/D}, \quad (8.45)$$

$$\text{where } D = T \text{ for a membrane,} \quad (8.46)$$

$$\text{and } D = B \text{ for a plate.} \quad (8.47)$$

Assuming that the eigenfunctions satisfy the same boundary conditions as those associated with the considered problem, the harmonic solution  $w = We^{i\omega t}$  can be written as an expansion in the basis of the eigenfunctions  $\psi_{mn}$ ,

$$W = \sum_{mn} W_{mn} \psi_{mn}. \quad (8.48)$$

The expansion coefficients are obtained from the equation of propagation ( $P$  denoting here the complex amplitude of the pressure loading the wall)

$$\left[ (-\Delta)^\alpha + i\omega \frac{R}{D} - \omega^2 \frac{M_s}{D} \right] W = P/D. \quad (8.49)$$

By using the classical approach presented in Chapter 4, one obtains

$$W_{mn} = \frac{1}{D} \frac{\iint_S P \psi_{mn} dS}{k_{mn}^2 - k_D^2 + i\omega R/D}, \text{ with } k_D = \omega \sqrt{M_s/D}. \quad (8.50)$$

The solution then becomes

$$W(\vec{r}) = \frac{1}{D} \sum_{m,n} \frac{\iint_S P(\vec{r}_0) \psi_{mn}(\vec{r}_0) dS_0}{k_{mn}^2 - k_D^2 + i\omega R/D} \psi_{mn}(\vec{r}). \quad (8.51)$$

Denoting

$$G(\vec{r}, \vec{r}_0) = \sum_{mn} \frac{\psi_{mn}(\vec{r}_0) \psi_{mn}(\vec{r})}{k_{mn}^2 - k_D^2 + i\omega R/D}, \quad (8.52)$$

equation (8.30) can also be written as

$$W(\vec{r}) = \frac{1}{D} \iint_S G(\vec{r}, \vec{r}_0) P(\vec{r}_0) dS_0. \quad (8.53)$$

The function  $G(\vec{r}, \vec{r}_0)$  is the Green's function that satisfies the considered boundary conditions. Equation (8.53) is the integral solution already introduced in the previous chapters and particularly in the study of the motion of membranes (section 6.3.2.1).

### 8.3. Transparency of infinite thin, homogeneous and isotropic walls

In reality, a wall is said to be infinite if its dimensions are large enough so that the amplitude of the bending waves reflected from its edges is negligible compared to the amplitude of the direct waves induced by the forces (pressure) due to the acoustic waves in the surrounding fluid. This assumption is valid as long as internal damping is not negligible.

#### 8.3.1. Transparency to an incident plane wave

##### 8.3.1.1. Reciprocal of the transmission coefficient

An acoustic plane wave (pressure  $p_i$ ) is incident to a wall located at  $z = 0$  in oblique incidence  $\theta$ , generating bending motion in the wall and reflected and transmitted plane waves denoted  $p_r$  and  $p_t$  respectively (Figure 8.7).

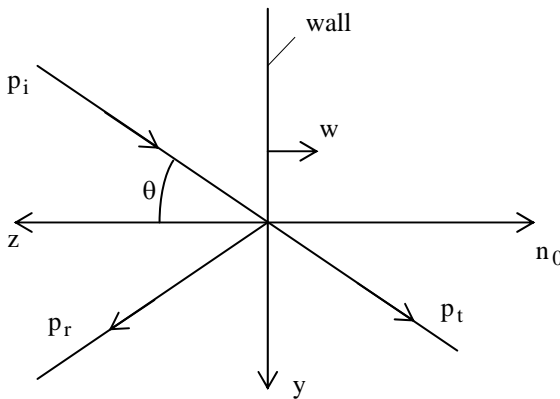

**Figure 8.7.** Incident ( $p_i$ ), reflected ( $p_r$ ), and transmitted ( $p_t$ ) waves by an infinite wall

To find the relationship between the acoustic pressure  $p_t$  and the pressures  $p_i$  and  $p_r$ , one needs to write, in succession, the equation of propagation in the wall, the conditions of continuity at the interfaces, and Euler's equation applied to the acoustic media on both sides of the wall. Thus, an approximate solution to this system of equation, compatible with the nature of the incident wave, can be found.

If the  $\vec{O}y$  axis is chosen to coincide with the projection onto the wall of the direction of incidence (Figure 8.7), the displacement in the  $(-\vec{O}z)$  direction due to the bending motion in the wall satisfies the equation of propagation (8.41)

$$\left( B \frac{\partial^4}{\partial y^4} - T \frac{\partial^2}{\partial y^2} + R \frac{\partial}{\partial t} + M_s \frac{\partial^2}{\partial t^2} \right) w = p_i + p_r - p_t. \quad (8.54)$$

By assuming that the impedance of the material of the wall is significantly greater than the characteristic impedance of the surrounding fluid, there is equality between the normal components  $u$  of the particle velocity in the fluid on both sides of the wall and the velocity  $\partial w / \partial t$  of the wall (the thickness is ignored)

$$u = \partial w / \partial t, \quad (8.55)$$

where the particle velocity “ $u$ ” is related to the gradient of acoustic pressure (Euler’s equation applied on both sides of the wall):

$$\rho \frac{\partial u}{\partial t} = - \frac{\partial p}{\partial (-z)}. \quad (8.56)$$

The energy absorbed and re-emitted by the wall on the receiving side (pressure  $p_t$ ) is assumed small compared to the incident and reflected energy. That way the vibration of the wall can be considered induced only by the incident and reflected waves. Consequently, the vibration displacement of the wall is given by

$$w = W \exp[-ik y \sin \theta] \exp[i\omega t], \quad (8.57)$$

that represents the forced motion of the wall by an incident harmonic plane wave

$$p_i = P_i \exp[ik(z \cos \theta - y \sin \theta)] \exp[i\omega t] \text{ with } k = \omega / c. \quad (8.58)$$

Equation (8.54) shows that the phase velocity  $c / \sin \theta$  of the forced bending waves is supersonic (in the direction of the plate).

Consequently, incident, reflected, and transmitted waves are all harmonic plane waves and their directions make the angle  $\theta$  with the direction perpendicular to the wall. This is a *sine qua non* for equations (8.55) and (8.56) to be satisfied for any given point on the wall.

Thus, equation (8.54) can also be derived by introducing the impedance of the wall as

$$Z = R + i\omega M_s \left[ 1 - \left( \frac{c_T}{c} \sin \theta \right)^2 - \left( \frac{c_f}{c} \sin \theta \right)^4 \right] = (p_i + p_r - p_t) / u, \quad (8.59)$$

where  $c_T$  and  $c_B$  denote respectively the phase velocity in a plate and a membrane.

At  $z = 0$  and on the incident side, Euler's equation is

$$i\omega\rho u = ik(p_i - p_r)\cos\theta, \quad (8.60)$$

and on the receiving side (still at  $z = 0$ ),

$$i\omega\rho u = ik p_t \cos\theta. \quad (8.61)$$

Equation (8.61) shows that the acoustic radiation impedance is equal to  $\rho c/\cos\theta$ , in accordance with equation (6.152) where  $ka \rightarrow \infty$ .

From equations (8.60) and (8.61):

$$u = p_t \cos\theta/(\rho c), \quad (8.62a)$$

$$p_t = p_i - p_r. \quad (8.62b)$$

The substitution of these equations into equation (8.59) gives:

$$\frac{p_i}{p_t} = 1 + \frac{R \cos\theta}{2\rho c} + \frac{i\omega M_s \cos\theta}{2\rho c} \left( 1 - \frac{c_T^2}{c^2} \sin^2\theta - \frac{c_f^4}{c^4} \sin^4\theta \right), \quad (8.63)$$

leading to the reciprocal of the transmission coefficient

$$A(\theta) = \left| \frac{p_i}{p_t} \right|^2 = \left[ 1 + \frac{R \cos\theta}{2\rho c} \right]^2 + \left[ \frac{\omega M_s \cos\theta}{2\rho c} \left( 1 - \frac{c_T^2}{c^2} \sin^2\theta - \frac{c_f^4}{c^4} \sin^4\theta \right) \right]^2. \quad (8.64)$$

Finally, the ratio  $p_0/p_t = (p_i + p_r)/p_t$  is

$$\frac{p_i + p_r}{p_t} = 1 + \frac{R \cos\theta}{\rho c} + \frac{i\omega M_s \cos\theta}{\rho c} \left( 1 - \frac{c_T^2}{c^2} \sin^2\theta - \frac{c_f^4}{c^4} \sin^4\theta \right).$$

## 8.3.1.2. Discussion on the attenuation factor (equation (8.64))

## 8.3.1.2.1. Low frequencies: the mass law

The transmission loss  $TL = 10 \log_{10} A(\theta)$  vanishes at very low frequencies if the damping  $R$  is ignored. However, in practice, such behavior almost never occurs since the wavelengths become significantly greater than the dimensions of the wall.

At low frequencies, since  $c_f^4$  is proportional to  $\omega^2$  (8.23), equation (8.64) is approximated by

$$A(\theta) = \left[ 1 + \frac{R \cos \theta}{2\rho c} \right]^2 + \left[ \frac{\omega M_s \cos \theta}{2\rho c} \left( 1 - \frac{c_T^2}{c^2} \sin^2 \theta \right) \right]^2. \quad (8.65)$$

This is the expression of the attenuation of a membrane. In most situations, the factors associated with the membrane law ( $R \cos \theta / 2\rho c$  and  $c_T^2 \sin^2 \theta / c^2$ ) are negligible, thus

$$A(\theta) \simeq 1 + \left( \frac{\omega M_s \cos \theta}{2\rho c} \right)^2. \quad (8.66)$$

This is the mass law where the inertia of the wall governs the transmission loss. Moreover, the inequality  $\omega M_s / (2\rho c) \gg 1$  is often verified in practice and consequently, at normal incidence,

$$TL_0 = 20 \log_{10} \left( \frac{\omega M_s}{2\rho c} \right) \text{ dB}. \quad (8.67)$$

The attenuation increases by 6dB per octave with the frequency.

## 8.3.1.2.2. Transparency of walls: coincidence and critical frequencies

The motion of walls is generally described as a bending motion of elastic plates. Consequently, neither the reciprocal of the transmission coefficient nor the factor associated with the tension of a membrane is considered. In such conditions, the attenuation factor can be written as

$$A(\theta) = 1 + \left[ \frac{\omega M_s \cos \theta}{2\rho c} \left( 1 - \frac{c_f^4}{c^4} \sin^4 \theta \right) \right]^2, \quad (8.68)$$

with  $c_f^2 = \omega \sqrt{B / M_s}$ .

There exists a particular value of the frequency at which the attenuation factor  $TL = 10 \log_{10} A(\theta)$  vanishes ( $c_f^4 \sin^4 \theta / c^4 = 1$ ). This is the so-called coincidence frequency or frequency of “spatial coincidence”

$$F_f = \frac{c^2}{2\pi \sin^2 \theta} \sqrt{\frac{M_s}{B}} \tag{8.69}$$

The coincidence frequency is greater than the “critical frequency”  $F_c$  defined as the coincidence frequency in grazing incidence  $\theta = \pi/2$  below which the coincidence phenomenon does not occur

$$F_c = \frac{c^2}{2\pi} \sqrt{\frac{M_s}{B}} = \frac{c^2}{2\pi} \left[ \frac{12(1-\nu^2)M_s}{Eh^3} \right]^{1/2} \tag{8.70}$$

Coincidence occurs when, for a given angle of incidence, the frequency of the acoustic wave is equal to the coincidence frequency  $F_f$ , the projection of the plane wave phase velocity in the plane of the wall ( $c / \sin \theta$ ) is equal to the velocity  $c_f$  of the bending waves, or, in other words, when the distance  $\lambda$  between the traces on the wall of two incident wave planes is equal to the wavelength  $\lambda_f$  of the bending waves of the plate (Figure 8.8). The short appellation of coincidence phenomenon implies coincidence of the phase velocity of the acoustic wave along the  $\bar{O}y$  axis and of the bending wave phase velocity of the plate.

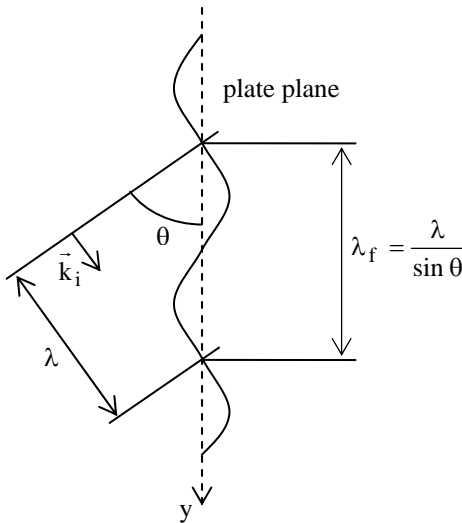

**Figure 8.8.** Interpretation of the phenomenon of coincidence

Figure 8.9 gives the profile of the transmission loss TL in dB around the coincidence frequency.

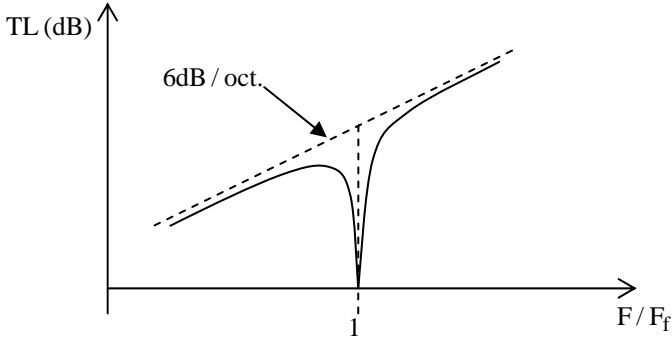

**Figure 8.9.** Transmission loss of a wall around the coincidence frequency

Note: the flexural wave phase velocity  $c_f$  is proportional to the square root of the frequency  $F$ . This result holds only when the product  $(Fh)$  is not large (where  $h$  is the thickness of the plate), which is the case in practice within the typical acoustic frequency range. In practice, the coincidence effect reduces the acoustic isolation of about 10 dB or more at the vicinity of the coincidence frequency.

### 8.3.2. Digressions on the influence and nature of the acoustic field on both sides of the wall

#### 8.3.2.1. Transparency to diffused incident fields

A diffused field can be described as the sum of uncorrelated plane waves of equal intensity  $I$ . The directions of each one of these waves are equally probable. An analogy can be drawn between the degree of diffusivity of a pressure field and its isotropy. The total acoustic intensity is the sum of all individual intensities (corresponding to individual incident waves). The incident energy flow of a diffused field on an element of surface  $dS$  can be written as (by referring to equation (4.47))

$$\phi(E_i) = I dS \int_0^{2\pi} d\varphi \int_0^{\pi/2} \cos \theta \sin \theta d\theta. \quad (8.71)$$



The transmitted energy flow (by definition of the reciprocal of the transmission coefficient  $A(\theta)$ ), is

$$\phi(E_t) = IdS \int_0^{2\pi} d\varphi \int_0^{2\pi} \frac{\cos \theta \sin \theta d\theta}{A(\theta)}. \quad (8.72)$$

The coefficient  $A_d$  in diffused field is readily available

$$\frac{1}{A_d} = \frac{\phi(E_t)}{\phi(E_i)} = \frac{\int_0^{2\pi} \frac{\sin \theta \cos \theta d\theta}{A(\theta)}}{\int_0^{\pi/2} \sin \theta \cos \theta d\theta} = 2 \int_0^{\pi/2} \frac{\sin \theta \cos \theta}{A(\theta)} d\theta. \quad (8.73)$$

When the mass law is satisfied, the integral in equation (8.73) can be estimated by changing the variable of integration into

$$Y = 1 + \left( \frac{\omega M_s \cos \theta}{2\rho c} \right)^2,$$

Then

$$\frac{1}{A_d} = \left( \frac{2\rho c}{\omega M_s} \right)^2 2.3 \log_{10} \left[ 1 + \left( \frac{\omega M_s}{2\rho c} \right)^2 \right]. \quad (8.74)$$

The transmission loss in diffused field is finally

$$\begin{aligned} TL_d &= 10 \log_{10}(A_d) \\ &= 10 \log_{10} \left( \frac{\omega M_s}{2\rho c} \right)^2 - 10 \log_{10} \left[ 2.3 \log_{10} \left[ 1 + \left( \frac{\omega M_s}{2\rho c} \right)^2 \right] \right] \text{ dB}, \end{aligned} \quad (8.75)$$

or, in the particular case where  $\omega M_s / (2\rho c) \gg 1$ :

$$TL_d = TL_0 - 10 \log_{10}(0.23 TL_0) = TL_0 - 10 \log_{10}(TL_0) + 6.4 \text{ dB}, \quad (8.76)$$

where  $TL_0$  is the transmission loss associated with the mass law.

The mass law in diffused field simply indicates an attenuation which is 10 dB less than that of the mass law in normal incidence. However, this law does not provide a very good approximation of experimental results. It is possible to obtain better agreement with experimental data if the integral in equation (8.73) is not upper-bounded by  $\pi/2$ , but by a given angle  $\theta_{\max}$  empirically determined (and which standard value is  $0.78^\circ$ ). This correction can be justified by the incompatibility between the existences of plane waves in grazing incidence and the fact that the wall absorbs energy (since it transmits).

### 8.3.2.2. Properties of acoustic field at the vicinity of a wall: incident plane wave

In view of the conclusion in section 8.3.1.1 (the directions of propagation of transmitted and reflected waves make the same angle  $\theta$  with the direction perpendicular to the wall as the incident wave), the transmitted pressure must be written as

$$p_t = P_t \exp[-ik(y \sin \theta - z \cos \theta)] . \quad (8.77)$$

The amplitude  $P_t$  is a function of the displacement of the wall (from Euler's equation),

$$P_t)_{z=0} = \frac{i\rho\omega^2 W}{k \cos \theta} . \quad (8.78)$$

Combined, these results approximate those obtained when expressing the acoustic field by means of the integral equation (6.63) as follows:

$$\text{for } z < 0, \quad p_t(\vec{r}) = - \iint_S G(\vec{r}, \vec{r}_0) \frac{\partial}{\partial n_0} p(\vec{r}_0) dS_0, \quad (8.79a)$$

for  $z > 0$ ,

$$p_0(\vec{r}) = p_i + p_r = \iiint_D G(\vec{r}, \vec{r}_0) f(\vec{r}_0) dV_0 + \iint_S G(\vec{r}, \vec{r}_0) \frac{\partial}{\partial n_0} p(\vec{r}_0) dS_0, \quad (8.79b)$$

where  $G$  denotes the Green's function satisfying Neumann's condition at the surface of the wall (representing the superposition of the monopolar field and the field from the image source), where  $\frac{\partial p}{\partial n_0} = -i\omega\rho \frac{\partial w}{\partial t}$  and, finally, where  $f(\vec{r}_0)$  represents the action of the sources.

In the case of a monopolar source, given the choice of Green's function, the integral over D represents the acoustic fields from the real and image sources. These fields are plane wave fields in oblique incidence when the sources are assumed at infinity (very distant). Moreover, the integral over S represents the field radiated by the vibrating wall on both sides. The resulting pressure acting on the wall is the sum of the incident pressure  $p_i$ , the reflected pressure  $p_r$  as if the wall was perfectly rigid, and the pressures (of equal amplitudes) created on both sides,

$$P_{z=0} = (p_i + p_r - p_t)_{z=0} = (p_i + p_r' - 2p_t)_{z=0}. \tag{8.80}$$

Since

$$(p_i + p_r')_{z=0} = 2P_i e^{-iky \sin \theta} [\cos(kz \cos \theta)]_{z=0} = 2P_i e^{-iky \sin \theta}, \tag{8.81}$$

denoting  $P_i = \rho c U_i$ , one obtains

$$P_{z=0} = 2\rho c \left[ U_i - \frac{i\omega W}{\cos \theta} \right] \exp(-iky \sin \theta), \tag{8.82}$$

$$\text{or } P_{z=0} = 2\rho c \left( u_i - \frac{i\omega w}{\cos \theta} \right), \tag{8.83}$$

where  $u_i$  is the particle velocity in the incident plane wave at  $z = 0$  and where  $u = i\omega w$  is the normal component of the plate velocity.

Note: if  $Z_0$  denotes the impedance at  $z = 0$  (on the incident side)

$$\frac{p_i + p_r}{Z_0} = u = \frac{(p_i - p_r) \cos \theta}{\rho c}, \tag{8.84}$$

where the last part of the equation is nothing other than equation (8.60).

### 8.3.3. Transparency of a multilayered system: the double leaf system

The double-leaf wall is a commonly encountered case of multilayered structures in building acoustics (double glazing, double doors, partitioning walls, etc.). In this section, this problem is addressed for an infinite system where the leaves are separated by a layer of fluid of thickness  $\ell$ , with density  $\rho_c$  and a characteristics impedance  $Z_c$ . Each leaf is characterized by its own impedance (8.59) denoted  $Z_i$  with  $i = 1$  at  $z = \ell$  and  $i = 2$  at  $z = 0$  (Figure 8.10)

$$Z_i = \frac{P_i + P_r - P_t}{u} = R + i\omega M_s \left[ 1 - \left( \frac{c_T}{c} \sin \theta \right)^2 - \left( \frac{c_f}{c} \sin \theta \right)^4 \right]. \quad (8.85)$$

by considering the mass law where  $R$ ,  $c_T/c$  and  $c_f/c$  are negligible (8.48), this impedance can simply be written as

$$Z_i = i\omega M_s. \quad (8.86)$$

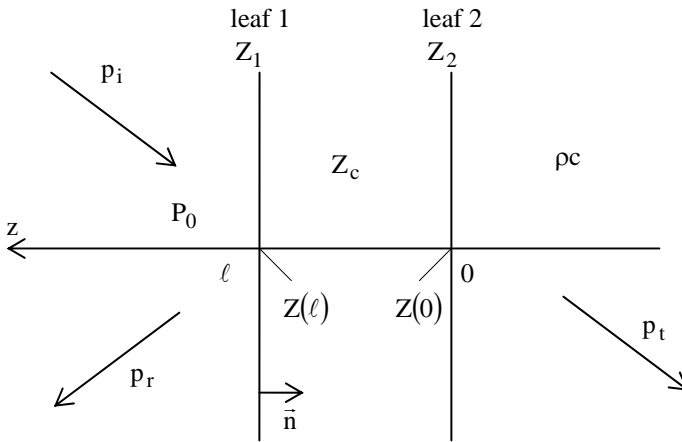

**Figure 8.10.** Multilayered system (double leaf)

Also, assuming for the sake of simplicity that the angle of incidence  $\theta$  is null (normal incidence), equation (8.84) becomes

$$u = (p_i - p_r)/(\rho c) = (p_i + p_r)/Z_0, \quad (8.87)$$

where  $Z_0$  denotes the impedance of the acoustic field at the vicinity of the first leaf on the incident side.

Equations (8.85) and (8.87) are then applied to both sides of the wall using the notations given in Figure 8.10 where the incident medium corresponds to  $z > l$ .

At  $z = l$ ,

$$\left( \frac{P_i + P_r - P_t}{u} \right)_\ell = Z_1, \quad (8.88a)$$

$$u)_{\ell} = \left( \frac{p_i - p_r}{\rho c} \right)_{\ell} = \frac{p_t)_{\ell}}{Z(\ell)}, \quad (8.88b)$$

$$\text{thus } \left( \frac{p_0}{p_t} \right)_{\ell} = \left( \frac{p_i + p_r}{p_t} \right)_{\ell} = 1 + \frac{Z_1}{Z(\ell)}. \quad (8.89)$$

At  $z = 0$ ,

$$\left( \frac{p_i + p_r - p_t}{u} \right)_0 = Z_2, \quad (8.90a)$$

$$u)_{0} = \frac{(p_i + p_r)_0}{Z(0)} = \frac{p_t)_0}{\rho c}, \quad (8.90b)$$

$$\text{thus } \left( \frac{p_0}{p_t} \right)_0 = \left( \frac{p_i + p_r}{p_t} \right)_0 = 1 + \frac{Z_2}{\rho c}. \quad (8.91)$$

The quantity to determine is the ratio  $\frac{(p_i + p_r)_{\ell}}{(p_t)_0}$  and is obtained using equations (8.89) and (8.91) at the condition that a relation between  $(p_t)_{\ell}$  and  $(p_i + p_r)_0$  is found, that is the relation between the pressures in the media at  $z = \ell^-$  and  $z = 0^+$ .

In a stationary regime, the pressure in the region defined by  $z \in ]0, \ell [$  results from the superposition of the waves reflecting back and forth at  $z = 0$  and  $z = \ell$  (equation (4.22))

$$p(z) = A(e^{ikz} + R e^{-ikz}), \quad (8.92)$$

or, denoting  $R = e^{-\alpha} e^{i\pi\sigma}$ :

$$p(z) = B \cos(-kz + \psi), \quad (8.93)$$

where  $B = 2Ae^{i\psi}$  and  $\psi = \frac{\pi\sigma + i\alpha}{2} = \frac{\ln R}{2i}$ . Consequently:

$$\frac{(p_t)_{\ell}}{(p_i + p_r)_0} = \frac{p(\ell)}{p(0)} = \frac{\cos(k\ell - \psi)}{\cos \psi} = \cos(k\ell) + \operatorname{tg}(\psi) \sin(k\ell). \quad (8.94)$$

The remaining unknown  $\psi$  is calculated relating the acoustic impedance  $Z(z)$  with  $z \in (0, \ell)$  to the particle velocity

$$v(z) = \frac{-i}{\rho c \omega} A ik \left( e^{ikz} - R e^{-ikz} \right) = -\frac{i}{Z_c} B \sin(-kz + \psi),$$

and therefore

$$Z(z) = iZ_c \cotg(-kz + \psi) = iZ_c \frac{1 + \operatorname{tg}(kz) \operatorname{tg}(\psi)}{\operatorname{tg}(\psi) - \operatorname{tg}(kz)}. \quad (8.95)$$

Finally:

$$\operatorname{tg}(\psi) = i \frac{Z_c}{Z(0)} = iZ_c \left( \frac{u}{p_i + p_r} \right)_0,$$

or, substituting equations (8.90b) and (8.91),

$$\operatorname{tg}(\psi) = i \frac{Z_c}{\rho c + Z_2}. \quad (8.96)$$

Finally, the solution to the problem is obtained by substituting equations (8.89), (8.91), (8.94) and (8.96) into

$$\frac{p_0}{p_t} = \frac{(p_i + p_r)_\ell}{(p_t)_0} = \frac{(p_i + p_r)_\ell}{(p_t)_\ell} \frac{(p_t)_\ell}{(p_i + p_r)_0} \frac{(p_i + p_r)_0}{(p_t)_0} \quad (8.97)$$

giving

$$\frac{p_0}{p_t} = \left[ 1 + \frac{Z_1 + Z_2}{\rho c} \right] \cos(k\ell) + i \left[ \frac{Z_c}{\rho c} + \frac{Z_1}{Z_c} + \frac{Z_1 Z_2}{\rho c Z_c} \right] \sin(k\ell). \quad (8.98)$$

The ratio  $p_0/p_t$  is not symmetrical with respect to  $Z_1$  and  $Z_2$ .

Also, when  $\ell = n\lambda/2$  ( $n$  is an integer),

$$\frac{p_0}{p_t} = 1 \pm \frac{Z_1 + Z_2}{\rho c}, \quad (8.99)$$

and, in the simplified approximation of the mass law, equation (8.99) becomes

$$\left| \frac{p_0}{p_t} \right|^2 = 1 + \left[ \frac{\omega(M_1 + M_2)}{\rho c} \right]^2. \quad (8.100)$$

Everything then occurs as if the double-leaf wall were replaced by a single leaf structure of equivalent mass  $(M_1 + M_2)$ : the two leaves are then perfectly coupled. The absolute minima of transmission loss (presenting similar profiles as those associated with the coincidence phenomenon (Figure 8.9)) occur at frequencies close to those considered in equation (8.99). These results show that a double wall must be designed with circumspection.

## 8.4. Transparency of finite thin, plane and homogeneous walls: modal theory

### 8.4.1. Generally

In the frequency ranges where the eigenfrequencies of the plate vibrations are detectable (i.e. low frequency range in building acoustics), the discrepancies between the theories presented in section 8.2 and the practice are often unacceptable (with differences that are over 20 dB). This is due to the fact that the dimensions of the wall are not greater than the flexural wavelengths anymore. Consequently, in these frequency ranges, one needs to consider the modes of vibration of the structure (the wave reflected at the boundaries cannot be ignored anymore).

The method of expansion of the solution in the basis of eigenfunctions makes possible a good approximation of the acoustic transparency of finite walls, but presents in practice prohibitive difficulties such as a significantly increased cost of computation when high numbers of modes are to be considered and when the plate (or membranes) are becoming quite different from the ideal cases previously mentioned. In such cases one cannot assume simple analytical eigenfunctions, but requires, for example, the use of Statistical Energy Analysis or numerical methods not presented herein. Nevertheless, when the frequency range considered is favorable to the first few modes of the structures (low frequencies), the modal theory is well suited. At higher frequencies, even though the modal theory is becoming prohibitive in terms of calculation time, its use can still be justified, at least in terms of modal density.

The acoustic field radiated from a finite wall presents complex characteristics, particularly its directivity pattern. This is due to the fact that the elements of surface making up the wall vibrate with different amplitudes and phases governed by the vibration modes of the structure (i.e. Figure 8.11). Consequently, even with a plane

and harmonic incident wave, the transmitted wave cannot be considered plane anymore; its estimation can only be carried out from the solution to the acoustic boundary problem (basic equations and interface conditions), in a semi-infinite space for example.

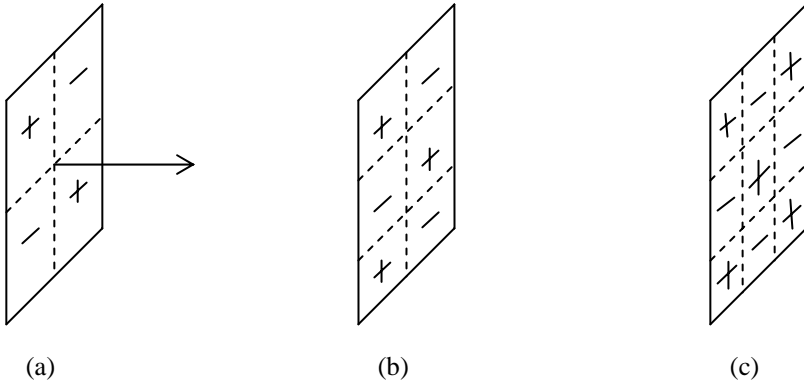
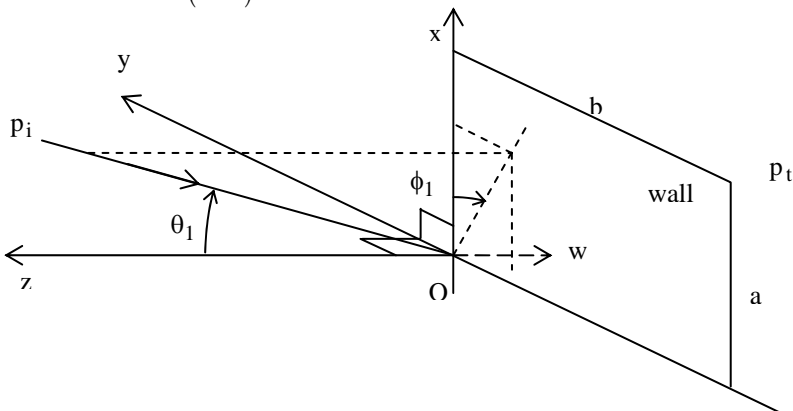

**Figure 8.11.** Examples of modes of vibration of a finite rectangular plate: (a) mode  $n = 2, m = 2$ , (b) mode  $n = 2, m = 3$ , (c) mode  $n = 3, m = 3$

**8.4.2. Modal theory of the transparency of finite plane walls**

8.4.2.1. Governing equations

An incident wave  $p_i(\vec{r})$  that is assumed harmonic (in this section, the time factor  $\exp(i\omega t)$  is suppressed) induces flexural waves in the wall, membrane or plate fixed in an infinite perfectly rigid plane screen at  $z = 0$  (Figure 8.12). The displacement  $w$  is therefore in the  $(-\vec{O}z)$  direction.



**Figure 8.12.** Incident plane wave on a finite plane wall in a perfectly rigid infinite screen



The problem can be posed by writing the equation of motion for the wall and the equations of radiation on each side of the wall and assuming continuity of the normal velocity (or normal displacement) at the interfaces.

8.4.2.1.1. Motion of the wall

The motion of the wall is given by the following equation (8.51):

$$W(\vec{r}) = \frac{1}{D} \sum_{mn} \frac{\iint_S P(\vec{r}_0) \psi_{mn}(\vec{r}_0) d\vec{r}_0}{k_{mn}^2 - k_D^2 + i\omega R / D} \psi_{mn}(\vec{r}), \tag{8.101}$$

where  $P$  denotes the amplitude of the acoustic pressure exerted on the wall,  $W$  the amplitude of the flexural displacement  $w$  of the wall, and where

$$k_D = \omega \sqrt{M_s / D} \text{ (equations (8.46) and (8.47)).}$$

8.4.2.1.2. Equations of acoustic motion

The solutions to the acoustic boundary problem on both sides of the plane  $z = 0$  lead to the expression of the total pressure variation  $P$  on the wall. They can easily be obtained from the integral solution of each of these problems by choosing a Green's function with a null normal derivative in the plane  $z = 0$ . This Green's function (equation (6.7b)) is

$$G(\vec{r}, \vec{r}_0) = \frac{e^{-ik|\vec{r}-\vec{r}_0|}}{4\pi|\vec{r}-\vec{r}_0|} + \frac{e^{-ik|\vec{r}-\vec{r}'_0|}}{4\pi|\vec{r}-\vec{r}'_0|} = g_i + g_r, \tag{8.102}$$

where  $\vec{r}'_0$  is the image of the point at  $\vec{r}_0$  by symmetry with respect to the plane  $z = 0$  and where

$$g_i = \frac{e^{-ik|\vec{r}-\vec{r}_0|}}{4\pi|\vec{r}-\vec{r}_0|} \text{ and } g_r = \frac{e^{-ik|\vec{r}-\vec{r}'_0|}}{4\pi|\vec{r}-\vec{r}'_0|}$$

represent the monopolar field from a source located at  $\vec{r}_0$  and from its image source at  $\vec{r}'_0$ , respectively.

If the point  $\vec{r}_0$  belongs to the plane  $z_0 = 0$ , for any given half-space considered ( $z < 0$  or  $z > 0$ ), the Green's function becomes

$$[G(\vec{r}, \vec{r}_0)]_{z_0=0} = \frac{1}{2\pi} \frac{e^{-ik\sqrt{(x-x_0)^2+(y-y_0)^2+z^2}}}{\sqrt{(x-x_0)^2+(y-y_0)^2+z^2}} = [2g_i]_{z_0=0} = [2g_r]_{z_0=0} \cdot (8.103)$$

The integral solution (equation (6.60)) to the acoustic boundary problem on each side of the wall gives the complex amplitudes of the acoustic pressures on the incident side ( $z > 0$ ) as

$$p_0 = \iiint_D G(\vec{r}, \vec{r}_0) F(\vec{r}_0) d\vec{r}_0 - \iint_S G(\vec{r}, \vec{r}_0) \frac{\partial}{\partial z_0} p(\vec{r}_0) d\vec{r}_0, \quad (8.104)$$

and on the receiving side ( $z < 0$ ) as

$$p_t = \iint_S G(\vec{r}, \vec{r}_0) \frac{\partial}{\partial z_0} p(\vec{r}_0) d\vec{r}_0, \quad (8.105)$$

where D denotes the space occupied by the sources of the incident field and where S denotes the surface of the wall of which transparency is being estimated.

The substitution of Euler's equation

$$\rho\omega^2 W = -\frac{\partial p}{\partial z_0}$$

and the expressions of the incident and reflected field

$$\iiint_D G(\vec{r}, \vec{r}_0) F(\vec{r}_0) d\vec{r}_0 = \iiint_D (g_i + g_r) F d\vec{r}_0 = p_i + p_r', \quad (8.106)$$

where  $p_r'$  denotes the instantaneous amplitude of the reflected pressure estimated in the case where the wall is perfectly rigid (motionless), into equations (8.105) and (8.106) leads respectively to

$$p_t = -\rho\omega^2 \iint_S G(\vec{r}, \vec{r}_0) W(\vec{r}_0) d\vec{r}_0, \quad (8.107a)$$

$$p_0 = p_i + p_r' - p_t. \quad (8.107b)$$

Since  $p_i = p_r$  at  $z=0$ , the complex amplitude of the total pressure loading the wall at  $z=0$  is

$$P_{z=0} = p_i + p_r - 2p_t = 2p_i + 2\rho\omega^2 \iint_S G(\vec{r}, \vec{r}_0) W(\vec{r}_0) d\vec{r}_0. \quad (8.108)$$

Equation (8.108), coupled with the motion  $W$  of the wall (equation (8.101)), constitutes the system of two equations from which the solutions to the problem are obtained.

#### 8.4.2.2. The solutions

The substitution of equation (8.108) into equation (8.101) leads to the integral equation satisfied by the displacement  $W(\vec{r})$  of the wall:

$$W(\vec{r}) = \frac{1}{D} \sum_{mn} \frac{\psi_{mn}(\vec{r})}{k_{mn}^2 - k_D^2 + i\omega R/D} \left[ \iint_S 2p_i(\vec{r}_0) \psi_{mn}(\vec{r}_0) d\vec{r}_0 + 2\rho\omega^2 \iint_S d\vec{r}_0 \iint_S \psi_{mn}(\vec{r}_0) G(\vec{r}_0, \vec{r}') W(\vec{r}') d\vec{r}' \right]. \quad (8.109)$$

By denoting  $A_{mn}$  the expansion coefficients of  $W(\vec{r})$  in the basis  $\{\psi_{mn}\}$  (8.101), the displacement is

$$W(\vec{r}) = \sum_{mn} A_{mn} \psi_{mn}(\vec{r}). \quad (8.110)$$

Substituting this into equation (8.109) gives

$$A_{mn} = \frac{1}{D} \frac{1}{k_{mn}^2 - k_D^2 + i\omega R/D} \left[ \iint_S 2p_i(\vec{r}_0) \psi_{mn}(\vec{r}_0) d\vec{r}_0 + 2\rho\omega^2 \sum_{\mu\nu} A_{\mu\nu} \iint_S d\vec{r}_0 \iint_S \psi_{mn}(\vec{r}_0) G(\vec{r}_0, \vec{r}') \psi_{\mu\nu}(\vec{r}') d\vec{r}' \right]. \quad (8.111)$$

The interpretation of these equations is straightforward. The first term represents the effect of the direct incident and reflected waves on the motion of the wall. The second term, including the influence of the radiated pressure ( $2p_t$ ) on both sides of the wall, represents the inter-modal coupling made possible by the acoustic medium (represented by the Green's function  $G$ ).

In the often-accepted hypothesis that the transmitted pressure  $p_t$  is small compared to the incident pressure, this coupling term can be simplified or even

ignored. To simplify the inter-modal coupling term, one needs to substitute equation (8.108) in the form  $P_{z=0} = 2(p_i - p_t)_{z=0}$  into equation (8.101) giving

$$W(\vec{r}) = \frac{1}{D} \sum_{mn} \frac{\Psi_{mn}(\vec{r})}{k_{mn}^2 - k_D^2 + i\omega R/D} \left[ \iint_S 2p_i(\vec{r}_0) \Psi_{mn}(\vec{r}_0) d\vec{r}_0 - 2 \iint_S p_t(\vec{r}_0) \Psi_{mn}(\vec{r}_0) d\vec{r}_0 \right]. \quad (8.112)$$

To estimate the last term (when assumed small compared to the others), it is possible to use the approximation

$$p_t(\vec{r}_0) \approx i\omega Z W(\vec{r}_0), \quad (8.113)$$

where  $Z$  denotes the mean radiation impedance, independent of the point (given by equation 6.152). Thus, combined with equation (8.110), equation (8.112) becomes

$$A_{mn} \approx \frac{1}{D} \frac{1}{k_{mn}^2 - k_D^2 + i\omega R/D} \left[ \iint_S 2p_i(\vec{r}_0) \Psi_{mn}(\vec{r}_0) d\vec{r}_0 - 2i\omega Z A_{mn} \right] \quad (8.114)$$

and consequently

$$A_{mn} \approx \frac{2 \iint_S p_i(\vec{r}_0) \Psi_{mn}(\vec{r}_0) d\vec{r}_0}{i\omega(2Z + R) - D(k_D^2 - k_{mn}^2)}. \quad (8.115)$$

The substitution of the resulting expansion of  $W$  into equation (8.107a) leads to the expression of the transmitted pressure

$$\frac{p_t(\vec{r})}{|p_i|} = -\rho\omega^2 \sum_{mn} \frac{\frac{2}{|p_i|} \iint_S p_i(\vec{r}_0) \Psi_{mn}(\vec{r}_0) d\vec{r}_0 \iint_S G(\vec{r}, \vec{r}') \Psi_{mn}(\vec{r}') d\vec{r}'}{i\omega(2Z + R) - D(k_D^2 - k_{mn}^2)}. \quad (8.116)$$

When the frequency of the acoustic wave is very close to the eigenfrequency of the wall ( $k_D \simeq k_{mn}$ ), the corresponding  $(m,n)^{\text{th}}$  term of the sum is dominant and the transmission loss is relatively low. This situation is known as ‘‘coincidence of frequency’’.

The transmitted power defined by

$$P = \frac{1}{2} \text{Re} \iint_S p_t(i\omega W)^* d\vec{r} = \frac{\omega}{2} \text{Im} \iint_S p_t W^* d\vec{r} \quad (8.117)$$

can then be written, according to (8.107a) as

$$p = -\frac{\rho\omega^3}{2} \text{Im} \iint_S d\vec{r} \iint_S \mathbf{W}^*(\vec{r}) G(\vec{r}, \vec{r}_0) \mathbf{W}(\vec{r}_0) d\vec{r}_0. \quad (8.118)$$

Note: if only the non-diagonal terms ( $m, n \neq \mu, \nu$ ) of the right-hand side term of equation (8.111) are neglected, the impedance  $Z$  of equation (8.113) would be replaced by the generic tensor

$$Z_{mn} = i\rho\omega \iint_S d\vec{r}_0 \iint_S \psi_{mn}(\vec{r}_0) G(\vec{r}_0, \vec{r}') \psi_{mn}(\vec{r}') d\vec{r}', \quad (8.119)$$

and the non-diagonal terms can then be included by iterative calculation.

### 8.4.3. Applications: rectangular plate and circular membrane

#### 8.4.3.1. Plane wave in oblique incidence on a rectangular plate: transmission in the far field

The notations used in this section are those of Figure 8.12. The coordinate system is chosen according to the geometry of the wall so that the expressions of the vibration modes are simple. The complex amplitude  $p_i(\vec{r})$  of the incident wave depends on three coordinates. For a harmonic plane wave, it is

$$p_i = |p_i| e^{i(k_{x1}x + k_{y1}y + k_{z1}z)}, \quad (8.120)$$

$$\begin{aligned} \text{with } k_{x1} &= k \sin \theta_1 \cos \varphi_1, \\ k_{y1} &= k \sin \theta_1 \sin \varphi_1, \\ k_{z1} &= k \cos \theta_1, \\ k &= \omega / c. \end{aligned}$$

The eigenfunctions of the wall (equation (8.40a)) are

$$\psi_{mn} = \frac{2}{\sqrt{ab}} \sin\left(\frac{m\pi x}{a}\right) \sin\left(\frac{n\pi y}{b}\right), \quad (8.121)$$

where  $a$  and  $b$  are the length and width of the wall.

If the measurement point is assumed to be at great distance from the wall (far field), the Green's function (8.113) is in the form

$$\begin{aligned}
 [G(\vec{r}, \vec{r}_0)]_{z_0=0} &= \left[ \frac{e^{-ik|\vec{r}-\vec{r}_0|}}{2\pi|\vec{r}-\vec{r}_0|} \right]_{z_0=0} \approx \left[ \frac{e^{-ik\left(r-\frac{\vec{r}\cdot\vec{r}_0}{r}\right)}}{2\pi r} \right]_{z_0=0}, \\
 &\approx \frac{e^{-ikr}}{2\pi r} e^{i(k_{x2}x_0+k_{y2}y_0)}, \tag{8.122}
 \end{aligned}$$

with  $k_{x2} = k \sin \theta_2 \cos \varphi_2$ ,

$k_{y2} = k \sin \theta_2 \sin \varphi_2$ ,

where  $\theta_2$  and  $\varphi_2$  locate the receiving point considered in the far field.

In these conditions, the transmitted pressure (8.116) is given by

$$\frac{p_t}{|p_i|} = -\rho\omega^2 \frac{e^{-ikr}}{2\pi r} \sum_{mn} \frac{2f_1(\psi_{mn})f_2(\psi_{mn})}{i\omega(2Z+R) - \frac{D}{2}(k_D^2 - k_{mn}^2)}, \tag{8.123}$$

$$\text{with } f_i(\psi_{mn}) = \sqrt{\frac{2}{a}} \int_0^a \sin\left(\frac{m\pi x}{a}\right) e^{ik_{xi}x} dx \sqrt{\frac{2}{b}} \int_0^b \sin\left(\frac{n\pi y}{b}\right) e^{ik_{yi}y} dy, \quad i=1,2. \tag{8.124}$$

The numerator of the expression of  $p_t/|p_i|$  introduces a product of four Fourier integrals of sine functions. A simple calculation shows that the module of these integrals is equal, for non-null indexes (i.e.  $m \neq 0$  for the first integral) to

$$\frac{2\sqrt{2a}}{m\pi} \frac{\left[ \frac{\sin}{\cos} \right] \left( \frac{k_{x1}a}{2} \right)}{1 - \left( \frac{k_{x1}a}{m\pi} \right)^2}, \text{ for } \frac{k_{x1}a}{m\pi} \neq 1, \tag{8.125a}$$

$$\sqrt{\frac{a}{2}}, \text{ for } \frac{k_{x1}a}{m\pi} = 1, \tag{8.125b}$$

where the trigonometric function to use is “sin” if the associated index is even and “cos” if it is odd.

This result shows the spatial behavior of the considered wave (incident or transmitted). The maximum is obtained when “spatial” coincidence occurs between

the acoustic wave and a vibration mode of the wall. In other words, there is maximum transmission for the  $(n, m)^{\text{th}}$  mode when the projections onto  $\vec{Ox}$  and  $\vec{Oy}$  of two points,  $\lambda/2$  away from each other, defining the direction of propagation of the incident wave, are respectively  $\lambda_{xi}/2$  and  $\lambda_{yi}/2$  away from each other. The distances are then equal to those separating two successive nodes of the flexural motion  $a/m$  and  $b/n$ . Thus

$$\frac{\lambda_{xi}}{2} = \frac{\pi}{k_{xi}} = \frac{a}{m} \quad \text{and} \quad \frac{\lambda_{yi}}{2} = \frac{\pi}{k_{yi}} = \frac{b}{n}, \tag{8.126}$$

$$\text{and finally: } k_{xi} = \frac{m\pi}{a} \quad \text{and} \quad k_{yi} = \frac{n\pi}{b}, \tag{8.127}$$

where  $k_{xi}$  and  $k_{yi}$  denote the projections of the wavenumber on, respectively, the x- and y-axes associated with the wall.

If the coincidence is only partial (only in one direction), the phenomenon is significantly attenuated. However, if the spatial coincidence is combined with the coincidence of frequency (obtained by minimizing the absolute value of the denominator of equation (8.123)), the transmission loss of the wall then presents a deeper trough.

In practice, the coincidence phenomenon is not so localized, but spread over a frequency range called “coincidence zones” (two-dimensional spatial coincidence and coincidence of frequency) and “pseudo coincidence zones” (partial coincidences).

An approximation of the transmitted power can be obtained by substituting the simplified expression of the transmitted pressure (8.113)  $p_t)_{z_0=0} = i\omega ZW$  into equation (8.117)

$$P_t = \frac{\omega}{2} \text{Im} \left[ \iint_S i\omega Z |W|^2 d\vec{r} \right]. \tag{8.128}$$

Consequently,

$$P_t = \frac{\omega^2}{2} \text{Re} \left[ Z \iint_S \sum_{mn} A_{mn} A_{\mu\nu}^* \psi_{mn} \psi_{\mu\nu}^* dx dy \right], \tag{8.129}$$

or, by considering the orthogonality of the eigenfunctions and the expression (8.115) of the  $A_{mn}$  coefficients,

$$\begin{aligned} p_t &= \frac{\omega^2}{2} \operatorname{Re}(Z) \sum_{mn} |A_{mn}|^2, \\ p_t &= \frac{\omega^2}{2} \operatorname{Re}(Z) \sum_{mn} \frac{\left| \iint_S 2p_i(\vec{r}_0) \psi_{mn}(\vec{r}_0) d\vec{r}_0 \right|^2}{\left| i\omega(2Z+R) - D(k_D^2 - k_{mn}^2) \right|^2}, \end{aligned} \quad (8.130)$$

or, by substituting equation (8.124),

$$p_t = \frac{\omega^2 \operatorname{Re}(Z) |2p_i|^2}{2} \sum_{mn} \frac{|f_i(\psi_{mn})|^2}{\left| i\omega(2Z+R) - D(k_D^2 - k_{mn}^2) \right|^2}. \quad (8.131)$$

The transmission coefficient  $T$  can then be written as

$$T = \frac{p_t}{p_i} = \frac{2\rho c p_t}{ab |p_i|^2 \cos \theta_i} = \frac{4\omega^2 \operatorname{Re}(Z) \rho c}{ab \cos \theta_i} \sum_{mn} \frac{|f_i(\psi_{mn})|^2}{\left| i\omega(2Z+R) - D(k_D^2 - k_{mn}^2) \right|^2}. \quad (8.132)$$

A relatively simple relationship can be obtained approximating  $Z$  at low frequencies ( $Z \sim \rho c$ ) (equation (6.152)), assuming normal incidence ( $\cos \theta_i = 1$ ) and ignoring the internal attenuation  $R$  of the wall. Thus

$$F_i(\psi_{mn}) = \begin{cases} \frac{8\sqrt{ab}}{mn\pi^2}, & \text{for } n \text{ and } m \text{ odd,} \\ 0, & \text{otherwise,} \end{cases}$$

the transmission coefficient then becomes

$$T = \sum_{\substack{mn \\ \text{odd}}} \frac{\left[ 8/(mn\pi^2) \right]^2}{1 + \left( \frac{M_s \omega}{2\rho c} \right)^2 \left( 1 - \frac{\omega_{mn}^2}{\omega^2} \right)^2}. \quad (8.133)$$



8.4.3.2. *Transparency of a circular membrane to a plane incident wave at very low frequencies*

The expansion coefficients of the solution  $p_r(\vec{r})/|p_i|$  in the basis of eigenfunctions  $\psi_{mn}$  are proportional to the factor (equation (8.117)):

$$\frac{2}{i\omega(2Z+R) - T(k_T^2 - k_{mn}^2)}.$$

At very low frequencies ( $k_T \ll k_{00}$ ), the first term of the expansion ( $m, n = 0, 0$ ) is dominant and all the others can be ignored. Moreover, bearing in mind the discussion in section 8.3.1, according to which the radiated power is relatively small and the internal dissipation in the material is very small, the factor  $i\omega(2Z+R)$  can, in these particular conditions ( $k_T \neq k_\infty$ ), be ignored. Consequently

$$\frac{2}{i\omega(2Z+R) - T(k_T^2 - k_{00}^2)} \approx \frac{2}{Tk_{00}^2}. \tag{8.134}$$

The substitution of equation (8.134), the expression of the incident pressure

$$\frac{p_i}{|p_i|} = e^{+ik_z z_0 \cos \theta_1 - ik_r r_0 \sin \theta_1 \cos \varphi_1} \tag{8.135}$$

and the eigenfunctions of a membrane of radius “a” for  $(m, n) = (0, 0)$

$$\psi_{00}(r) = \frac{1}{\sqrt{\pi} a J_1(k_{00}a)} J_0(k_{00}r), \tag{8.136}$$

with  $J_0(k_{00}a) = 0$ , thus  $k_{00} a = \gamma_{00} = 2.4$  and  $J_1(k_{00}a) = 0.52$ ,

into equation (8.98) leads to an approximated expression of the transmitted pressure

$$\frac{p_t(\vec{r})}{|p_i|} \approx \frac{\rho\omega^2}{\pi a^2 J_1^2(k_{00}a)} \frac{2\pi \int_0^a J_0(k_{00}r) r dr}{(T/2) k_{00}^2} \iint_S G(\vec{r}, \vec{r}') J_0(k_{00}r') d\vec{r}'.$$

In the far field where  $r \rightarrow \infty$

$$G(\vec{r}, \vec{r}') = \frac{1}{2\pi} \frac{e^{-ik\sqrt{r^2+r_0^2-2rr_0\cos(\varphi-\varphi_0)}}}{\sqrt{r^2+r_0^2-2rr_0\cos(\varphi-\varphi_0)}} \approx \frac{e^{-ikr}}{2\pi r},$$

and, since

$$2\pi \int_0^a J_0(k_{00}r) r dr = 2\pi a^2 \frac{J_1(k_{00}a)}{(k_{00}a)}$$

and

$$\iint_S G(\vec{r}, \vec{r}') J_0(k_{00}r') d\vec{r}' \approx \frac{e^{-ikr}}{r} \int_0^a J_0(k_{00}r') r' dr' = a^2 \frac{e^{-ikr}}{r} \frac{J_1(k_{00}a)}{(k_{00}a)},$$

the transmitted pressure in the far field ( $k_{00}a = \gamma_{00}$ ) is

$$\frac{p_t(\vec{r})}{|p_i|} \approx -\frac{4\rho}{\gamma_{00}^4} \frac{a^4 \omega^2}{T} \frac{e^{-ikr}}{r}. \quad (8.137)$$

It is a wave presenting spherical characteristics and propagating the total acoustic power

$$P_t = \frac{\pi}{\rho c} \left[ \frac{4\rho}{\gamma_{00}^4} \frac{a^4 \omega^2}{T} |p_i| \right]^2. \quad (8.138)$$

The power transmission coefficient is then

$$\mathfrak{F} = \mathfrak{P}_t \left[ \frac{\pi a^2}{\rho c} \frac{|p_i|^2}{2} \right]^{-1} = \frac{32\rho^2}{\gamma_{00}^8} \frac{a^6 \omega^4}{T^2} \approx 4.10^{-2} \frac{a^6 \omega^4}{T^2}. \quad (8.139)$$

This behavioral law at very low frequencies remains valid for any shape of membrane. The factor  $a^6$  simply represents the third power of the surface of the membrane  $\pi^3 a^6$ .

## 8.5. Transparency of infinite thick, homogeneous and isotropic plates

### 8.5.1. Introduction

A plate is considered thick when its thickness is greater than the wavelength of the vibration taking place within it. The mechanisms of transparency can be presented as follows: an acoustic incident plane wave is partly reflected and induces two types of waves in the plate, a longitudinally polarized wave associated with the compression wave and a transverse one (shear wave). Both travel to the other interface (solid-fluid) and induce an acoustic wave in the receiving side (transmitted) and a reflected wave toward the incident side. Stationary waves are created within the plate and medium of incidence. All these phenomena make the modeling rather complex and its interpretation delicate; only the basics of the method are presented here.

The mechanical properties of the plate are entirely described by its thickness  $h_1$ , density  $\rho_1$ , Young's modulus  $E_1$ , and Poisson's ratio  $\nu_1$  of the material. The surrounding fluid is characterized by its density  $\rho$  and the wave speed  $c_0$ . The dissipation factors are ignored.

The fluid loading on the plate is assumed small so that the impedance mismatch is very steep. Thus, the forced vibrational state within the plate is very similar to the state obtained by ignoring the right-hand side term in the governing equation, as in free vibration analysis.

Finally, the normal component of the velocity at the surface is assumed to result from the deformation of the plate normal to the interfaces, otherwise the surrounding fluid (the viscosity of which is ignored) would not be set in motion.

The problem is treated in two steps: by bearing in mind the laws of reflection of a plane wave at a fluid-solid interface and then deducing the resulting transparency.

### 8.5.2. Reflection and transmission of waves at the interface fluid-solid

#### 8.5.2.1. Fundamental equations and boundary conditions

The particle velocity in a homogeneous and isotropic solid medium can be expressed by using a scalar and a vector potentials (equations (1.65) and (2.64)):

$$\vec{v}_1 = \text{grad } \phi_1 + \text{rot } \vec{\psi}_1 \text{ and } \text{div } \vec{\psi}_1 = 0. \quad (8.140)$$

In the particular case of a two-dimensional problem (which is a generalization of the approach presented in section 4.4), the quantities involved depend only on the  $x$ - and  $z$ -coordinates and the directions of propagation belong to the  $xOz$  plane (Figure 8.13). Consequently, the velocity potential  $\bar{\psi}_1$  is such that only its  $y$ -component is not equal to zero. Thus, the components of the velocity in the solid medium are

$$v_{1x} = \partial_x \phi_1 + (\partial_y \psi_{1z} - \partial_z \psi_{1y}) = \partial_x \phi_1 - \partial_z \psi_1, \quad (8.141a)$$

$$v_{1y} = \partial_y \phi_1 + (\partial_z \psi_{1x} - \partial_x \psi_{1z}) = 0, \quad (8.141b)$$

$$v_{1z} = \partial_z \phi_1 + (\partial_x \psi_{1y} - \partial_y \psi_{1x}) = \partial_z \phi_1 + \partial_x \psi_1. \quad (8.141c)$$

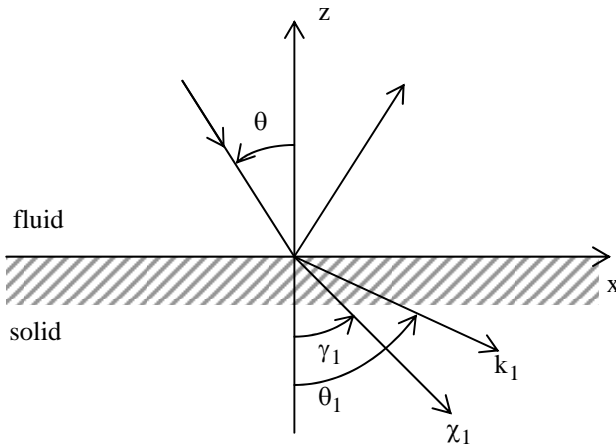

**Figure 8.13.** *Interface fluid-solid*

The strain tensor  $e_{ij}$  in solids (as in equation (2.8) for fluids) is related to the stresses and is expressed as a function of the displacements  $\bar{\xi}_1$

$$e_{ij} = \frac{1}{2} \left( \frac{\partial \bar{\xi}_{1i}}{\partial x_j} + \frac{\partial \bar{\xi}_{1j}}{\partial x_i} \right). \quad (8.142)$$

Hooke's law is written here as

$$\tau_{ij} = \sum_{k\ell} C_{ijk\ell} e_{k\ell}, \quad (8.143)$$

or, for a homogeneous and isotropic solid, as

$$\tau_{ij} = 2\mu_1 e_{ij} + \lambda_1 \delta_{ij} \sum_{\ell} e_{\ell\ell}, \quad (8.144)$$

where  $\mu_1$  and  $\lambda_1$  are called the coefficients of Lamé.

The inverse relationships associated with equation (8.141) are

$$e_{kk} = \frac{1}{E_1} [\tau_{kk} - \nu_1 (\tau_{ii} + \tau_{jj})], \quad (8.145a)$$

$$e_{ij} = \frac{1 + \nu_1}{E_1} \tau_{ij}, \quad (8.145b)$$

where the Young's modulus  $E_1$  and Poisson's ratio  $\nu_1$  are expressed using the coefficients of Lamé

$$E_1 = \frac{\mu_1 (3\lambda_1 + 2\mu_1)}{\lambda_1 + \mu_1} \quad \text{and} \quad \nu_1 = \frac{\mu_1}{2\mu_1 + \lambda_1}, \quad (8.146a)$$

or

$$\lambda_1 = \frac{E_1 \nu_1}{(1 + \nu_1)(1 - 2\nu_1)} \quad \text{and} \quad \mu_1 = \frac{E_1}{2(1 + \nu_1)}. \quad (8.146b)$$

Equations (8.146) are in agreement with equation (8.1). The approach leading to equations (2.67) and (2.68) can only be applied here by first replacing  $\mu$  by  $\mu_1$ ,  $\left(-\frac{2}{3}\mu + \eta\right)$  by  $\lambda_1$  (by comparing equations (2.28) and (8.144)) and the particle velocity  $\bar{v}$  by the displacement  $\bar{\xi}$ . Thus, the potentials  $\phi_1$  and  $\psi_1$ , as the corresponding velocities, satisfy the following equations:

$$\Delta\phi_1 = c_1^{-2} \partial_{tt}^2 \phi_1 \quad \text{with} \quad c_1^2 = (\lambda_1 + 2\mu_1) / \rho_1, \quad (8.147)$$

$$\Delta\psi_1 = b_1^{-2} \partial_{tt}^2 \psi_1 \quad \text{with} \quad b_1^2 = \mu_1 / \rho_1. \quad (8.148)$$

The general form of the equation of propagation for the velocity  $\bar{v}_1$  becomes

$$(\lambda_1 + \mu_1) \text{grad div } \bar{v}_1 + \mu_1 \Delta \bar{v}_1 - \rho_1 \partial_{tt}^2 \bar{v}_1 = 0. \quad (8.149)$$

The normal components of the stresses and displacement must be continuous at the interface fluid-solid and the tangential component of the stresses must be null if the viscosity of the fluid is ignored. In a plane geometry (considered here), the expressions of the tensor of stresses in the solid are

$$\tau_{zz} = 2\mu_1 \partial_z \xi_{1z} + \lambda_1 (\partial_x \xi_{1x} + \partial_z \xi_{1z}), \quad (8.150a)$$

$$\tau_{xz} = \mu_1 (\partial_z \xi_{1x} + \partial_x \xi_{1z}), \quad (8.150b)$$

$$\tau_{yz} = 0, \quad (8.150c)$$

where  $\xi_{1x}$  and  $\xi_{1z}$  are the displacements along, respectively, the x- and z-axes ( $v_{1x} = i\omega \xi_{1x}$ , etc.). In the remainder of this section, the quantities relating to the solid medium will be identified by the subscript "1", while the quantities relating to the fluid will not be indexed.

The elasticity of the fluid medium is characterized by the mass conservation law

$$\rho_0 \chi_s \partial_t p + \rho_0 (\partial_x v_x + \partial_y v_y) = 0,$$

$$\text{thus } -p = \frac{1}{\chi_s} (\partial_x \xi_x + \partial_y \xi_y). \quad (8.151)$$

Consequently, applied to the fluid ( $-p = \tau_{zz}$ ), equations (8.150) become

$$\tau_{zz} = \lambda (\partial_x \xi_x + \partial_z \xi_z) \text{ and } \tau_{xz} = \tau_{yz} = 0, \quad (8.152)$$

where  $\lambda = 1/\chi_s$  and the sound field, when ignoring viscosity, can be described by the velocity potential  $\phi$  satisfying the equation of propagation

$$\Delta \phi = c_0^{-2} \partial_{tt}^2 \phi \text{ with } c_0^2 = \lambda / \rho_0. \quad (8.153)$$

The acoustic pressure and acoustic particle velocity are then

$$p = -i\omega \rho_0 \phi \text{ and } \vec{v} = \text{grad } \phi. \quad (8.154)$$

The associated boundary conditions at  $z=0$  are given by the following equations of

– continuity of  $\tau_{zz}$  :

$$\lambda \Delta \phi = \lambda_1 \Delta \phi_1 + 2\mu_1 (\partial_{zz}^2 \phi_1 + \partial_{xz}^2 \psi_1), \quad (8.155a)$$

– continuity of  $\tau_{xz}$  :

$$0 = 2\partial_{xz}^2 \phi_1 + \partial_{xx}^2 \psi_1 - \partial_{zz}^2 \psi_1, \quad (8.155b)$$

– and continuity of  $v_z$  :

$$\partial_z \phi = \partial_z \phi_1 + \partial_x \psi_1. \quad (8.155c)$$

### 8.5.2.2. Reflection of a plane wave at a fluid-solid interface

The acoustic field in the medium of incidence is the superposition of two harmonic plane waves: the incident wave of velocity potential

$$\phi_{\text{inc}} = A \exp[-ik_0(x \sin \theta - z \cos \theta)], \quad (8.156a)$$

and the reflected wave of velocity potential

$$\phi_{\text{refl}} = A V \exp[-ik_0(x \sin \theta + z \cos \theta)]. \quad (8.156b)$$

The acoustic field on the incidence side is

$$\phi = A [\exp(ik_0 z \cos \theta) + V \exp(-ik_0 z \cos \theta)] \exp(ik_0 x \sin \theta). \quad (8.157)$$

A longitudinal wave and a transverse wave are induced within the solid. Their respective potentials are

$$\phi_1 = A W \exp[-ik_1(x \sin \theta_1 - z \cos \theta_1)], \quad (8.158)$$

$$\psi_1 = A P \exp[-i\chi_1(x \sin \gamma_1 - z \cos \gamma_1)], \quad (8.159)$$

the wavenumbers being defined by  $k_0 = \omega/c_0$ ,  $k_1 = \omega/c_1$  and  $\chi_1 = \omega/b_1$ .

The substitution of equations (8.157) to (8.159) into equations (8.155) at  $z = 0$  gives the angles  $\theta_1$  and  $\gamma_1$  and the coefficients  $V$ ,  $W$  and  $P$ . For example, equation (8.155c) leads to

$$\begin{aligned} (V-1)k_0 \cos \theta = & -W k_1 \cos(\theta_1) \exp[-i(k_1 \sin \theta_1 - k_0 \sin \theta)x] \\ & + P \chi_1 \sin(\gamma_1) \exp[-i(\chi_1 \sin \gamma_1 - k_0 \sin \theta)x]. \end{aligned} \quad (8.160)$$

Since the left-hand side term of equation (8.160) does not depend on  $x$ , the right-hand side term must necessarily be so, implying that

$$k_0 \sin \theta = k_1 \sin \theta_1 = \chi_1 \sin \gamma_1. \quad (8.161)$$

This equation defines the orientations of the propagation vectors. Equation (8.160) can then be written as

$$(V-1)k_0 \cos \theta = -W k_1 \cos \theta_1 + P \chi_1 \sin \gamma_1. \quad (8.162)$$

Similarly, equation (8.155b) leads to

$$W k_1^2 \sin(2\theta_1) + P \chi_1^2 \cos(2\gamma_1) = 0. \quad (8.163)$$

Finally, by adding and subtracting  $(2\mu_1 \partial_{xx}^2 \phi_1)$  from the right-hand side term of equation (8.155a) and considering that

$$\Delta \phi_1 = \partial_{xx}^2 \phi_1 + \partial_{zz}^2 \phi_1,$$

gives, at  $z = 0$ ,

$$\lambda \Delta \phi = (\lambda_1 + 2\mu_1) \Delta \phi_1 + 2\mu_1 \left( \partial_{xz}^2 \psi_1 - \partial_{xx}^2 \phi_1 \right). \quad (8.164)$$

The substitution of the following relationships

$$\lambda = \rho c^2 = \rho \frac{\omega^2}{k^2},$$

$$\lambda_1 + 2\mu_1 = \rho_1 \frac{\omega^2}{k_1^2},$$

$$\mu_1 = \rho_1 \frac{\omega^2}{\chi_1^2},$$

$$\Delta \phi = -k^2 \phi,$$

$$\Delta \phi_1 = -k_1^2 \phi_1,$$

into equation (8.164) gives

$$\frac{\rho_0}{\rho_1} \phi = \phi_1 - \frac{2}{\chi_1^2} \left( \partial_{xz}^2 \psi_1 - \partial_{xx}^2 \phi_1 \right) \text{ for } z = 0. \quad (8.165)$$



Similarly, the substitution of the expressions of  $\phi$  (8.157),  $\phi_1$  (8.158) and  $\psi_1$  (8.159) gives the third equation required to calculate the coefficients V, W and P

$$\frac{\rho_0}{\rho_1}(1+V) = \left(1 - \frac{k_1^2}{\chi_1^2} \sin^2 \theta_1\right) W - P \sin(2\gamma_1). \quad (8.166)$$

Denoting

$$Z = \frac{\rho_0 c_0}{\cos \theta}, \quad Z_1 = \frac{\rho_1 c_1}{\cos \theta_1}, \quad Z_t = \frac{\rho_1 b_1}{\cos \gamma_1}, \quad (8.167a)$$

$$\text{and } Z_+ = Z_1 \cos^2(2\gamma_1) + Z_t \sin^2(2\gamma_1) + Z, \quad (8.167b)$$

and solving the system of equations (8.162), (8.163) and (8.166) while considering equation (8.161) leads to

$$V Z_+ = Z_1 \cos^2(2\gamma_1) + Z_t \sin^2(2\gamma_1) - Z, \quad (8.168a)$$

$$W Z_+ = \frac{\rho_0}{\rho_1} 2Z_1 \cos(2\gamma_1), \quad (8.168b)$$

$$P Z_+ = \frac{\rho_0}{\rho_1} 2Z_t \sin(2\gamma_1). \quad (8.168c)$$

The detailed analysis of these results, particularly the notion of surface waves, is not set out in detail here. The discussion is limited to the two following notes.

Note 1: three situations can be observed:

– i.  $\sin \theta < \frac{c_0}{c_1}$ ,  $\gamma_1$  and  $\theta_1$  real, then equation (8.161) is the classic law of refraction applied to each wave;

– ii.  $\sin \theta > \frac{c_0}{b_1} > \frac{c_0}{c_1}$ ,  $\gamma_1$  and  $\theta_1$  imaginary, the reflection is total for both kinds of waves (exponentially attenuated waves along the  $\vec{Oz}$  axis within the solid);

– iii.  $\frac{c_0}{c_1} < \sin \theta < \frac{c_0}{b_1}$ ,  $\gamma_1$  real and  $\theta_1$  imaginary, only the transverse wave is transmitted.

Note 2: given that the velocities in solids are far greater than the velocities in light fluids, only small incidence angles (a few degrees with respect to the direction perpendicular to the wall) induce transmission.

### 8.5.3. Transparency of an infinite thick plate

The transparency of an infinite thick plate is obtained applying the previous results and considering reflections at the interfaces fluid-solid and solid-fluid inducing a system of stationary waves within the plate (Figure 8.14).

In a stationary regime, the scalar potential  $\phi_1$  and vector potential  $\psi_1 = \psi_{1y}$  (unique component of  $\vec{\psi}_1$ ) are written, according to the definitions of  $\phi'$ ,  $\phi''$ ,  $\psi'$  and  $\psi''$ , as

$$\phi_1 = [\phi' e^{-i\alpha z} + \phi'' e^{i\alpha z}] e^{-i(\sigma x - \omega t)}, \quad (8.169)$$

$$\psi_1 = [\psi' e^{-i\beta z} + \psi'' e^{i\beta z}] e^{-i(\sigma x - \omega t)}, \quad (8.170)$$

where  $\sigma = k_0 \sin \theta = k_1 \sin \theta_1 = \chi_1 \sin \gamma_1$  (8.161),  $\alpha = k_1 \cos \theta_1 = \sqrt{k_1^2 - \sigma^2}$  and  $\beta = \chi_1 \cos \gamma_1 = \sqrt{\chi_1^2 - \sigma^2}$ .

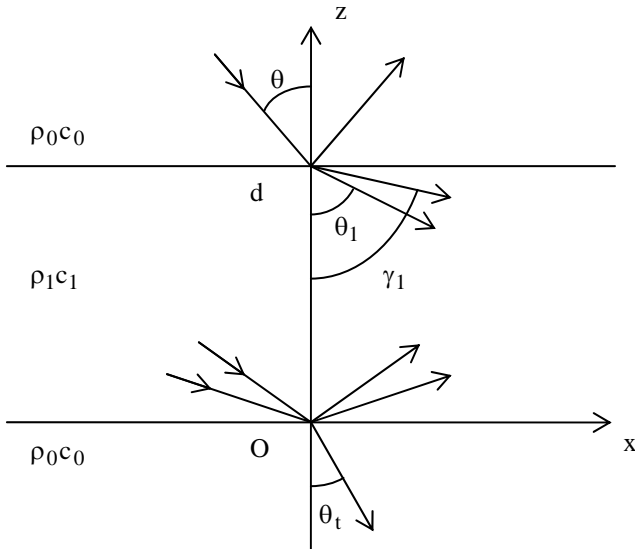

**Figure 8.14.** Reflection and transmission of a thick plate

The common factor  $\sigma$  highlights the equality of the phase velocities at the boundaries for  $\phi_1$  and  $\psi_1$ . It must therefore be related to the phase velocity of the

acoustic components on each side of the plate ( $\theta_t = \theta$ ) when all motions are “forced” by an acoustic incident wave. The previous study on the transparency of thin and finite plates introduced the possibility of coincidence when the phase velocity of the incident wave in the  $\bar{O}x$  direction equates the phase velocity of the free vibrations of the plate.

The substitution of equations (8.169) and (8.170) into equations (8.141) and (8.150) leads to the expression of the normal and tangential components of the velocity and to the stresses in the plate as functions of  $\phi'$  and  $\phi''$  at the point  $z = d$  (side of incidence). By denoting

$$(a_d) = \begin{bmatrix} -i\sigma \cos(\alpha d) & -\sigma \sin(\alpha d) & i\beta \cos(\beta d) & \beta \sin(\beta d) \\ -\alpha \sin(\alpha d) & -i\alpha \cos(\alpha d) & -\sigma \sin \beta d & -i\sigma \cos(\beta d) \\ \frac{i}{\omega}(\lambda k_0^2 + 2\mu\alpha^2) \cos(\alpha d) & \frac{\lambda k_0^2 + 2\mu\alpha^2}{\omega} \sin(\alpha d) & \frac{2\mu}{i\omega} \sigma \beta \cos(\beta d) & \frac{2\mu}{\omega} \sigma \beta \sin(\beta d) \\ \frac{\alpha\sigma}{\omega} \sin(\alpha d) & \frac{i\alpha\sigma}{\omega} \cos(\alpha d) & \frac{\sigma^2 - \beta^2}{2\omega} \sin(\beta d) & \frac{\beta^2 - \sigma^2}{i2\omega} \cos(\beta d) \end{bmatrix} \quad (8.171)$$

one obtains

$$\begin{bmatrix} v_x(d) \\ v_z(d) \\ \tau_{zz}(d) \\ \frac{1}{2\mu_1} \tau_{xz}(d) \end{bmatrix} = (a_d) \begin{bmatrix} \phi' + \phi'' \\ \phi' - \phi'' \\ \psi' - \psi'' \\ \psi' + \psi'' \end{bmatrix}. \quad (8.172)$$

An equivalent relation exists at  $z = 0$ . It can be deduced from equation (8.172) by taking  $d = 0$  in the matrix  $a_d$  (then noted  $a_0$ )

$$\begin{bmatrix} v_x(d) \\ v_z(d) \\ \tau_{zz}(d) \\ \frac{1}{2\mu_1} \tau_{xz}(d) \end{bmatrix} = (A) \begin{bmatrix} v_x(0) \\ v_z(0) \\ \tau_{zz}(0) \\ \frac{1}{2\mu_1} \tau_{xz}(0) \end{bmatrix} \quad (8.173)$$

where  $(A) = (a_d)(a_0)^{-1}$ .

The associated boundary conditions are given below.

- i) Null tangential stresses at  $z = 0$  and  $z = d$

$$\tau_{xz}(0) = \tau_{xz}(d) = 0,$$

or, combined with equation (8.173),

$$\begin{aligned} \frac{1}{2\mu_1} \tau_{xz}(d) &= A_{41}v_x(0) + A_{42}v_z(0) + A_{43}\tau_{zz}(0) + A_{44}\frac{1}{2\mu_1}\tau_{xz}(0), \\ A_{41}v_x(0) + A_{42}v_z(0) + A_{43}\tau_{zz}(0) &= 0. \end{aligned} \quad (8.174)$$

This relationship leads to the expression of  $v_x(0)$  as a function of  $v_z(0)$  and  $\tau_{zz}(0)$ . The substitution of the resulting expression into equation (8.174) gives  $v_z(d)$  and  $\tau_{zz}(d)$  as functions of  $v_z(0)$  and  $\tau_{zz}(0)$ , since  $\tau_{xz}(0) = 0$ ,

$$\begin{bmatrix} v_z(d) \\ \tau_{zz}(d) \end{bmatrix} = (M) \begin{bmatrix} v_z(0) \\ \tau_{zz}(0) \end{bmatrix}, \quad (8.175)$$

$$\text{with } M_{(i-1)(j-1)} = A_{ij} - \frac{A_{i1}A_{4j}}{A_{41}}, \quad i, j = 2, 3. \quad (8.176)$$

ii) The normal components of the stresses and velocities are continuous at each interface (the new notations are obvious)

$$\begin{aligned} \tau_{zz}(d) &= -\rho_0\omega^2(\phi_i + \phi_r), \text{ since } \tau_{zz} = \lambda \Delta\phi = -\lambda k_0^2\phi = -\rho_0c_0^2 k_0^2\phi, \\ \tau_{zz}(0) &= -\rho_0\omega^2\phi_t, \\ v_z(d) &= i\frac{\omega}{c_0}(\phi_i - \phi_r)\cos(\theta), \\ v_z(0) &= i\frac{\omega}{c_0}\phi_t\cos(\theta). \end{aligned} \quad (8.177)$$

The substitution of equation (8.176) into equation (8.177) gives two relationships for the three potentials (one of them is the incident potential, assumed known). The reflection and transmission coefficients (in terms of pressure)  $R = \phi_r / \phi_i$  and  $T = \phi_t / \phi_i$  can then be obtained. For the transmission coefficient, one obtains

$$T = \frac{2Z}{Z(M_{11} + M_{22}) - M_{21} - Z^2M_{12}}, \quad (8.178)$$

$$\text{with } Z = \frac{\rho_0c_0}{\cos\theta}.$$

In the particular case of normal incidence,  $\theta = \theta_1 = \gamma_1 = 0$  and  $k_1 = \chi_1 = \alpha = \beta$ , starting from equation (8.154), the complete calculation becomes fairly simple. By expressing  $(a_d)$ ,  $(a_0)$ ,  $(A) = (a_d)(a_0)^{-1}$ , M and T successively, the transmission coefficient (in terms of energy) becomes

$$|T|^2 = \frac{1}{\cos^2(k_1d) + \sin^2(k_1d) \left[ \frac{\rho_1 c_1}{2\rho_0 c_0} + \frac{\rho_0 c_0}{2\rho_1 c_1} \right]^2}. \tag{8.179}$$

If  $(k_1d) = n\pi$ ,  $|T|^2 = 1$ , then when the thickness of the plate is a multiple of half of the wavelength in the material, the acoustic insulation is null while its maximum occurs when  $k_1d = (2n+1)\pi/2$ .

Finally, if  $\rho_1 c_1 \gg \rho_0 c_0$  and  $k_1d \ll 1$ , equation (8.179) is approximated by

$$|T|^2 = \frac{1}{1 + \frac{\pi^2 d^2}{\lambda_1^2} \left( \frac{\rho_1 c_1}{\rho_0 c_0} \right)^2}. \tag{8.180}$$

This is the mass law at normal incidence for thin walls (equation 8.66) where  $\rho_1 d = M_s$  and  $2\pi c_1 / \lambda_1 = \omega$ .

Note: the problem of reflection by an infinite, thick plate has been the subject of many studies, particularly in the domain of ultrasound. The interpretation of the curves representing the transparency or reflection coefficient is rather difficult and is not presented herein. However, to conclude this section it is important to note that the eigenstates of vibration of the plate, satisfying the homogeneous equation of propagation that is compatible with the boundary conditions, play an important role. There exist two kinds of vibration on each side of the neutral plane of the plate, the symmetrical ones (s curve in Figure 8.15) and the anti-symmetrical one (a curve in Figure 8.15). The notion of coincidence introduced when studying the flexural vibrations of a thin plate can be applied to both kinds of vibrations.

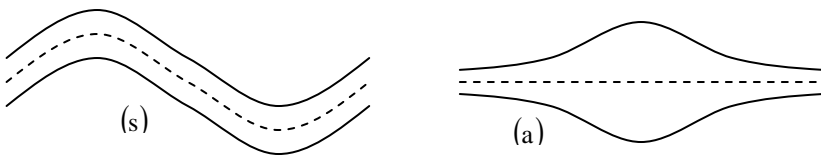

**Figure 8.15.** *Vibration modes of a thick plate: (s) symmetrical, (a) anti-symmetrical*

The numerous experimental validations carried out in the ultrasound domain in water coincide remarkably well with the presented theory. In air and in the audible frequency range, the validation is far more difficult, particularly because of the perturbations due to the finite dimensions of the plate (with respect to the wavelength), the diffraction at the edges, the fact that there are no real plane waves, etc.

## **8.6. Complements in vibro-acoustics: the Statistical Energy Analysis (SEA) method**

### **8.6.1. Introduction**

Problems of vibrations in structures and interactions with surrounding fluids at low frequencies, where the dimensions of the system are smaller than the corresponding wavelengths, are often solved by means of modal theories (as in section 8.4 for the structures and Chapter 9 for closed spaces) or by numerical computations (finite elements or boundary elements). These “deterministic” approaches do not deal very well with the geometric details of the structure, but lead to complete numerical solutions.

Despite the increasing computation power, only the lowest vibration modes can be considered when predicting the vibrational behavior of a structure. The more recent method of SEA allows the description of acoustic and vibration fields in complex structures at high and medium frequency ranges. Its use has therefore been more or less generalized. This method is used for predicting the vibro-acoustic response of complex structures, the localization of sources, energy flow analyses, etc. and particularly responses of systems to white noise.

The SEA method, which has proven very useful in many situations, has restrictive conditions to fulfill and is therefore not always suitable for many vibro-acoustic applications. It assumes that the frequency band of analysis contains a large number of modes (of the considered system) and that these modes are not far apart on the frequency axis (close resonance frequencies). It also assumes that the contribution of modes, the resonance frequencies of which are outside the considered frequency range, is negligible (hypothesis that does not hold for highly-damped systems) and that the spatial distribution of radiations from sources is not affected by their coupling with those modes.

### **8.6.2. The method**

The SEA method is based on the expression of the vibration states in terms of energy stored, dissipated and transmitted. The basic concept is that the vibrational

energy behaves similarly to heat, diffusing from a warm region to a cold region at a rate proportional to the difference of temperature between the two regions. Using this analogy, the mean modal energy per mode ( $E/n$ ) of each sub-system (where  $n$  denotes the number of modes of the sub-system) within a frequency range is equivalent to a measure of the temperature  $T = E/n$  (internal energy of a molecule) of the structure. Thermal conductivity, measuring the intensity of coupling between the sub-systems, is represented by the coupling loss factor  $\zeta_{ij}$ . The heat capacity of the sub-system is then equivalent to the modal density. The variation of energy contained within each sub-system (taken individually) is related to the energy transfers with the adjacent sub-systems and to the energy dissipated within the sub-system. The equations of energy conservation are written for each sub-system and the “global” equations are solved in terms of mean energy of each sub-system.

The energy flow  $P_{ij}$  between two sub-systems  $i$  and  $j$  is assumed proportional to the difference of modal energies

$$P_{ij} = P_{i \rightarrow j} - P_{j \rightarrow i} = \omega \zeta_{ij} \left( \frac{E_i}{n_i} - \frac{E_j}{n_j} \right), \quad (8.181)$$

where  $P_{i \rightarrow j}$  denotes the energy flow from the  $i^{\text{th}}$  sub-system to the  $j^{\text{th}}$  sub-system.

Equation (8.163) is generally written as

$$P_{ij} = \omega \left( \eta_{ij} E_i - \eta_{ji} E_j \right), \quad (8.182)$$

with  $n_i \eta_{ij} = n_j \eta_{ji}$ ,

where  $n_i$  denotes the modal density (number of modes of the  $i^{\text{th}}$  sub-system within the frequency range considered,  $\omega$  centered) and where the coefficients  $\eta_{ij} = \zeta_{ij} / n_i$  denotes the coupling loss factors in the same frequency range (coupling between the two considered sub-systems). Accordingly, the power introduced by the “external sources” into the  $j^{\text{th}}$  sub-system is:

$$Q_j = \omega \eta_{jj} E_j + \sum_{i \neq j}^n \omega \left( \eta_{ji} E_j - \eta_{ij} E_i \right), \quad j = 1, 2, \dots, n, \quad (8.183)$$

where the factor  $(\omega \eta_{jj} E_j)$  denotes the energy dissipated within the sub-system considered.

### 8.6.3. Justifying approach

A global approach is briefly presented here. The time average of the energy received by the  $j^{\text{th}}$  sub-system of a system (see section 1.4) is

$$Q_j = \frac{1}{2} \operatorname{Re} \int_{V_j} (i\omega \xi_j)^* F_j dV_j, \quad (8.184)$$

where  $\xi_j$  denotes the complex amplitude of the displacement and  $F_j$  the complex amplitude of the external forces (external to the  $j^{\text{th}}$  sub-system) applied to the sub-system considered.

The equation of harmonic motion of the  $j^{\text{th}}$  sub-system is then

$$(1 + i\varepsilon_j) L_j \xi_j - (1 - i\gamma_j) \rho_j \omega^2 \xi_j = F_j + F_j^c, \quad (8.185)$$

where  $L_j$  is an auto-adjoint differential operator,  $\rho_j$  the density,  $\varepsilon_j$  and  $\gamma_j$  the dissipation factors, and where  $F_j^c$  represents the forces due to the coupling of the  $j^{\text{th}}$  sub-system with the adjacent sub-systems. The multiplication of the force  $F_j^c$  by  $(i\omega \xi)^*$  and the integration over the volume  $V_j$  of the sub-system leads to

$$\begin{aligned} \int_{V_j} (i\omega \xi_j)^* F_j dV_j &= (1 + i\varepsilon_j) (-i\omega) \int_{V_j} \xi_j^* L_j \xi_j dV_j \\ &+ i\omega^3 (1 - i\gamma_j) \int_{V_j} \rho_j \xi_j^* \xi_j dV_j + i\omega \int_{V_j} \xi_j^* F_j^c dV_j. \end{aligned} \quad (8.186)$$

The properties of the auto-adjoint  $L_j$  are such that one can write

$$\int_{V_j} \xi_j^* L_j \xi_j dV_j = \int_{V_j} \Phi(\xi_j^*, \xi_j) dV_j + \int_{S_j} \bar{A}(\xi_j^*) \cdot \bar{B}(\xi_j) dS_j, \quad (8.187)$$

where the volume integral in the right-hand side term represents the energy density of deformation and the surface integral the associated outgoing energy flow (there is no need to detail the expressions of  $\Phi$ ,  $\bar{A}$  and  $\bar{B}$ ).

By denoting

$$S_j = \frac{1}{2} \int_{V_j} \Phi(\xi_j^*, \xi_j) dV_j \quad (\text{time average distortion energy}),$$



$$T_j = \frac{1}{4} \int_{V_j} \omega^2 \rho_j \xi_j^* \xi_j \, dV_j \quad (\text{time average kinetic energy}),$$

$$R_j = \frac{1}{2} \operatorname{Re} \left[ (\epsilon_j - i) \int_{S_j} \bar{A}(\xi_j^*) \cdot \bar{B}(\xi_j) \, dS_j + i \int_{V_j} \xi_j^* F_j^c \, dV_j \right]$$

(time average energy transferred from the considered sub-system to the adjacent sub-systems,  $\sum_j R_j = 0$ ),

equation (8.184) becomes

$$Q_j = 2\omega\epsilon_j S_j + 2\omega\gamma_j T_j + \omega R_j. \tag{8.188}$$

The two first terms of the right-hand side represent the internal dissipation that, in time average for a random excitation, is of the form  $\omega\eta_{ij}E_j$  of equation (8.183); the remaining term represents the energy flow outgoing from the  $j^{\text{th}}$  sub-system that, in similar circumstances, is written as the second term of equation (8.183).

Note: techniques have been widely developed to access the *in situ* SEA parameters of structures.

## Chapter 9

# Acoustics in Closed Spaces

### 9.1. Introduction

This chapter deals with the problems of acoustics in closed spaces, more precisely in domains ( $D$ ) delimited by closed surfaces ( $S$ ). There are different approaches as to the treatment of such problems depending on the accuracy required, a function of the geometry and dimensions of the considered spaces, and the objective of the problem at hand.

In relation to dimensions and geometry, cavities can be divided into four groups: the “miniature” cavities (where one of the dimensions is of the same order of magnitude as the visco-thermal boundary layers; sections 3.6 to 3.10); the small cavities (where the dimensions are significantly smaller than the considered wavelengths, but remain far larger than the boundary layers; sections 3.5 and 6.3.2.2); the cavities, the dimensions of which are of the same order of magnitude as the considered wavelengths (which require a modal approach, presented here while assuming separable geometry); and finally, the cavities (or rooms) the dimensions of which are larger than the wavelengths considered and where modal theory becomes prohibitive due to the high number of modes to consider.

In practice, and particularly in the case of rooms, the methods most frequently used require a numerical approach relying on Finite Elements or Boundary Elements analysis, methods of the layer potentials, image sources, rays or statistical analysis (Statistical Energy Analysis (SEA)). Only modal and statistical methods are presented in this chapter.

The objective in this chapter is to present the application of modal analysis to acoustic cavities, assuming dissipation during the propagation and at the vicinity of materials with non-null admittances and within the boundary layers. A simple example illustrates the phenomena involved and their interpretations are given. Finally, some asymptotic approximations are presented, leading to the introduction of the classic statistical methods.

## 9.2. Physics of acoustics in closed spaces: modal theory

### 9.2.1. Introduction

#### 9.2.1.1. The analytical signal

In the following section, the solutions in the time domain are obtained by the inverse Fourier transform of the solutions calculated in the Fourier domain and arbitrarily represented by their real parts. The following section is a reminder of these notions and their influence on the definition of wall impedance. A good understanding of the present section, although useful, is not necessary to tackle modal theory.

The harmonic expansion of a real signal, the velocity potential for example

$$\psi(\vec{r}, t) = \frac{1}{2\pi} \int_{-\infty}^{\infty} \psi(\vec{r}, \omega) e^{i\omega t} d\omega, \quad (9.1)$$

introduces negative frequencies. Indeed, any causal real signal  $\Psi(t)$  (the variable  $\vec{r}$  is suppressed when not needed) has a hermitic Fourier transform: the real part is an even function while the imaginary part is odd. Consequently, the function  $\psi(\omega)$  is completely determined when known in the positive frequency range and, accordingly, only this part of the frequency axis will be considered. Thus, if  $\psi(\omega)$  does not present any singularity at the origin (verified by any signal with a non-null mean value), the only distribution to consider is

$$\phi(\omega) = 2U(\omega)\psi(\omega), \quad (9.2)$$

where  $U(\omega)$  denotes the Heaviside's function.

The inverse Fourier transform  $\phi(t)$  of  $2U(\omega)\psi(\omega)$  is then a complex function called the associated analytical signal. Since the inverse Fourier transform of the Heaviside's function  $2U(\omega)$  is

$$\delta(t) + \text{V.P.} \left( \frac{i}{\pi t} \right), \quad (9.3)$$

where V.P. denotes the “principal value”, the inverse Fourier transform of  $2U(\omega)\psi(\omega)$  is given by the convolution product

$$\begin{aligned}\phi(t) &= \left[ \delta(t) + \text{V.P.} \left( \frac{i}{\pi t} \right) \right] * \psi(t), \\ &= \psi(t) + \frac{i}{\pi} \text{V.P.} \int \frac{\psi(\tau)}{t - \tau} d\tau.\end{aligned}\quad (9.4)$$

The function  $\phi(t)$  can then be written as

$$\phi(t) = \psi(t) + i\tilde{\psi}(t), \quad (9.5)$$

where  $\tilde{\psi}(t)$  is called the Hilbert transform of  $\psi(t)$ .

If, for example,  $\psi(t) = \cos \omega_0 t$ , then

$$\begin{aligned}\psi(\omega) &= \frac{1}{2} [\delta(\omega - \omega_0) + \delta(\omega + \omega_0)], \\ \phi(\omega) &= 2U(\omega)\psi(\omega) = \delta(\omega - \omega_0), \\ \tilde{\psi}(t) &= \sin \omega_0 t \quad \text{and} \quad \phi(t) = e^{i\omega_0 t}.\end{aligned}$$

### 9.2.1.2. Consequence on the notion of impedance

In acoustics, if the complex velocity potential is  $\phi(t) = \psi(t) + i\tilde{\psi}(t)$ ,  $\psi(t)$  being the real part of the potential, its Fourier transform is given by

$$\phi(\omega) = 2U(\omega)\psi(\omega). \quad (9.6)$$

For  $\omega > 0$ , the usual specific acoustic admittance  $\beta(\omega)$  is defined (see section 1.3.4, equation (1.70)) by

$$\frac{\partial}{\partial n} \phi(\omega) = -i \frac{\omega}{c_0} \beta(\omega) \phi(\omega). \quad (9.7)$$

An acoustic admittance can then be extrapolated from the real part of the velocity potential as

$$\frac{\partial}{\partial n} \psi(\omega) = -i \frac{\omega}{c_0} \beta(\omega) \psi(\omega). \quad (9.8)$$

For  $\omega > 0$ , this relation is the same as equation (9.7). However,  $\omega < 0$  suggests a particular property of the acoustic impedance  $\beta(\omega)$ . By collecting the real and imaginary parts of equation (9.8) in the form  $\beta = \sigma_1 + i\sigma_2$ , one obtains

$$\begin{aligned} & \operatorname{Re}\left[\frac{\partial}{\partial n}\psi(\omega)\right] + i \operatorname{Im}\left[\frac{\partial}{\partial n}\psi(\omega)\right] \\ &= \frac{\omega}{c_0} \left[ \sigma_2 \operatorname{Re}[\psi] + \sigma_1 \operatorname{Im}[\psi] + i \left( \sigma_2 \operatorname{Im}[\psi] - \sigma_1 \operatorname{Re}[\psi] \right) \right]. \end{aligned} \quad (9.9)$$

The function  $\psi(\omega)$  is hermitian:  $\operatorname{Re}[\psi(\omega)]$  is an even function while  $\operatorname{Im}[\psi(\omega)]$  is odd. Consequently, the real part  $\sigma_1(\omega)$  must be an even function whereas  $\sigma_2(\omega)$  must be odd, thus

$$\beta(-\omega) = \beta^*(\omega). \quad (9.10)$$

This property becomes useful when calculating the inverse Fourier transform by integration about the  $\omega$  axis over the interval  $]-\infty, +\infty[$ .

### 9.2.2. The problem of acoustics in closed spaces

The present study adopts the approximation of linear acoustics in homogeneous and weakly dissipative fluids and in a domain (D) delimited by a closed surface (S). The boundary (S) is assumed to be locally reacting with a specific admittance  $\beta$ . The considered problem, in the time domain, takes a similar form as the problem (6.1)

$$\left\{ \begin{aligned} & \left[ \Delta - \frac{1}{c^2} \frac{\partial^2}{\partial t^2} \right] p(\vec{r}, t) = -f(\vec{r}, t), & \forall \vec{r} \in (D), \quad \forall t \in (t_1, \infty), & (9.11a) \\ & \frac{\partial p(\vec{r}, t)}{\partial n} + \frac{1}{c_0} \frac{\partial \beta(\vec{r}, t)}{\partial t} * p(\vec{r}, t) = U_0(\vec{r}, t), & \forall \vec{r} \in (S), \quad \forall t \in (t_1, \infty), & (9.11b) \\ & \frac{\partial p(\vec{r}, t)}{\partial t} = p(\vec{r}, t) = 0, & \forall \vec{r} \in (D), \quad t = t_1, & (9.11c) \end{aligned} \right.$$

where  $c$  is defined by equation (4.11) or (4.12), the source function  $f$  is given by equation (6.3) and where  $U_0 / (ik_0 \rho_0 c_0)$  denotes the vibration velocity induced at the walls ( $c_0$  being the adiabatic speed of sound).

The initial conditions (at  $t = t_1$ ) are assumed null so that the problem can be solved in the Fourier domain. For example, the integral equation (6.63) is the

Fourier transform of equation (6.60) if the last integral in (6.60) taken at  $t = t_1$  is null. In practice, this hypothesis is not restrictive since an initial acoustic field exists resulting of the sources that eventually vanish at  $t = t_1$ , but its effect can be minimized by shifting the origin of the time domain considered to an anterior time when expressing the source functions  $f$  or  $U_0$ .

The solution to the problem (9.11) is not readily available particularly because of the convolution product in the boundary conditions. The problem is then treated in the Fourier domain. By denoting  $f(\vec{r}, \omega)$ ,  $U_0(\vec{r}, \omega)$ ,  $\beta(\vec{r}, \omega)$  and  $p(\vec{r}, \omega)$ , the respective Fourier transforms of  $f(\vec{r}, t)$ ,  $U_0(\vec{r}, t)$ ,  $\beta(\vec{r}, t)$  and  $p(\vec{r}, t)$ , the problem (9.11) becomes, in the Fourier domain (equation (6.2)),

$$(\Delta + k^2) p(\vec{r}, \omega) = -f(\vec{r}, \omega), \quad \forall \vec{r} \in (D), \quad (9.12a)$$

$$\left[ \frac{\partial}{\partial n} + ik_0 \beta(\vec{r}, \omega) \right] p(\vec{r}, \omega) = U_0, \quad \forall \vec{r} \in (S), \quad (9.12b)$$

where the complex wavenumber  $k = \omega/c$  is given by equation (4.7a) where the molecular relaxation is ignored

$$k = k_0 \left( 1 - \frac{i}{2} k_0 \ell_{vh} \right), \quad k_0 = \omega/c_0. \quad (9.13)$$

The function  $\beta(\vec{r}, \omega)$  is continuous with respect to the variables  $\vec{r}$  and  $\omega$ ; and the problem has then a unique solution. In the following section, the solution is found using the integral formalism (equation (6.63)) requiring an appropriate Green's function satisfying the following boundary conditions in the Fourier domain

$$\left[ (\Delta + k^2) G(\vec{r}, \vec{r}_0) = -\delta(\vec{r}, \vec{r}_0) e^{-i\omega t_0}, \quad \text{in } (D_0), \quad (9.14a) \right.$$

$$\left. \left[ \frac{\partial}{\partial n} + ik_0 \xi(\vec{r}, \omega) \right] G(\vec{r}, \vec{r}_0) = 0, \quad \text{over } (S_0), \quad (9.14b) \right.$$

where the specific admittance  $\xi(\vec{r}, \omega)$  can denote, in simple cases, the "true" admittance  $\beta$  of the cavity walls or the equivalent admittance associated with the boundary layers effects (equation (3.10)) or any other admittance arbitrarily chosen to simplify the mathematics at hand. Sommerfeld's conditions are admissible boundary conditions and can be substituted for equation (9.14b). The domain  $(D_0)$  and the surface  $(S_0)$  considered are assumed very close to (even coinciding with)  $(D)$ , respectively  $(S)$ .

In the context of modal theory, the Green’s function is an expansion in the basis of eigenfunctions associated with the eigenvalue problem

$$\begin{cases} [\Delta + \chi_m^2(\omega)] \psi_m(\vec{r}, \omega) = 0, & \text{in } (D_0), \\ \left[ \frac{\partial}{\partial n} + ik_0 \zeta(\vec{r}, \omega) \right] \psi_m(\vec{r}, \omega) = 0, & \text{over } (S_0), \end{cases} \quad (9.15a)$$

$$\left[ \frac{\partial}{\partial n} + ik_0 \zeta(\vec{r}, \omega) \right] \psi_m(\vec{r}, \omega) = 0, \quad \text{over } (S_0), \quad (9.15b)$$

where “m” is a double or a triple index, and where the eigenvalues  $\chi_m$  and the eigenfunctions  $\psi_m$  depend on the frequency  $\omega$  considered in the problem (9.2), assuming that the boundary condition (9.15b) is not Neumann’s ( $\zeta = 0$ ) and is frequency dependent. The condition of a small value of  $\zeta$  is assumed so that the eigenfunctions are (quasi-)orthogonal (see Appendix to Chapter 4) and even orthonormal.

In the particular case where the admittance  $\xi$  chosen for the Green’s function boundary condition (9.14b) is identical to the admittance  $\zeta$  chosen for the problem (9.15b); the Green’s function in the Fourier domain, its poles and inverse Fourier transform are respectively given by equations (6.20), (6.21) to (6.23) and (6.28).

Another way of defining the above quantities is to expand the Green’s function in the basis of Neumann’s eigenfunctions  $\Phi_m(\vec{r})$ , solutions to the problem (9.15) with  $\zeta = 0$ . These eigenfunctions present the advantage that they are solutions to an auto-adjoint problem (hermitic operator) and are independent of the frequency  $\omega$ . However, they present the inconvenience of corresponding to a null particle velocity at the immediate vicinity of the walls. In most situations, this limitation is not significant since, according to the boundary condition (6.2b), the particle velocity can be written, away from the sources, in the form  $(ik_0 \beta p)$ .

From here the problem is solved by expanding the Green’s function in Neumann’s basis of eigenfunctions  $\Phi_m(\vec{r})$  and by choosing the admittance  $\xi$  (equation (9.14b)) to represent the equivalent specific admittance associated with the boundary layers (equation (3.10)). Thus,  $G(\vec{r}, \vec{r}_0)$  is approximated by (equation (6.44))

$$G(\vec{r}, \vec{r}_0) = \sum_m \left[ k_m^2 - k^2 + ik_0 \iint_{S_0} \xi \Phi_m^2 dS_0 \right]^{-1} \Phi_m(\vec{r}_0) \Phi_m(\vec{r}), \quad (9.16)$$

where  $k_m$  denotes the eigenvalues of Neumann’s problem (eigenvalues  $\chi_m$  for  $\zeta = 0$  in equation (9.15b)). The corresponding Green’s function in the time domain is given by equation (6.28). By writing that

$$ik_0 \iint_{S_0} \xi \Phi_m^2 dS_0 = i\sqrt{i} \left( \frac{\omega}{c_0} \right)^{3/2} \varepsilon_{vhm}, \tag{9.17}$$

$$\text{with } \varepsilon_{vhm} = \iint_{S_0} \left[ \left( 1 - \frac{k_{\perp m}^2}{k_0^2} \right) \sqrt{\ell'_v} + (\gamma - 1) \sqrt{\ell'_h} \right] \Phi_m^2 dS_0, \tag{9.18}$$

the denominator of each expansion coefficient in (9.16) becomes (equation (6.45))

$$k_m^2 - \frac{\omega^2}{c_0^2} \left( 1 - i \frac{\omega}{c_0} \ell_{vh} \right) + i\sqrt{i} \left( \frac{\omega}{c_0} \right)^{3/2} \varepsilon_{vhm} \text{ with } \ell_{vh} = \ell_v + (\gamma - 1)\ell_h. \tag{9.19}$$

The roots of the function (9.19) are given by equation (6.46) as

$$\omega = \pm \omega_m + i\gamma_m, \tag{9.20}$$

$$\text{with } \omega_m \simeq c_0 k_m \text{ and } \gamma_m \simeq \frac{\sqrt{c_0 \omega_m}}{2\sqrt{2}} \varepsilon_{vhm} + \frac{\omega_m^2}{2c_0} \ell_{vh}. \tag{9.21}$$

This Green’s function represents the acoustic field observed at the point ( $\vec{r}$ ) in a domain ( $D_0$ ) with perfectly rigid boundaries, in a dissipative fluid, and generated by the superposition of the fields from a monopolar real source located at ( $\vec{r}_0$ ) and from the set of image sources built using classic geometry.

### 9.2.3. Expression of the acoustic pressure field in closed spaces

#### 9.2.3.1. General solution in the Fourier domain

The solution to the problem (9.12) is found using the integral formalism (equation (6.63)),

$$p(\vec{r}) = \iiint_{(D)} G(\vec{r}, \vec{r}') f(\vec{r}') d\vec{r}' + \iint_{(S)} [G(\vec{r}, \vec{r}') \partial_{n'} p(\vec{r}') - p(\vec{r}') \partial_n G(\vec{r}, \vec{r}')] d\vec{r}' \tag{9.22}$$

where

$$G(\vec{r}, \vec{r}') \partial_{n'} p(\vec{r}') = [-ik_0 \beta(\vec{r}, \omega) p(\vec{r}') + U_0(\vec{r}')] G(\vec{r}, \vec{r}'),$$

$$\text{and } p(\vec{r}') \partial_n G(\vec{r}, \vec{r}') = -ik_0 \xi(\vec{r}', \omega) p(\vec{r}') G(\vec{r}, \vec{r}') + p(\vec{r}') (\partial_{n'} - \partial_{n'_0}) G(\vec{r}, \vec{r}'), \tag{9.23}$$

where  $\partial_{n'} = \vec{n}' \cdot \vec{\nabla}_{r'}$ ,  $\vec{n}'$  denoting a vector normal to the surface ( $S$ ),  
and  $\partial_{n'_0} = \vec{n}'_0 \cdot \vec{\nabla}_{r'}$ ,  $\vec{n}'_0$  denoting a vector normal to the surface ( $S_0$ ).



The substitution of the expression (equation (9.16)) of the Green's function into equation (9.22) and combining the results with equation (9.23) yields

$$p(\vec{r}) = \sum_m A_m \Phi_m(\vec{r}), \tag{9.24a}$$

$$\text{with } A_m = \frac{1}{D_m} \left[ S_m - \sum_v A_v Y_{mv} \right], \tag{9.24b}$$

where

$$D_m = k_m^2 - k^2 + ik_0 \iint_{S_0} \xi \Phi_m^2 dS_0, \tag{9.25a}$$

$$S_m = \iiint_D \Phi_m(\vec{r}') f(\vec{r}') d\vec{r}' + \iint_S \Phi_m(\vec{r}') U_0(\vec{r}') d\vec{r}', \tag{9.25b}$$

$$Y_{mv} = \iint_S \Phi_v(\vec{r}') \left[ ik_0 (\beta - \xi) + (\partial_{n'} - \partial_{n'_0}) \right] \Phi_m(\vec{r}') d\vec{r}'. \tag{9.25c}$$

The acoustic pressure  $p(\vec{r})$  is also obtained as an expansion in the basis of eigenfunctions. The coefficients of expansions are the solutions to the matrix equation

$$([D] + [Y])[A] = [S], \tag{9.26}$$

where  $[D]$  denotes a diagonal matrix, the components of which are  $D_m$ ,  
 $[Y]$  a matrix, the boundary components of which are  $Y_{mv}$ ,  
 $[A]$  a column matrix of unknown components  $A_m$ ,  
 $[S]$  a matrix of source terms  $S_m$ .

The effects of the cavity resonances are introduced by the terms  $D_m$ , denominators of the expansion coefficients  $A_m$ . The factors  $S_m$  represent the energy transfers from the volume sources ( $f$ ) and surface sources ( $U_0$ ) to the modal components of the acoustic field. These transfers are expressed by projecting (inner products in Hilbert's space) the source functions ( $f, U_0$ ) onto the eigenfunction  $\psi_m$  considered (this transfer can be null).

The difference  $(\beta - \xi)$  between the admittance  $\beta$  of the walls and the admittance (of viscous boundary layers, for example) represents the dissipative and reactive effect of the walls from which the dissipative term considered *a priori* in the Green's function (equation (9.16)) is deduced.

The operator  $(\partial_{n'} - \partial_{n'_0})$  represents the effects of irregularities or slope of the real wall (S) with respect to the “fictive” regular wall (S<sub>0</sub>) (the case of irregularity of parallel walls will be addressed in section 9.2.4.1).

The two factors  $(\beta - \xi)$  and  $(\partial_{n'} - \partial_{n'_0})$  appear in a “matrix of transition” between two modes (v and m) representing a modal coupling (transfer of modal energy) due to irregularities in the walls surfaces and/or in the admittance function  $\beta(\vec{r})$  and geometrical irregularities. Depending on the problem at hand, these couplings can be considered favorable or unfavorable. They are desirable in closed spaces if spatial uniformity of the acoustic field is a condition to fulfill. This acoustic diffusion is, in practice, made possible (as in listening rooms) by the absence of parallelism of the cavity walls (parallelism favors the build-up of resonance modes with well-defined pressure maxima and nodes) and by “disorder” in the geometry (such as balconies and corrugated walls for low frequencies, seats and small deflectors for higher frequencies, etc.) and finally by careful distribution of reflecting and absorbing surfaces.

Equation (9.24b) can also be written as

$$A_m = \frac{S_m - \sum_{v \neq m} A_v Y_{mv}}{D_m + Y_{mm}}, \quad (9.27a)$$

where

$$\begin{aligned} D_m + Y_{mm} &= k_m^2 - k^2 \\ &+ \iint_{(S_0)} ik_0 \xi \Phi_m^2 dS_0 \\ &+ \iint_{(S)} \Phi_m [ik_0(\beta - \xi) + (\partial_{n'} - \partial_{n'_0})] \Phi_m dS, \end{aligned}$$

or, at the first order, as

$$D_m + Y_{mm} \simeq k_m^2 - k^2 + \iint_{(S)} \Phi_m [ik_0\beta + (\partial_{n'} - \partial_{n'_0})] \Phi_m dS. \quad (9.27b)$$

The factors of volume dissipation are implicitly considered in the wavenumber  $k$  and those of surface dissipation are represented by the surface integral. The factors of surface dissipation are proportional to the energy  $\Phi_m^2$  of the  $m^{\text{th}}$  mode considered. Note that  $\beta$  can be equal to  $\xi$  in the case of perfectly rigid walls.

## 9.2.3.2. Discussion

Unlike the poles of the Green's function (equation (9.16)) presented in equations (9.18) to (9.21), the poles of the coefficients  $A_m$  (equation (9.27a)) are obtained by solving the following equation:

$$k_m^2 + \left( i \frac{\omega^3}{c_0^3} \ell_{vh} + \iint_{(S)} \Phi_m \left[ \frac{i\omega}{c_0} \beta + (\partial_{n'} - \partial_{n'_0}) \right] \Phi_m dS \right) - \frac{\omega^2}{c_0^2} = 0,$$

or, denoting  $\beta = \sigma_1 + i\sigma_2$ ,

$$\left( k_m^2 - \frac{\omega}{c_0} \iint_{(S)} \sigma_2 \Phi_m^2 dS \right) + \left( \frac{i\omega^3}{c_0^3} \ell_{vh} + \iint_{(S)} \Phi_m \left[ \frac{i\omega}{c_0} \sigma_1 + (\partial_{n'} - \partial_{n'_0}) \right] \Phi_m dS \right) = \frac{\omega^2}{c_0^2}. \quad (9.28a)$$

By ignoring the smaller term  $\sigma_2$ , even for  $m=0$  (which induces a small error in the real part of the pole and thus in the resonance frequencies) and denoting

$$\eta(\omega) = \frac{c_0}{2k_m} \left( \frac{\omega^3}{c_0^3} \ell_{vh} + \iint_{(S)} \Phi_m \left[ \frac{\omega}{c_0} \sigma_1 - i(\partial_{n'} - \partial_{n'_0}) \right] \Phi_m dS \right),$$

equation (9.28a) can be approximated at the first order by

$$\omega^2 = [c_0 k_m + i\eta(\omega)]^2. \quad (9.28b)$$

The approximated solutions of equation (9.28b)

$$\omega \approx \pm [c_0 k_m + i\eta(\pm c_0 k_m)],$$

are solutions in the form

$$\omega \approx \pm \omega_m + i\gamma_m, \quad (9.29)$$

where  $\gamma_m = \eta(c_0 k_m)$  since  $\eta(c_0 k_m) = -\eta(-c_0 k_m)$ ,  $\sigma_1$  being an odd function (equation (9.10)). The factor  $\gamma_m$  is clearly related to the dissipative factors that are null in absence of dissipation.

Consequently, the expression (9.27a) of the expansion coefficients  $A_m$  can be written, according to the expression of the poles (equation (9.29)), as

$$A_m = \frac{S_m - \sum_{v \neq m} A_v Y_{mv}}{- (\omega - i\gamma_m - \omega_m)(\omega - i\gamma_m + \omega_m) / c_0^2}. \tag{9.30}$$

The resonance angular frequencies associated with the eigenvalues of the matrix in equation (9.26) are, *a priori*, very close to  $\omega_m$  since  $\gamma_m \ll \omega_m$ , and are given by  $\omega = \omega_m + \varepsilon$ , where  $\varepsilon$  is a real number significantly inferior to  $\omega_m$ , obtained by minimizing the modulus of the denominator of  $A_m$  in equation (9.30), calculating the value of  $\varepsilon$  that minimizes the term

$$|(\omega_m + \varepsilon - i\gamma_m - \omega_m)(\omega_m + \varepsilon - i\gamma_m + \omega_m)| \approx 2\omega_m |\varepsilon - i\gamma_m| = 2\omega_m \sqrt{\varepsilon^2 + \gamma_m^2}. \tag{9.31}$$

The minimum is obtained for  $\varepsilon = 0$  and, consequently, the resonance frequency is given by

$$\omega = \omega_m. \tag{9.32}$$

Moreover, for  $\varepsilon = \pm\gamma_m$ , the reciprocal of equation (9.31) is equal to half of its maximum value (-3 dB). Thus, the width at half height of the resonance peaks (Figure 9.1) is equal to  $(2\gamma_m)$  and the corresponding quality factor (ratio of the energy of the system in resonance to the energy dissipated per cycle) is

$$Q_m = \frac{\omega_m}{2\gamma_m}. \tag{9.33}$$

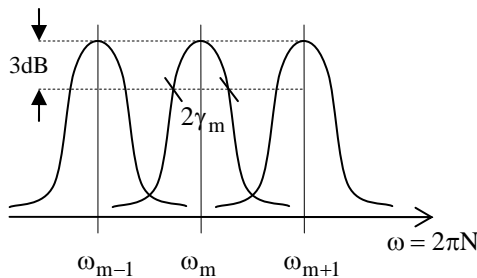

**Figure 9.1.** Resonance frequencies and width of resonance peaks

A relative uniformity of the acoustic field in the domain (D) is obtained when the difference  $(\omega_m - \omega_{m-1})$  between two consecutive resonances is significantly

smaller than the factor  $(2\gamma_m)$ . The resonance peaks are then superposed and for a given frequency of emission from the sources, a significant number of modes are excited (with non-negligible amplitudes). The modal density is then high enough for the energy distribution to be considered independent of the observation point in  $(D)$ .

9.2.3.3. Particular solution in weak inter-modal coupling

In the rather common cases where the factors associated with the reaction of the walls in the surface integral of equation (9.15c) are relatively uniform over the integration surface, the non-diagonal terms  $Y_{mv}$  are small compared to the diagonals terms. This is a consequence of the properties of  $\Phi_m$ . The inter-modal coupling is then so small that one can ignore it as a first approximation and the solution to the problem takes, according to equations (9.24a) and (9.27a), the form

$$p(\vec{r}) = \sum_m \frac{S_m}{D_m + Y_{mm}} \Phi_m(\vec{r}), \tag{9.34a}$$

with

$$S_m = \iiint_D \Phi_m(\vec{r}') f(\vec{r}') d\vec{r}' + \iint_S \Phi_m(\vec{r}') U_0(\vec{r}') d\vec{r}', \tag{9.34b}$$

$$D_m + Y_{mm} \simeq k_m^2 - k^2 + \iint_S \Phi_m [ik_0\beta + (\partial_{n'} - \partial_{n'_0})] \Phi_m dS, \\ \simeq -(\omega - i\gamma_m - \omega_m)(\omega - i\gamma_m + \omega_m) / c_0^2 = k_m^2 - k_0^2 + 2ik_0\gamma_m / c_0, \tag{9.34c}$$

where  $k_m$  and  $\Phi_m$  denote the eigenvalues and eigenfunctions associated with Neumann’s eigenvalue problem (equation (9.15) with  $\zeta = 0$ ).

This form of solution is often well suited to the description of acoustic pressure fields. However, it does not lead to a complete solution of problems where the particle velocity (or energy flow) at the walls is an unknown unless the boundary condition (9.12b) to express the particle velocity is taken into consideration.

**9.2.4. Examples of problems and solutions**

9.2.4.1. Examples of inter-modal coupling

9.2.4.1.1. Non-parallelism of walls of a parallelepipedic cavity

The light non-parallelism of walls of a rectangular cavity can be described by the small angle  $\theta$  made by two facing walls (Figure 9.2).

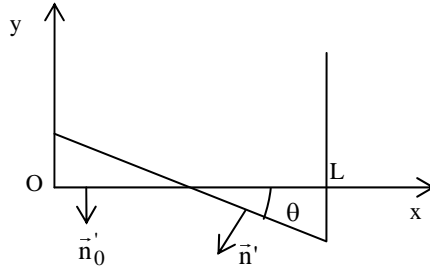

**Figure 9.2.** Non-parallelism of a wall – notations

The coupling term in equation (9.25c) has already been presented and is

$$\iint_S \Phi_v(\vec{r}')(\partial_{n'} - \partial_{n'_0})\Phi_m(\vec{r}')dr' \quad , \quad (9.35a)$$

where

$$\begin{aligned} \partial_{n'} - \partial_{n'_0} &= (\vec{n}' \cdot \vec{\nabla}) - (\vec{n}'_0 \cdot \vec{\nabla}) \\ &\approx \left( -\sin \theta \frac{\partial}{\partial x} - \cos \theta \frac{\partial}{\partial y} \right) + \frac{\partial}{\partial y} \approx -\theta \frac{\partial}{\partial x}. \end{aligned} \quad (9.35b)$$

The inter-modal coupling is therefore proportional to the angle  $\theta$  and the spatial variation of the mode at the origin of the coupling about the direction parallel to the wall.

9.2.4.1.2. Inertial coupling by Coriolis effect

In a cavity submitted to a rotational velocity  $\vec{\Omega}$ , the Coriolis effect forces on the vortical motions in the boundary layers is described by a volume force exerted onto the fluid and given by equation (3.196):

$$\text{div } \vec{f}_c = -2 \frac{k_v}{\omega} e^{ik_v u} \vec{\Omega} \cdot \left[ \vec{u} \wedge \vec{\nabla}_{\vec{w}} p(0, w_1, w_2) \right], \quad (9.36)$$

( $\wedge$  denotes the cross product).

This factor varies in time with the same frequency as the pre-existing acoustic field  $p_a$ . Since no vortical modes are assumed outside the boundary layers (at the walls,  $u \approx 0$ ), the integration of the Coriolis source factor  $S_m = \iiint_{(D)} \Phi_m(\vec{r}') f(\vec{r}') d\vec{r}'$ , here

$$S_m)_c = - \iiint_D \Phi_m(\vec{r}') \operatorname{div} [\vec{f}_c(\vec{r}')] d\vec{r}' \quad , \quad (9.37)$$

can be directly obtained with respect to the normal component  $u$  over the interval  $]-\infty, 0]$  by replacing the pressure  $p$  by its expansion (equation (9.24a)) and noting that  $\lim_{u \rightarrow -\infty} e^{ik_v u} \rightarrow 0$ , thus

$$S_m)_c = \sum_v \frac{2A_v}{i\omega} \iiint_S \Phi_m(\vec{r}') \bar{\Omega} [\vec{u} \wedge \vec{\nabla}_{\vec{w}} \Phi_v(\vec{r}')] d\vec{r}' ,$$

which can also be written as

$$S_m)_c = \sum_v A_v Y_{vm} \quad , \quad (9.38)$$

$$\text{with } Y_{vm} = \frac{2}{i\omega} \iiint_S \Phi_m(\vec{r}') \bar{\Omega} [\vec{u} \wedge \vec{\nabla}_{\vec{w}} \Phi_v(\vec{r}')] d\vec{r}' . \quad (9.39)$$

As seen in Chapter 3 (equation (3.11)), the Coriolis forces do have an effect on the energy transfers between cavity modes at the vicinity of the cavity walls.

#### 9.2.4.2. Examples of solutions in the time domain: reverberation

In this section, the solution of the problem (9.11) in the time domain is presented as the inverse Fourier transform of the uncoupled solution (9.34) obtained in the Fourier domain for two different types of sources functions  $f(\vec{r}')$ .

##### 9.2.4.2.1. Punctual source

A harmonic source function (of angular frequency  $\omega_g$ ) is described in the time domain by

$$f(\vec{r}', t) = \rho_0 \frac{\partial}{\partial t} [Q_0 \delta(\vec{r}' - \vec{r}_0) H(-t) \sin(\omega_g t)] , \quad (9.40)$$

where  $H$  is the Heaviside step function and  $Q_0$  is the strength of the source.

In the Fourier domain, this source function becomes

$$\begin{aligned} f(\vec{r}') &= \rho_0 i \omega Q_0 \delta(\vec{r}' - \vec{r}_0) \left[ \pi \delta(\omega) - \text{V.P.} \frac{1}{i\omega} \right] * i\pi \left[ \delta(\omega + \omega_g) - \delta(\omega - \omega_g) \right], \\ &= \rho_0 i \omega Q_0 \delta(\vec{r}' - \vec{r}_0) \pi \left[ i\pi \delta(\omega + \omega_g) - i\pi \delta(\omega - \omega_g) + 2\text{V.P.} \frac{\omega_g}{\omega^2 - \omega_g^2} \right]. \end{aligned} \quad (9.41)$$

The substitution of this expression into equation (9.34) with  $U_0 = 0$  leads, by the method of residues, to the inverse Fourier transform

$$\text{– for } t < 0, \quad p(\vec{r}, t) = \rho_0 c_0^2 Q_0 \omega_g \sum_m B_m \cos(\omega_g t + \Gamma_m), \quad (9.41a)$$

$$\text{– for } t > 0, \quad p(\vec{r}, t) = \rho_0 c_0^2 Q_0 \omega_g \sum_m C_m e^{-\gamma_m t} \cos(\omega_m t + \Omega_m), \quad (9.41b)$$

with

$$B_m e^{i\Gamma_m} = \frac{\Phi_m(\vec{r}_0) \Phi_m(\vec{r})}{\omega_g^2 - \omega_m^2 - 2i\omega_g \gamma_m}, \quad (9.42a)$$

$$C_m e^{i\Omega_m} = \frac{\Phi_m(\vec{r}_0) \Phi_m(\vec{r})}{\omega_g^2 - (\omega_m + i\gamma_m)^2}. \quad (9.42b)$$

Before extinction of the source ( $t < 0$ ), the acoustic field is periodic of angular frequency  $\omega_g$ . The energetic modes are those where the resonance frequency is close to the frequency of the source: it is simply a forced motion of the particle, the energy of which is determined by superposition of the eigenfunctions  $\Phi_m(\vec{r})$  weighted by their respective amplitudes. The energy transfer from the source to a given mode is proportional to the value of the eigenfunction at the source  $\Phi_m(\vec{r}_0)$ .

After extinction of the source, each mode oscillates at its own resonance angular frequency  $\omega_m$ , its amplitude decaying with time with the associated modal dissipation factor  $\gamma_m$ . The energetic resonances remain those of the most energetic modes at  $t = 0$ , meaning those the resonance frequency of which is close to the frequency of the source. Thus, the system keeps “in memory” the frequency of the source and returns a sound field containing only frequencies close to  $\omega_g$  and the auditory feeling that the sound field at  $\omega_g$  is sustained for a period of time known as the reverberation time.

#### 9.2.4.2.2. Punctual impulse source at $t = 0$

The source function in the time domain is

$$f(\vec{r}', t) = \rho_0 Q_0 \delta(\vec{r}' - \vec{r}_0) \delta(t). \quad (9.43)$$



The same method as in section 9.2.4.2.1 leads to the acoustic pressure

$$\text{for } t < 0, \quad p(\vec{r}, t) = 0, \tag{9.44a}$$

$$\text{for } t > 0, \quad p(\vec{r}, t) = \rho_0 c_0^2 \sum_m A_m e^{-\gamma_m t} \sin(\omega_m t + \varphi_m), \tag{9.44b}$$

with

$$A_m e^{i\varphi_m} = \frac{\Phi_m(\vec{r}_0) \Phi_m(\vec{r})}{\omega_m + i\gamma_m}. \tag{9.45}$$

The reverberant field ( $t > 0$ ) results from the superposition of all modes oscillating at their respective resonance angular frequency  $\omega_m$ . The amplitude of each mode decays in time with its respective dissipation factor  $\gamma_m$  and no mode is significantly more energetic than another since the frequency spectrum of the source is “infinite”. The only modes that might not contribute to the reverberant field are those for which  $\Phi_m(\vec{r}_0) = 0$ .

### 9.2.4.3. Eigenfunctions of a cavity with general boundary conditions

It is possible to adopt the same approach as in sections 9.2.2 and 9.2.3 using eigenfunctions satisfying mixed boundary conditions if the admittance  $\zeta$  (9.15b) is small (see Appendix to Chapter 4). These conditions can be, among others, those associated with the visco-thermal boundary layers. The admittance  $\zeta(\vec{r}, \omega)$  denotes the equivalent admittance given by equation (3.10) and the Green’s function satisfying these boundary conditions (equation (9.16)) is here given by equation (6.20) where the notation  $\chi_m$  replaces  $k_m$ ,

$$G(\vec{r}, \vec{r}_0) = \sum_m \left[ \chi_m^2(\omega) - k^2 \right]^{-1} \psi_m(\vec{r}_0, \omega) \psi_m(\vec{r}, \omega), \tag{9.46}$$

where, by comparison with equations (9.16) and (9.34c),

$$\chi_m^2(\omega) \approx k_m^2 + ik_0 \iint_{S_0} \zeta \psi_m^2 dS_0.$$

By ignoring the real part of the second factor in the right-hand side term (the contribution of which to the resonance frequencies is generally small)

$$\begin{aligned} \chi_m^2(\omega) &\approx k_m^2 + ik_0 \operatorname{Re} \left[ \iint_{S_0} \zeta \psi_m^2 dS_0 \right], \\ &\approx k_m^2 + ik_0 \frac{2\gamma_m^0}{c_0}, \end{aligned} \tag{9.47}$$

where  $\gamma_m^0$  denotes the factor  $\gamma_m$  (equations (9.28) and (9.29)) when dissipation at the boundaries is considered, and where the contribution of  $k_0 \ell_{vh}$  (dissipation of volume) is ignored.

Here the eigenvalues and eigenfunctions depend on the angular frequency  $\omega$  considered (in the Fourier domain) so that, when solving the previous problems in the time domain (section 9.2.4.2), the eigenfunctions  $\Phi_m(\vec{r})$  must be replaced by  $\Psi_m(\vec{r}, \omega_g)$  in equations (9.42) and by  $\psi_m(\vec{r}, \omega_g + i\gamma_m)$  in equation (9.45).

In the case of a parallelepipedic cavity, the eigenfunctions and eigenvalues are directly obtained from the solutions to the problem

$$\left[ \frac{\partial^2}{\partial x^2} + \frac{\partial^2}{\partial y^2} + \frac{\partial^2}{\partial z^2} + \chi_m^2 \right] \psi_m = 0, \quad \forall x \in (0, \ell_x), \quad \forall y \in (0, \ell_y), \quad \forall z \in (0, \ell_z), \quad (9.48a)$$

$$\frac{\partial \psi}{\partial x} = ik_0 \zeta_{x_0} \psi \text{ at } x = 0 \text{ and } \frac{\partial \psi}{\partial x} = -ik_0 \zeta_{x_1} \psi \text{ at } x = \ell_x, \quad (9.48b)$$

$$\frac{\partial \psi}{\partial y} = ik_0 \zeta_{y_0} \psi \text{ at } y = 0 \text{ and } \frac{\partial \psi}{\partial y} = -ik_0 \zeta_{y_1} \psi \text{ at } y = \ell_y, \quad (9.48c)$$

$$\frac{\partial \psi}{\partial z} = ik_0 \zeta_{z_0} \psi \text{ at } z = 0 \text{ and } \frac{\partial \psi}{\partial z} = -ik_0 \zeta_{z_1} \psi \text{ at } z = \ell_z. \quad (9.48d)$$

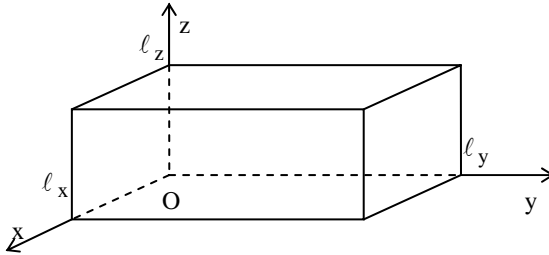

**Figure 9.3.** *Parallel epipedic cavity*

For the sake of generalization, the admittances at  $x = 0$ ,  $y = 0$  and  $z = 0$  are differentiated from the admittances at  $x = \ell_x$ ,  $y = \ell_y$  and  $z = \ell_z$  respectively. In the following section, when associated with the visco-thermal boundary layers, these values are assumed uniform and equal for opposite walls.

It is straightforward to verify that the solutions can be written as

$$\psi_m(\vec{r}, \omega) = C_{m_x}(x)C_{m_y}(y)C_{m_z}(z), \tag{9.49}$$

$$\chi_m^2 = \chi_{m_x}^2 + \chi_{m_y}^2 + \chi_{m_z}^2, \tag{9.50}$$

with

$$C_{m_x}(x) = \sqrt{\frac{2 - \delta_{m_x} 0}{\ell_x}} \cos\left(\chi_{m_x} x - i\zeta_{x_0} \frac{k_0}{\chi_{m_x}}\right), \tag{9.51}$$

$$\chi_{m_x}^2 = \left(\frac{m_x \pi}{\ell_x}\right)^2 + i(2 - \delta_{m_x} 0) \frac{k_0}{\ell_x} (\zeta_{x_0} + \zeta_{x_1}). \tag{9.52}$$

Similar formulae can be obtained for  $C_{m_y}(y)$ ,  $C_{m_z}(z)$ ,  $\chi_{m_y}^2$  and  $\chi_{m_z}^2$ . Equation (9.50) becomes

$$\begin{aligned} \chi_m^2 = k_m^2 + i(2 - \delta_{m_x} 0) \frac{k_0}{\ell_x} (\zeta_{x_0} + \zeta_{x_1}) \\ + i(2 - \delta_{m_y} 0) \frac{k_0}{\ell_y} (\zeta_{y_0} + \zeta_{y_1}) + i(2 - \delta_{m_z} 0) \frac{k_0}{\ell_z} (\zeta_{z_0} + \zeta_{z_1}). \end{aligned} \tag{9.53}$$

Finally, by noting that

$$\begin{aligned} ik_0 \frac{2 - \delta_{m_x} 0}{\ell_x} (\zeta_{x_0} + \zeta_{x_1}) = \\ ik_0 \int_0^{\ell_y} \int_0^{\ell_z} [\zeta_{x_0} \psi_m^2(x=0, y, z, \omega) + \zeta_{x_1} \psi_m^2(x=\ell_x, y, z, \omega)] dz dy, \end{aligned} \tag{9.54}$$

equation (9.53) becomes

$$\chi_m^2 = k_m^2 + ik_0 \iint_S \zeta \psi_m^2 dS, \tag{9.55}$$

where  $S$  denotes the total surface area of the wall. As was expected, equation (9.55) is identical to equation (9.47).

Note 1: when an index is null, the effects of the associated wall impedances ( $\zeta_{x_0}$  and  $\zeta_{x_1}$  for  $m_x = 0$ , for example) are reduced by a factor of 2. In other words, the influence of the walls is reduced to half for parallel particle motions.

Note 2: the eigenfunctions (9.49) are not exactly orthogonal. A simple calculation shows that the integral over the entire domain (inner product)

$$\iiint_D \psi_m(\vec{r}, \omega) \psi_n(\vec{r}, \omega) d\vec{r},$$

is a quantity the order of magnitude of which is greater than or equal to  $\zeta_{x_i}^{3/2}$ ,  $\zeta_{y_i}^{3/2}$ ,  $\zeta_{z_i}^{3/2}$  with  $(i = 0, 1)$  when  $m \neq n$  and is equal to a term the order of magnitude of which is greater or equal to  $\zeta_{x_i}$ ,  $\zeta_{y_i}$ ,  $\zeta_{z_i}$  for  $m = n$ .

### 9.3. Problems with high modal density: statistically quasi-uniform acoustic fields

#### 9.3.1. Distribution of the resonance frequencies of a rectangular cavity with perfectly rigid walls

##### 9.3.1.1. Classification of the modes

If a source radiates within a given frequency range, all the modes of the closed space of which the resonance frequencies are roughly within this frequency range are excited while the other modes are barely contributing to the pressure field in the cavity. It is therefore important to know the number of resonance frequencies contained within this frequency range. The knowledge of the “modal density” is necessary to predict the conditions in which the acoustic pressure field is statistically uniform.

Given the regularity of a parallelepipedic cavity with perfectly rigid walls, such closed spaces are unfavorable to pressure field uniformity. Consequently, the numbers of modes is an important quantity.

The resonance frequencies are given by

$$v_n^2 = \left( \frac{k_n c_0}{2\pi} \right)^2 = \left( \frac{n_x c_0}{2\ell_x} \right)^2 + \left( \frac{n_y c_0}{2\ell_y} \right)^2 + \left( \frac{n_z c_0}{2\ell_z} \right)^2. \quad (9.56)$$

Figure 9.4 presents the strictly positive eighth of the frequency space where the points of intersections of the mesh lines represent the resonance frequencies of the closed space considered. The length of a segment joining the origin to any given “resonance point” is equal to the associated resonance frequency. The angles made by this segment with the three principal axes are the angles between the three

adjacent walls of the cavity and the direction of propagation of the plane waves generating the considered mode.

It is clear from Figure 9.4 that the angular distribution is less uniform at low frequencies. Consequently, in a “long” room, at low frequencies, the absorption of a material depends highly on the surface of the material. Then, in addition to the notion of number of resonance frequencies within a given frequency range, it is useful to introduce a classification of the modes that, even if qualitative, leads to a characterization of the diffusion of sound energy within a closed space.

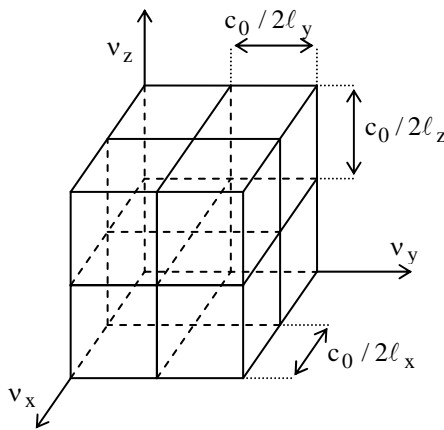

**Figure 9.4.** Frequency space: the resonance frequencies are represented by the intersection points between the mesh lines

There are four categories of modes: i) the uniform mode corresponding to three null indexes “ $n$ ”; ii) the axial modes corresponding to two null indexes (for an axial mode about the  $x$  axis:  $n_y = n_z = 0$ , for an axial mode about the  $y$  axis:  $n_x = n_z = 0$ , for an axial mode about the  $z$  axis:  $n_x = n_y = 0$ ); iii) the tangential modes (parallel to the  $yz$  plane if  $n_x = 0$ , parallel to the  $xz$  plane if  $n_y = 0$  and parallel to the  $yz$  plane if  $n_x = 0$ ); and finally iv) the oblique modes where none of the indexes ( $n_x, n_y, n_z$ ) is null.

The factor  $(2 - \delta_{m0})$  in equation (9.53) shows that for a given distribution of the materials on the cavity walls, the axial modes present the smallest absorption coefficient while the oblique modes present the greatest. The rapid decay of the amplitude of oblique modes is then followed by the decay of tangential and finally axial modes.

### 9.3.1.2. Number of modes in each category

In the frequency frame (Figure 9.4), the volume of one cell is given by

$$\frac{c_0^3}{8\ell_x\ell_y\ell_z} = \frac{c_0^3}{8V}. \quad (9.57)$$

The number of axial modes about the  $x$ -axis which resonance frequencies are less than  $\nu$  is

$$N_{ax} \approx \frac{\nu}{c_0/(2\ell_x)} \approx \frac{2\ell_x}{c_0} \nu, \quad (9.58)$$

and the total number of axial modes which resonance frequencies are less than  $\nu$  is

$$N_a = N_{ax} + N_{ay} + N_{az} \approx \frac{L}{2c_0} \nu, \quad (9.59)$$

where  $L = 4(\ell_x + \ell_y + \ell_z)$  denotes the total length of the edges of the parallelepipedic cavity in Figure 9.3.

The number of axial modes, which resonance frequencies are between  $\nu$  and,  $\nu + d\nu$  is obtained by differentiating equations (9.58) and (9.59) with respect to  $\nu$

$$dN_{ax} \approx \frac{2\ell_x}{c_0} d\nu \text{ and } dN_a \approx \frac{L}{2c_0} d\nu. \quad (9.60)$$

The number of tangential modes parallel to the  $(y, z)$  plane, denoted  $N_{tyz}$ , is given by the ratio of the “volume” occupied by the quarter of a disk of “thickness”  $c_0/2\ell_x$ , i.e.  $(\pi\nu^2/4)(c_0/2\ell_x)$ , to the “volume” of a cell  $(c_0^3/8V)$  minus the contribution of the axial modes contained in this volume  $(1/2)(2\ell_y + 2\ell_z)\nu/c_0$  (the factor  $1/2$  avoids counting all the modes of which corresponding points belong to the intersection of two planes, the other half being included when numbering the other tangential modes). Thus

$$N_{tyz} \approx \frac{1}{4}\pi\nu^2 \frac{c_0}{2\ell_x} \frac{8V}{c_0^3} - (\ell_y + \ell_z) \frac{\nu}{c_0} \approx \frac{\pi\nu^2}{c_0^2} \ell_y \ell_z - \frac{\nu}{c_0} (\ell_y + \ell_z), \quad (9.61)$$

$$N_t \approx N_{tyz} + N_{tzx} + N_{txy} \approx \frac{\pi\nu^2}{2c_0^2} A - \frac{\nu}{2c_0} L, \quad (9.62)$$

where  $A = 2(\ell_x \ell_y + \ell_y \ell_z + \ell_z \ell_x)$  denotes the total wall area of the cavity.

The number of tangential modes, which resonance frequencies are between  $\nu$  and,  $\nu + d\nu$ , is then

$$dN_{\text{tyz}} = \left[ \frac{2\pi\nu}{c_0^2} \ell_y \ell_z - \frac{1}{c_0} (\ell_y + \ell_z) \right] d\nu, \quad (9.63)$$

$$dN_t = dN_{\text{tyz}} + dN_{\text{tzx}} + dN_{\text{txy}} = \left[ \frac{\pi\nu}{c_0^2} A - \frac{L}{2c_0} \right] d\nu. \quad (9.64)$$

Finally, the number  $N_0$  of oblique modes, which frequency is less than  $\nu$ , is the ratio of the “volume” of an eighth of a sphere to the “volume” of a mesh element minus the contribution of any other type of mode

$$N_0 = \frac{4\pi\nu^3 V}{3c_0^3} - \frac{\pi\nu^2 A}{4c_0^2} + \frac{\nu L}{8c_0}, \quad (9.65)$$

and consequently

$$dN_0 = \left[ \frac{4\pi\nu^2 V}{c_0^3} - \frac{\pi\nu A}{2c_0^2} + \frac{L}{8c_0} \right] d\nu. \quad (9.66)$$

The total number of modes, which resonance frequencies are between  $\nu$  and  $\nu + d\nu$ , is

$$dN \approx \left[ \frac{4\pi\nu^2 V}{c_0^3} - \frac{\pi\nu A}{2c_0^2} + \frac{L}{8c_0} \right] d\nu. \quad (9.67)$$

At high frequencies, an approximation of equation (9.67) is

$$dN \approx \frac{4\pi\nu^2 V}{c_0^3} d\nu. \quad (9.68)$$

Equation (9.68) shows that the average number of excited resonances within a given frequency range  $d\nu$  increases with the square of the frequency. This explains why modal theory and numerical methods are limited to low frequencies.

### 9.3.1.3. “Response” of a parallelepipedic room to a short periodic signal

Let a source emit a signal of frequency  $\nu_0$  during a short period of time  $\Delta t$  (Figure 9.5).

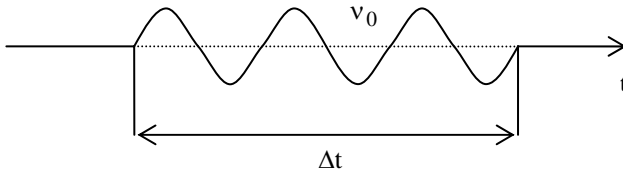

**Figure 9.5.** short periodic signals of duration  $\Delta t$  and frequency  $\nu_0$

According to the fundamental properties of the Fourier transform, such impulse signal can only be transmitted without serious distortion if at least the frequency interval  $(\nu_0 - 1/2\Delta t, \nu_0 + 1/2\Delta t)$  is “properly” transmitted. Assuming that this frequency range is transmitted to all points in the room if at least ten resonance frequencies within this interval are excited (to ensure uniformity of the energy distribution) means that, according to equation (9.68), there exists a limit frequency  $\nu_L$  above which this condition is not fulfilled. For example, the emission of a semiquaver ( $\Delta t \approx 0.1s$ ) in a  $160\text{ m}^3$  room is only “properly” heard if the frequency of the fundamental is greater than 140Hz (i.e. approximately E1).

Note: the greater the symmetry of a room, the greater the degeneracy of the modes. In other words, for highly symmetrical rooms, the number of stationary waves of different quanta  $(n_x, n_y, n_z)$  with the same eigenvalue  $k_n$  is large. Consequently, the greater the gap between adjacent resonance frequencies, the less attractive the room response appears to the musician. A cubic room, for example, presents a sound-energy distribution less uniform than a rectangular room of the same volume and is therefore less desirable.

### 9.3.2. Steady state sound field at “high” frequencies

“High” frequencies are understood to be frequencies the wavelengths of which are relatively small compared to the dimensions of the cavity. This condition can, for example, be expressed as  $\lambda < v^{1/3}/3$ . At these frequencies, modal theory still holds, but in practice its efficiency is reduced by a slow convergence of the modal series. At these frequencies, oblique modes are predominant (in higher numbers), high in density (the difference between resonance frequencies is much smaller than the width of the resonance peaks; see Figure 9.1), and correspond to rather complex



wave trajectories. Consequently, the acoustic field is relatively uniform allowing the use of geometrical and statistical models as a first approximation. The object of this section is to provide the assumptions necessary to obtain relatively simple results using modal theory at high frequencies.

The modal analysis has been presented in the case of a parallelepipedic cavity, but it is very difficult to implement with complex geometries. Rectangular rooms, being unfavorable to spatial and frequency uniformity, are nevertheless a good starting point for the study of acoustic fields in complex rooms. Moreover, equation (9.68), which gives the approximate number of modes between  $\nu$  and  $\nu + d\nu$  in rectangular rooms at high frequencies, remains correct for any given room shape, while axial and tangential modes are non-existent in complex geometries.

9.3.2.1. *Spatial mean and time average of the acoustic pressure at high frequencies*

9.3.2.1.1. Mean quadratic pressure

The strength of a punctual source emitting at the angular frequency  $\omega$  is

$$q(\vec{r}_0, t) = Q_\omega \delta(\vec{r} - \vec{r}_0) \cos(\omega t), \tag{9.69}$$

and its Fourier transform is

$$q(\vec{r}_0, \omega') = 2\pi Q_\omega \delta(\vec{r} - \vec{r}_0) \frac{1}{2} [\delta(\omega' - \omega) + \delta(\omega' + \omega)]. \tag{9.70}$$

The real part of the resulting sound pressure field, written as in equation (9.34) using the Green's function of equation (9.46), is

$$p(\vec{r}, t) = \frac{1}{2\pi} \int_{-\infty}^{\infty} i\rho_0\omega' 2\pi Q_\omega \frac{1}{2} [\delta(\omega' - \omega) + \delta(\omega' + \omega)] \sum_m \frac{\Psi_m(\vec{r}_0, \omega') \Psi_m(\vec{r}, \omega')}{\chi_m^2(\omega') - \omega'^2 / c^2} e^{i\omega' t} d\omega'. \tag{9.71}$$

The expression of the sound pressure field is therefore

$$p(\vec{r}, t) = p(\vec{r}, \omega) \frac{e^{i\omega t}}{2} + p(\vec{r}, -\omega) \frac{e^{-i\omega t}}{2},$$

with  $p(\vec{r}, \omega) = i\rho_0\omega Q_\omega \sum_m \frac{\Psi_m(\vec{r}_0, \omega) \Psi_m(\vec{r}, \omega)}{\chi_m^2 - \omega^2 / c^2}, \tag{9.72}$

and, since the Fourier transform of  $p$  is an hermitian (section 9.2.1.1),

$$p(\vec{r}, -\omega) = p^*(\vec{r}, \omega). \quad (9.73)$$

This above property leads to the following form of solution

$$p(\vec{r}, t) = |p(\vec{r}, \omega)| \cos(\omega t + \theta), \quad (9.74)$$

where the complex amplitude  $p(\vec{r}, \omega) = |p(\vec{r}, \omega)| e^{i\theta}$  is the solution to the problem in the Fourier domain.

Thus, the root mean square value of the pressure  $p_{\text{rms}}$  measured by a microphone is related in steady state to the solution in the Fourier domain by

$$p_{\text{rms}}^2 = \frac{1}{T} \int_{-T/2}^{T/2} |p(\vec{r}, t)|^2 dt = \frac{|p(\vec{r}, \omega)|^2}{2}, \quad (9.75)$$

and the mean value  $\langle p_{\text{rms}}^2 \rangle_r$  of the quadratic pressure calculated over the entire room is

$$\langle p_{\text{rms}}^2 \rangle_r = \frac{1}{V} \iiint_V p_{\text{rms}}^2 dV = \frac{1}{2V} \iiint_V |p(\vec{r}, \omega)|^2 dV. \quad (9.76)$$

In the case of a non-sinusoidal signal, equation (9.76) can be generalized using Parseval's inequality

$$\left\langle \int_{-\infty}^{\infty} |p(\vec{r}, t)|^2 dt \right\rangle_r = \int_{-\infty}^{\infty} \langle |p(\vec{r}, t)|^2 \rangle_r dt = \frac{1}{2\pi} \int_{-\infty}^{\infty} \langle |p(\vec{r}, \omega)|^2 \rangle_r d\omega, \quad (9.77)$$

leading to a relationship between the mean quadratic pressure (mean value with respect to the volume) and the power spectrum density  $|p(\vec{r}, \omega)|^2$  of the signal

$$\left\langle \frac{1}{T} \int_{-T/2}^{T/2} |p(\vec{r}, t)|^2 dt \right\rangle_r = \left\langle \frac{1}{2\pi T} \int_{-T/2}^{T/2} |p(\vec{r}, \omega)|^2 d\omega \right\rangle_r, \quad (9.78)$$

where, for a periodic signal, the expansion coefficients  $C_n$  for the pressure can be introduced, giving

$$\left\langle \frac{1}{T} \int_{-T/2}^{T/2} |p(\vec{r}, t)|^2 dt \right\rangle_r = \left\langle \sum_{n=-\infty}^{\infty} |C_n|^2 \right\rangle_r. \quad (9.79)$$

## 9.3.2.1.2. Complex eigenvalues

The complex eigenvalues are given by equation (9.47) as

$$\chi_m^2 \approx k_m^2 + ik_0 \left( \frac{2\gamma_m^0}{c_0} \right), \quad (9.80)$$

where the wavenumbers  $k_m$  denote the eigenvalues of the problem associated with the rectangular room that has perfectly rigid walls, and  $\chi_m$  denotes those of the room that does not have perfectly reflecting walls.

In the case of section 9.2.4.3 (rectangular cavity with weakly absorbing walls),  $\chi_m^2$  is given by equation (9.53) and, denoting  $\xi_{x_i} = \text{Re}[\zeta_{x_i}]$ , is

$$\chi_m^2 \approx k_m^2 + ik_0 \left[ \left( 2 - \delta_{m_x,0} \right) \left( \xi_{x_0} + \xi_{x_1} \right) \frac{\ell_y \ell_z}{V} + \dots \right], \quad (9.81)$$

with  $V = \ell_x \ell_y \ell_z$ .

The factor

$$a_m = \frac{8V}{c_0} \gamma_m^0 \approx 4 \left[ \left( 2 - \delta_{m_x,0} \right) \left( \xi_{x_0} + \xi_{x_1} \right) \ell_y \ell_z + \dots \right], \quad (9.82)$$

can also be written, for  $m_x, m_y, m_z \neq 0$  (oblique modes) and denoting  $S_i$  the area of the  $i^{\text{th}}$  wall, as

$$a_m = \frac{8V}{c_0} \gamma_m^0 \approx \sum_i 8 \xi_i S_i. \quad (9.83)$$

According to the expression of the coefficient of absorption (in terms of energy) of a unit surface in random incidence (equation (4.51)),  $\alpha_i = 8\xi_i$ , this coefficient represents the energy absorption by the walls in random incidence.

## 9.3.2.1.3. Mean quadratic pressure in the room

The substitution of the expression (9.80) of  $\chi_m^2$  and  $k^2 = k_0^2(1 - ik_0 \ell_{vh})$ , which considers the visco-thermal dissipation during the propagation, into expression (9.72) of the pressure  $p(\vec{r}, t)$  gives the mean value of the quadratic pressure in the room (equations (9.73) to (9.76)) as

$$\begin{aligned} \left\langle P_{\text{rms}}^2 \right\rangle_{\mathbf{r}} &= \frac{1}{2} \left\langle |p_{\omega}(\vec{\mathbf{r}})|^2 \right\rangle_{\mathbf{r}} = \frac{1}{2} \left\langle p_{\omega} p_{\omega}^* \right\rangle_{\mathbf{r}} \\ &= \frac{\rho_0^2 \omega^2 Q_{\omega} Q_{\omega}^*}{2} \sum_{m,n} \frac{\psi_n(\vec{\mathbf{r}}_0, \omega) \psi_m^*(\vec{\mathbf{r}}_0, \omega) \left\langle \psi_n(\vec{\mathbf{r}}, \omega) \psi_m^*(\vec{\mathbf{r}}, \omega) \right\rangle_{\mathbf{r}}}{\left[ k_m^2 - k_0^2 + ik_0(2\gamma_m/c_0) \right] \left[ k_n^2 - k_0^2 + ik_0(2\gamma_n/c_0) \right]}, \end{aligned} \quad (9.84)$$

where  $\gamma_n$  is expressed as in equations (9.28) and (9.29).

The orthogonality relationship

$$\left\langle \psi_n(\vec{\mathbf{r}}, \omega) \psi_m^*(\vec{\mathbf{r}}, \omega) \right\rangle_{\mathbf{r}} \approx \delta_{nm},$$

reduces equation (9.84) to

$$\left\langle P_{\text{rms}}^2 \right\rangle_{\mathbf{r}} = \frac{1}{2} \left( \frac{\omega \rho_0}{V} \right)^2 |Q_{\omega}|^2 \sum_n \frac{|\psi_n(\vec{\mathbf{r}}_0, \omega)|^2}{\left( k_n^2 - k_0^2 \right)^2 + \left( 2k_0 \gamma_n / c_0 \right)^2}. \quad (9.85)$$

This result makes sense only at high frequencies. Indeed, at low frequencies, where the number of excited resonance frequencies is small, the notion of a mean of the pressure makes no sense.

Equation (9.85) is a good approximation of the mean quadratic pressure measured at a given point, but only if the measurement is carried out at least half a wavelength away from the wall and not too close to the source where the near-field is predominant.

Going even further with the approximation, the factor  $|\psi_n(\vec{\mathbf{r}}_0, \omega)|^2$  can be replaced by its mean value over the index  $n$  (mean value calculated over all modes) at the point  $\vec{\mathbf{r}}_0$ . Given that the frequency of the excitation is assumed high, the first modes contribute very little and, consequently, the calculation of the mean value can be restricted to the oblique modes where the resonance frequencies of which are close to  $\omega$ .

By assuming that  $|\psi_n(\vec{\mathbf{r}}_0, \omega)|^2$  behaves as eight times the square of the product of three cosines functions (equations (9.49) and (9.51)), its mean value is equal to 1 if none of the arguments of the cosines is close to  $n\pi$ , in other words, if the source is at least  $\lambda/2$  away from the walls. The same factor equals 2 if the source is close to the walls, 4 if close to an edge of the cavity and 8 if close to a corner. Thus, an approximation of the quantity

$$E(\vec{\mathbf{r}}_0) = \left\langle |\psi_n(\vec{\mathbf{r}}_0, \omega)|^2 \right\rangle_n, \quad (9.86)$$

mean over all modes at a given point  $\bar{r}_0$  and frequency  $\omega$  is

- $E(\bar{r}_0) \approx 1$  if the source is away from the walls,
- $E(\bar{r}_0) \approx 2$  if the source is close to a wall,
- $E(\bar{r}_0) \approx 4$  if the source is close to an edge,
- $E(\bar{r}_0) \approx 8$  if the source is close to a corner.

The mean quadratic pressure calculated over the entire volume of the room then becomes

$$\langle p_{\text{rms}}^2 \rangle_r \approx \frac{1}{2} \left( \frac{\omega p_0}{V} \right)^2 |Q_\omega|^2 E(\bar{r}_0) \sum_n \frac{1}{\left( k_n^2 - k_0^2 \right)^2 + \left( 2k_0 \gamma_n / c_0 \right)^2}. \tag{9.87}$$

By using the expression (9.68) of the number of eigenvalues within the frequency range  $(\nu, \nu + d\nu)$  to which corresponds the wavenumber range  $(\eta, \eta + d\eta)$ ,

$$dN = \frac{4\pi\nu^2 V}{c_0^3} d\nu = \frac{V}{2\pi^2} \eta^2 d\eta,$$

the discrete sum over the index  $n$  of equation (9.87) can be replaced by a continuous sum over the range  $d\eta$ ,

$$\sum_n \frac{1}{\left( k_n^2 - k_0^2 \right)^2 + \left( 2k_0 \gamma_n / c_0 \right)^2} \approx \frac{V}{2\pi^2} \int_0^\infty \frac{\eta^2 d\eta}{\left( \eta^2 - k_0^2 \right)^2 + \left( 2k_0 \gamma_\eta / c_0 \right)^2}, \tag{9.88}$$

where  $\gamma_\eta$  denotes the mean value of  $\gamma_n$  over the associated frequency range  $\gamma_n$ .

The integrand in equation (9.88) has important values only within the range where  $\eta^2$  is close to  $k_0^2$ . The lower integration bound (zero) can therefore be replaced by  $-\infty$ . The integration by the method of residues leads directly to a result which introduces trigonometric functions, the approximated value of which, considering that  $(2k_0 \gamma_n / c_0) \ll k_0^2$ , is

$$\frac{c_0 V}{8\pi\gamma}, \tag{9.89}$$

where  $\gamma$  denotes the mean value of  $\gamma_\eta$  over  $\eta$ .

The substitution of equation (9.89) into equation (9.87) gives, finally, the approximated expression of the spatial mean of the quadratic pressure at high frequencies

$$\left\langle p_{\text{rms}}^2 \right\rangle_r \approx \frac{\rho_0^2 \omega^2 c_0}{16\pi V \gamma} \left| Q_\omega \right|^2 E(\bar{\mathbf{r}}_0). \quad (9.90)$$

9.3.2.1.4. Domain of validity of the approximated mean quadratic pressure (equation (9.90))

Above a certain frequency, the distance on the  $\omega$ -axis between excited resonance frequencies becomes very short compared to the width of these resonances (Figure 9.1). The wavelength is then shorter than a quarter of the smallest dimension of the room, and the number of oblique modes per frequency band considered is significantly greater than the number of axial and tangential modes. It is therefore appropriate to use the approximated expression (9.68) to express the total number of resonances in the frequency band  $dv$  as

$$dN \approx \frac{4\pi v^2 V}{c_0^3} dv = \frac{\omega^2 V}{2\pi^2 c_0^3} d\omega = \frac{k^2 V}{2\pi^2} dk_0. \quad (9.91)$$

Thus, the average gap between two adjacent resonances can be written as

$$\frac{dv}{dN} \approx \frac{c_0^3}{4\pi v^2 V}, \quad (9.92)$$

and when the average gap is (for example) smaller than an eighth of the mean width of the resonance peaks about the  $\omega$ -axis, thus smaller than

$$\frac{1}{8} \frac{2\gamma}{2\pi} = \frac{\gamma}{8\pi}, \quad (9.93)$$

( $\gamma$  denoting an average value of  $\gamma_n$  about the  $\omega$  axis), the room response can be considered statistically uniform.

This condition is written as

$$\frac{c_0^3}{4\pi v^2 V} < \frac{\gamma}{8\pi} \quad \text{or} \quad v > \sqrt{\frac{2c_0^3}{\gamma V}}. \quad (9.94)$$

According to the definitions and results presented in the next section (that are accepted from now on in this discussion, the reverberation time  $T$  is approximately equal to  $(6.91/\gamma)$  for the frequencies satisfying the condition (9.94). Accordingly, equation (9.94) becomes

$$\nu > \sqrt{\frac{2c_0^3 T}{6.9 V}} . \quad (9.95)$$

If the average gap between resonance frequencies is smaller than the third of the mean width of the resonance peaks, equation (9.95) becomes

$$\nu > 2000 \sqrt{\frac{T}{V}} . \quad (9.96)$$

The right-hand side term represents the limit frequency called Shroeder's frequency. Equation (9.96) gives, for a  $160 \text{ m}^3$  room with a reverberation time of 1 second,  $\nu = 160 \text{ Hz}$ . This result is in agreement with the one obtained in section 9.3.1.3.

To conclude, the approximation (9.90) is valid only if the conditions given by equations (9.94) to (9.96) are fulfilled.

### 9.3.3. Acoustic field in transient regime at high frequencies

The mean quadratic pressure at a given point in the room and for a given position of the source, after extinction of the source, can be calculated as in the previous steady-state case, if the acoustic field is assumed roughly uniform. According to the results obtained in section 9.2.4.2, the reverberant field can always be written, if the source stops emitting at  $t = 0$ , as

$$p(\vec{r}, t) = \sum_m B_m e^{-\gamma_m t} \cos(\omega_m t + \Omega_m) , \quad (9.97)$$

where  $B_m$  and  $\Omega_m$  depend on the characteristics of the emitted field before extinction of the source, on the position of the source and receiving point, and on the characteristics of the room.

Unlike the calculation of the approximated steady-state field at high frequencies, the object of this section is to find the approximated expression of the field under a transient regime.

The signal considered is the mean quadratic of the pressure  $p(\vec{r}, t)$ , time averaged over at least a period of this signal. This integration time is sufficiently short so as to let us assume that the decay factor  $\exp(-\gamma_m t)$  is quasi-constant over the integration time. Consequently, the time average of  $p(\vec{r}, t)$  is reduced to that of the cosine function, so that equation (9.97) leads to

$$p_{\text{rms}}^2 \approx \frac{1}{2} \sum_m |B_m|^2 e^{-2\gamma_m t}. \quad (9.98)$$

The coefficients  $|B_m|^2$  contain the square of the modulus of the eigenfunctions  $\psi_m$ . Thus, the mean quadratic pressure  $p_{\text{rms}}^2$  over the entire room volume introduces the factor:

$$\left\langle |\psi_m(\vec{r}, \omega)|^2 \right\rangle_r = 1, \quad (9.99)$$

and the mean value over all modes introduces the factor

$$\left\langle |\psi_m(\vec{r}_0, \omega)|^2 \right\rangle_r = E(\vec{r}_0), \quad (9.100)$$

where  $E(\vec{r}_0)$  is defined by equation (9.86). From now on, the source is assumed relatively far from any wall, so that  $E(\vec{r}_0) = 1$ .

Thus, the factor  $|B_m|^2$  can be expressed independently of the index  $m$ , then noted  $\left\langle |B|^2 \right\rangle_r$ , leading to

$$\left\langle p_{\text{rms}}^2 \right\rangle_r \approx \frac{1}{2} \left\langle |B|^2 \right\rangle_r \sum_m e^{-2\gamma_m t}. \quad (9.101)$$

As in the previous section, to estimate the acoustic field in the high frequency range, the sum over all modes introduces categories of modes in each frequency band between  $(k_0 - dk_0/2, k_0 + dk_0/2)$  translated into many terms (1 uniform, 3 axial, 3 tangential and 1 oblique modes). Each of these factors includes the number of modes of the considered type (section 9.3.1.2). This is made possible by the assumption that to each type of mode is associated one attenuation factor  $\gamma_m$  given by equation (9.82).



It is not necessary to detail the expressions resulting from these approximations to understand that the decay curves (in the time domain after extinction of the source) present some singularities, in particular when the energy of the rapidly-decaying modes (oblique) reaches a level inferior to the energy of the slowly-decaying ones, the slope of the decay curve decreases.

If the irregularities of the surface of the cavity walls are significant so that each mode is actually a more or less complex combination of oblique modes, the values of the modal attenuation factor  $\gamma_m$ , in the given frequency band, are close enough for the expression (equation (9.101)) of the mean quadratic pressure to be

$$\langle p_{\text{rms}}^2 \rangle_r \approx \frac{1}{2} \langle |B|^2 \rangle_r N_0 e^{-2\gamma t}, \quad (9.102)$$

where  $N_0$  denotes the number of oblique modes to consider and where the dissipation factor  $\gamma$  is given, for a rectangular room, by equations (9.82) and (9.83), as

$$\gamma = \frac{c_0 a}{8V} \approx \frac{c_0}{8V} \sum_i 8\xi_i S_i, \quad (9.103)$$

the index  $i = 1, 2, \dots, 6$  denoting the 6 walls of the room,  $V$  its volume and  $\xi_i$  the real part of the specific admittance of each wall.

Finally, in terms of energy, the decay law sought is written as

$$I = I_0 e^{-2\gamma t} = I_0 e^{-\frac{ac}{4V} t}, \quad (9.104)$$

or, in terms of sound levels, as

$$L = L_0 + \frac{10}{2.302} (-2\gamma t) = L_0 + \frac{10}{2.302} \left( -\frac{ac}{4V} t \right), \quad (9.105)$$

with  $L_0 = L(t = 0) = 10 \log_{10}(I_0)$ .

The reverberation time  $T$  needed for the level to decrease by 60 dB is written  $L - L_0 = -60$ , or

$$T = \frac{6.91}{\gamma} = 0.16 \frac{V}{a}. \quad (9.106)$$

This is Sabine's formula where  $V$  is expressed in cubic meters,  $a$  in square meters and the quantity 0.16 is the numerical value of a reciprocal of a speed. The conditions of application of this relationship require a quasi-uniform sound field (diffused field) and, consequently, that the frequencies considered are relatively high and/or that the shape of the room and distribution of the materials on the wall are random. From these hypotheses, statistical acoustics leads very simply to the same results and interpretations as equations (9.106) and (9.90) as will be shown in the following section.

## 9.4. Statistical analysis of diffused fields

The modal theory has delivered some simple results by means of a number of assumptions based on a degree of uniformity of the sound field. A simpler theory gives the same results and interpretation. The following theory is valid only at "high" frequencies and the results are based on a statistical description of the mean sound intensity.

### 9.4.1. Characteristics of a diffused field

Besides the hypothesis of high frequencies, the dimensions, shapes and nature of the walls are assumed such that the acoustic intensity in the room is considered uniform and isotropic. To fulfill these assumptions, the dimensions of the room must be large; the geometry must present a minimum of symmetry and the walls must be weakly absorbing. A complex geometry minimizes the existence of axial and tangential modes, but favors the oblique ones and, therefore, the diffusivity of the sound field. The large dimensions and high-reflection coefficients of the walls favor highly energetic steady-state levels and long reverberation time in transient.

If all these conditions are fulfilled, the acoustic field at a given point of the room can be considered as resulting from the plane waves "coming" from the walls. Even though the waves have the same probability of occurrence, each one is characterized by its direction (defined by the angles  $\theta$  and  $\phi$ ), its amplitude  $A(\vec{r}|\theta, \phi)$  (expressed per unit of solid angle), and its intensity  $|A(\vec{r}|\theta, \phi)|^2 / (2\rho_0 c_0)$ .

In other words, the total pressure at  $\vec{r}$  is written as a superposition of plane waves

$$p(\vec{r}) = \int_0^{2\pi} d\phi \int_0^\pi A(\vec{r}|\theta, \phi) e^{-i\vec{k}\cdot\vec{r} + i\omega t} \sin\theta d\theta, \quad (9.107)$$

the energy density at  $\vec{r}$  as the sum of the individual energy densities

$$W(\vec{r}) = \frac{1}{2\rho_0 c_0^2} \int_0^{2\pi} d\phi \int_0^\pi |A(\vec{r}|\theta, \phi)|^2 \sin\theta d\theta = \frac{p_{\text{rms}}^2(\vec{r})}{\rho_0 c_0^2}, \quad (9.108)$$

and the energy flow through the surface perpendicular to a given direction (the mean acoustic intensity in one direction) as the sum of the individual intensities in half a solid angle

$$I(\vec{r}) = \frac{1}{2\rho_0 c_0} \int_0^{2\pi} d\phi \int_0^{\pi/2} |A(\vec{r}|\theta, \phi)|^2 \cos\theta \sin\theta d\theta. \quad (9.109)$$

By hypothesis, the plane waves are randomly distributed in direction and phase (in accordance with the previous assumptions), the amplitude  $A(\vec{r}|\theta, \phi)$  is then assumed independent of  $\vec{r}$ ,  $\theta$  and  $\phi$ . Equations (9.107) to (9.109) lead to

$$W = 2\pi \frac{A^2}{\rho_0 c_0^2} = \frac{p_{\text{rms}}^2}{2\rho_0 c_0^2}, \quad (9.110)$$

and

$$I = \pi \frac{A^2}{2\rho_0 c_0} = \frac{p_{\text{rms}}^2}{4\rho_0 c_0}, \quad (9.111)$$

$$\text{thus } 4I = c_0 W. \quad (9.112)$$

#### 9.4.2. Energy conservation law in rooms

If the random incidence absorption coefficient per unit of area (in terms of energy) of an element of wall at  $\vec{r}_s$  is denoted  $\alpha(\vec{r}_s)$  (4.51), the power absorbed by the walls by virtue of the aforementioned hypotheses is

$$\iint_{S_0} \alpha(\vec{r}_s) I(\vec{r}_s) dS = I \iint_{S_0} \alpha(\vec{r}_s) dS = aI, \quad (9.113)$$

where  $a$  defines the total absorption of the walls and is commonly called the “equivalent absorption area of the room” and is, as a first approximation, the equivalent to the coefficients  $a_n$  in equation (9.83) or to the coefficient  $a$  in equation (9.103).

The energy conservation law is expressed by writing that the difference  $[\rho_0(t) - aI(t)]$  between the power  $\rho_0(t)$  emitted by the sources in the room and the power  $aI(t)$  absorbed by the wall is equal to the variation per unit of time of the total acoustic energy  $VW = 4VI/c_0$  (9.112):

$$\frac{d}{dt}[4VI/c_0] = \rho_0(t) - aI(t). \quad (9.114)$$

This equation is solved by the classic method, and leads to

$$I(t) = \frac{c_0}{4V} e^{-\frac{ac_0}{4V}t} \int_{-\infty}^t e^{\frac{ac_0}{4V}\tau} \rho_0(\tau) d\tau. \quad (9.115)$$

If the emitted power  $\rho_0$  varies slowly in time (its variation can be considered negligible during a period of time at least equal to  $4V/(ac_0)$ ), the factor  $\rho_0(\tau)$  can be considered, during a given period of time, independent of  $\tau$  in the integral, giving

$$I(t) \approx \frac{\rho_0(t)}{a}. \quad (9.116)$$

If the extinction of the source, satisfying the previous condition, occurs at  $t = 0$ , then for  $t > 0$

$$I(t) = \frac{c_0}{4V} e^{-\frac{ac_0}{4V}t} \int_{-\infty}^t e^{\frac{ac_0}{4V}\tau} \rho_0(\tau) d\tau \approx e^{-\frac{ac_0}{4V}t} \frac{\rho_0(0)}{a},$$

or  $I(t) = I(0)e^{-\frac{ac_0}{4V}t}$ , (9.117)

or, using the decibel scale,

$$L = L_0 - 4.34 \frac{ac_0}{4V} t. \quad (9.118)$$

The reverberation time  $T$  associated with a decrease of 60 dB is given by equation (9.118), where  $L - L_0 = -60$ , and is

$$T = 0.16 \frac{V}{a}. \quad (9.119)$$

Sabine's formula has been obtained in the same form as in the previous section.

Note: the measurement of the reverberation time gives the absorption coefficient  $\alpha_1$  (in terms of energy) of a material in diffused field. Indeed, the reverberation time  $T_0$  of the empty room (the walls of which are assumed uniform)

$$T_0 = 0.16 \frac{V}{\alpha_0 S_0},$$

combined with the reverberation time  $T_1$  of the room with the absorbing material covering an area  $S_1$  of the walls

$$T_1 = 0.16 \frac{V}{[\alpha_0(S_0 - S_1) + \alpha_1 S_1]},$$

gives the absorption coefficient sought as

$$\alpha_1 = 0.16 V \left[ \frac{1}{S_0 T_0} + \frac{1}{S_1 T_1} - \frac{1}{S_1 T_0} \right]. \quad (9.120)$$

The coefficient  $\alpha_1$  is generally called Sabine's absorption coefficient. Given the number of assumptions made, it is expected that this result presents a certain degree of discrepancy between the "real" ratio  $\alpha_m$  of the reflected energy flow and the incident energy flow in random incidence. However, in many situations these two quantities agree.

### 9.4.3. Steady-state radiation from a punctual source

In reality, the energy density and isotropy of the energy flow are not uniform everywhere in the room. Very close to the source, which is assumed to be punctual, the acoustic field behaves (in first approximation) as the field radiated by the same source in an infinite space. The intensity in harmonic regime close to the source can then be written as (5.159)

$$I = \frac{|p|^2}{2\rho_0 c_0} = \frac{k^2 \rho_0 c_0 |Q_\omega|^2}{32\pi^2 r^2} = \frac{p_0}{4\pi r^2}, \quad (9.121)$$

while, away from the source (equation (9.116)), it is

$$I \approx \frac{P_0}{a}. \quad (9.122)$$

In practice, the sound intensity is seldom measured directly; it is the mean quadratic pressure that is measured by a microphone. This quantity is simply related to the energy density  $W$  and intensity  $I$  by the following relationships (equations (9.111) and (9.121))

$$- p_{\text{rms}}^2 = \rho_0 c_0 I \text{ for a spherical wave,} \quad (9.123)$$

$$- p_{\text{rms}}^2 = \rho_0 c_0^2 W = 4\rho_0 c_0 I \text{ for a diffused field.} \quad (9.124)$$

Written using the radiated power  $P_0$  and the distance between the source and the receiving point, the relationships immediately above are

$$p_{\text{rms}} = \sqrt{\rho_0 c_0 I} = \sqrt{\rho_0 c_0 \frac{P_0}{4\pi r^2}} \text{ in the near field,} \quad (9.125)$$

$$p_{\text{rms}} = \sqrt{4\rho_0 c_0 I} = \sqrt{4\rho_0 c_0 \frac{P_0}{a}} \text{ in the far field.} \quad (9.126)$$

A criterion of evaluation of the distance  $r_L$  separating the far-field region from the near-field region is obtained equalizing equations (9.125) and (9.126),

$$\frac{\rho_0 c_0 P_0}{4\pi r_L^2} = \frac{4\rho_0 c_0 P_0}{a},$$

$$\text{thus } r_L \approx \sqrt{\frac{a}{50}}. \quad (9.127)$$

Finally, the substitution of the radiated power  $P_0$  (equation (9.121)) into equation (9.126) yields

$$p_{\text{rms}}^2 = \frac{\rho_0^2 \omega^2}{2\pi a} |Q_\omega|^2. \quad (9.128)$$

This result is in agreement with equation (9.90) obtained by modal analysis. The presented statistical theory leads to the same results as those obtained in transient and steady state using modal theory.

#### 9.4.4. Other expressions of the reverberation time

The expressions of the reverberation time presented in this paragraph are alternative expressions to Sabine's formula (9.119). To obtain the first one, the hypothesis of continuous sound energy absorption (of the walls) is replaced by the assumption that a discontinuous process of attenuation of the sound at each reflection on the wall occurs. The sound energy follows a mean free path  $\ell_m$  and is attenuated at each reflection on the walls.

If it is assumed that extinction of the source at  $t = 0$ , and that the intensity in the room at  $t = 0$  is  $I_0$ , and  $t_m = \ell_m / c_0$  is defined as the average period of time between two reflections, then if  $\bar{\alpha}$  denotes the average energy absorption coefficient of the wall and if the attenuation between reflections is described by the factor  $\exp(-\Gamma c_0 t)$ , the sound intensity in the room is

$$I = I_0 e^{-\Gamma c_0 t} (1 - \bar{\alpha})^{t/t_m}. \quad (9.129)$$

The period of time  $t_m$  between reflections is obtained by writing that the energy flow per unit of time received by all walls ( $IS = c_0 WS/4$  (equation (9.111))) is equal to the energy flow through the surface  $S$  per unit of time,

$$\frac{1}{t_m} \iiint_V W dV = \frac{WV}{t_m}, \quad (9.130)$$

where  $1/t_m$  denotes the average number of wall reflections per unit of time for a volume element of energy  $WdV$ . Thus

$$t_m = \frac{4V}{c_0 S} \quad \text{and} \quad \ell_m = \frac{4V}{S}. \quad (9.131)$$

The substitution of equation (9.131) into equation (9.129) gives the intensity at  $t$  as

$$I = I_0 e^{-\Gamma c_0 t} (1 - \bar{\alpha})^{\frac{c_0 S}{4V} t} = I_0 \exp\left(-[4\Gamma V - S \ln(1 - \bar{\alpha})] [c_0 / (4V)] t\right). \quad (9.132)$$

The reverberation time  $T$  is then obtained by writing that  $I_0 / I = 10^6$  (60 dB) or

$$T = \frac{0.16 V}{4\Gamma V - S \ln(1 - \bar{\alpha})}. \quad (9.133)$$

This is Eyring's formula that becomes Sabine's formula if  $\Gamma$  is ignored and by developing the logarithm to the first order.

Both Eyring's and Sabine's formulae make use of the average absorption coefficient. Consequently, their validity is related to the uniformity of the absorbing material distribution.

One way to cope with this limitation is to assume that a given set of rays is reflected on a given surface a number of times proportional to the area of this surface. Thus

$$I = I_0 e^{-\Gamma c_0 t} (1 - \bar{\alpha}_1)^{\frac{S_1 t}{S t_m}} (1 - \bar{\alpha}_2)^{\frac{S_2 t}{S t_m}} \dots (1 - \bar{\alpha}_q)^{\frac{S_q t}{S t_m}}. \quad (9.134)$$

The calculation of the corresponding reverberation time results in the replacement of the factor  $\ln(1 - \bar{\alpha})$  in equation (9.133) by  $\frac{1}{S} \sum_i S_i \ln(1 - \bar{\alpha}_i)$ . This is the so-called Millington-Sette's formula.

The previous expressions of the reverberation time are valid only if a large number of conditions are fulfilled. For example, if one of the  $\alpha_i$  tends to 1, Millington-Sette's formula gives a reverberation time equal to zero! It is, however, common practice to assume small average absorption coefficients (at least significantly smaller than 1), so that the logarithm in equation (9.133) can be expanded into a series to the first order, and small room volume leading back to Sabine's formula.

These expressions of the reverberation time have been modified to increase their accuracy by introducing the probability of having  $(t/t_m)$  reflections after a period of time  $t$  and by assuming a Gaussian distribution of standard deviation  $\sigma$ . Ignoring the absorption of the air, the reverberation time is:

$$T = 0.16 \frac{V}{S \alpha'}, \quad (9.135)$$

$$\text{where } \frac{1}{\alpha'} = \frac{1}{-\ln(1 - \bar{\alpha})} + \frac{\sigma^2}{27.6} \ln(1 - \bar{\alpha}). \quad (9.136)$$

The first term in equation (9.136) is also in Eyring's formula (9.133).

Another expression of the reverberation time was established, and written as the energy received by a surface element  $dS$  is the sum of all contributions of the other



surface elements and that the emission from a surface element depends on the incident energy, the reflection coefficient, and a factor defining the law of diffused reflection (Lambert's law). The resulting expression of  $T$  is the same as in equation (9.135), but with

$$\alpha' = \left[ 1 + \frac{\sigma^2}{2} \ln(1 - \bar{\alpha}) \right] \ln(1 - \bar{\alpha}), \quad (9.137)$$

where  $\sigma^2$  denotes a variance.

There are numerous other studies on reverberation time that are worth a dedicated room-acoustics textbook.

### 9.4.5. Diffused sound fields

#### 9.4.5.1. Definition

Even though intensity measurements are emerging as a dominant technique in acoustics, intensity and radiated power of acoustic sources are still determined, according to most national and international standards, by measurements of mean quadratic pressures (with a single microphone). Consequently, a mathematical model predicting the sound pressure in rooms remains necessary. Such model must: i) provide a simple relationship between intensity, energy density and the measurable acoustic sound pressure; ii) be in agreement (as far as possible) with the real acoustic quantities in rooms; and iii) be robust to any erroneous interpretation.

The model of diffused sound field satisfies the hypotheses of the statistical theory and the aforementioned theories. A diffuse field, as defined in section 9.4.1, assumes that the acoustic field at a given point is the infinite sum of incoherent waves coming from uniformly distributed directions. In rooms such conditions are approximately fulfilled when the acoustic modes are equally excited and are statistically independent. Unfortunately, this is not often the case since the excitation of the modes is never uniform and the absorption of the acoustic modes at the boundaries is selective (close to the source and to the walls, the modes are correlated).

Diffused sound fields are obtained (more precisely, best approximated) by a wise choice of all the factors favorable to high numbers and uniform excitation of the acoustic modes: size, proportions and geometry of the room, nature of the walls, location of the source, largest frequency band of the signal (to maximize the frequency resolution), and addition of static or mobile diffusers. The rooms designed to fulfill all these conditions are called "reverberation chambers".

### 9.4.5.2. Use of diffused fields in acoustic measurements

The appropriate degree of diffusivity of a sound field depends on the nature of the problem considered. For example, to determine the absorption coefficient in a random incidence of a sample, the *ad hoc* degree of diffusivity fulfills the following conditions: i) the decay is exponential (equation (9.104)); ii) the measured absorption coefficient does not depend on the specific location of the sample on the wall; and iii) the absorption coefficient is constant between measurements in different reverberation chambers.

To complete the discussion on the appropriateness of the degree of diffusivity, one needs to study the role played by the diffusion in acoustic measurements of: i) the sound power levels of sources in reverberation chambers; ii) the transmission loss of walls; and iii) the absorption coefficients of materials.

### 9.4.5.3. Measurement of the sound power levels of sources in reverberation chambers

The power of a sound source generating a diffused-sound field in a chamber can be determined by measuring the spatial mean of the steady state pressure.

Equations (9.111), (9.112), (9.116) and (9.119)

$$W = \frac{p_{\text{rms}}^2}{\rho_0 c_0^2}, \quad I = \frac{c_0 W}{4}, \quad I = \frac{p_0}{a} \quad \text{and} \quad T = 0.16 \frac{V}{a},$$

lead directly to the expression of the sound power of the source as a function of the reverberation time of the chamber and the mean quadratic pressure,

$$p_0 = \frac{0.04}{\rho_0 c_0} \frac{V}{T} p_{\text{rms}}^2 = \frac{13.8}{\rho_0 c_0^2} \frac{V}{T} p_{\text{rms}}^2, \quad (9.138)$$

or, averaging over  $n$  measurement positions,

$$p_0 = \frac{13.8V}{\rho_0 c_0^2} \frac{1}{n} \sum_{i=1}^n \frac{\left( p_{\text{rms}_i}^2 \right)}{T_i}. \quad (9.139)$$

By the introduction of the decay rate  $D = 60/T$  (dB/s), equation (9.139) becomes

$$p_0 = \frac{V}{4.34 \rho_0 c_0^2} \frac{1}{n} \sum_{i=1}^n \left( p_{\text{rms}_i}^2 \right) D_i. \quad (9.140)$$

The evaluation of the spatial mean of the pressure must be restricted to the regions in the chamber where the sound field is diffused. Consequently, the microphone must be at least half a wavelength away from the walls and/or diffusers and positioned relatively far from the source to consider the direct sound field negligible compared to the reverberant field.

However, the mean quadratic pressure  $p_{\text{rms}}^2$  is, at average, greater at the vicinity of the walls, edges and corners than in the rest of the chamber. If the average is calculated over a set of points (index  $n$  in equation (9.140)), all more than half a wavelength away from the walls, equation (9.140) must be corrected. Ignoring first this effect for the edges and corners, but considering it for the walls (since they, unlike the edges and corners, represent most of the area of the chamber), the aforementioned correction can be introduced by multiplying the right-hand side term of equation (9.140) by  $[1 + S\lambda/(8V)]$  where  $\lambda$  denotes the wavelength and  $S$  the total area of the walls. This correction factor is obtained by calculating the ratio of the mean quadratic pressure at the vicinity of the walls, in random incidence, to the mean quadratic pressure away from the walls.

#### 9.4.5.4. Measurement of the transmission loss of partitions

Figure 9.6 shows the experimental setup for the measurement of the transmission loss of a partition.

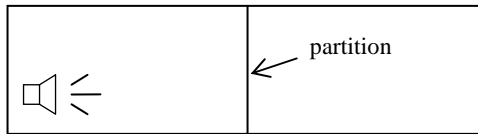

**Figure 9.6.** Setup for the measurement of the transmission loss of a partition

The partition separates two reverberation chambers. A loudspeaker in the source room generates a diffused sound field characterized by a mean quadratic pressure  $(p_{\text{rms}}^2)_1$ . In the receiving room (on the right-hand side of the wall in Figure 9.6), the transmitted sound generates a diffused sound field characterized by  $(p_{\text{rms}}^2)_2$ . If the sound field in the source room is diffused, the energy flow incident to the wall is described by equation (9.111) as

$$\phi_i = \frac{(p_{\text{rms}}^2)_1}{4\rho_0 c_0} S, \quad (9.141)$$

where  $S$  denotes the area of the wall.

To ensure perfect coupling between the sound field and the resonant flexural waves in the partition, the sound field in the room must be diffused so that there is always at least one acoustic mode of the room and one angle of incidence favorable to this coupling. This is necessary for the measured transmission loss to be constant from one laboratory to another.

The relationship with the transmitted sound power  $\phi_r$  (in the receiving room) is obtained by writing the energetic equilibrium in this room which principle requires that the power transmitted is always equal to the dissipated power (equation (9.113)),

$$\phi_r = S_2 \bar{\alpha}_2 \frac{(p_{\text{rms}})_2^2}{4\rho_0 c_0}, \quad (9.142)$$

where  $S_2 \bar{\alpha}_2$  denotes the total absorption in the receiving room, determined from the measurement of the decay curves ( $S_2 \bar{\alpha}_2 = 0.16 V_2 / T_2$ ).

The transmission loss, defined by

$$\text{TL} = 10 \log_{10} \left( \frac{\phi_i}{\phi_r} \right), \quad (9.143)$$

can then be written, according to equations (9.141) to (9.143), as

$$\text{TL} \approx \text{SPL}_1 - \text{SPL}_2 + 10 \log_{10} \left( \frac{S}{S_2 \bar{\alpha}_2} \right), \quad (9.144)$$

where  $\text{SPL}_1 - \text{SPL}_2 = 10 \log_{10} \left[ \frac{(p_{\text{rms}})_1^2}{(p_{\text{rms}})_2^2} \right]$  (SPL = sound pressure level).

The quantities  $\text{SPL}_1$ ,  $\text{SPL}_2$  and  $S_2 \bar{\alpha}_2$  are all functions of the frequency. Their respective values must therefore be evaluated at the same frequency when they are used in equation (9.144). Moreover, the total absorption in the receiving room ( $S_2 \bar{\alpha}_2$ ) must be measured while the partition is still there, particularly at low frequencies for lightweight partitions and for highly absorbent partitions (on the receiving side). Finally, the definition of the transmission loss (TL), as given by equation (9.144), makes sense only if the sound fields in both rooms are diffused.

The transmission loss of a partition measured in laboratories according to equation (9.144) in laboratories is used in architectural acoustics to predict the noise reduction between two adjacent rooms separated by the partition considered. The sound reduction is defined as

$$\text{SPL}_1 - \text{SPL}_2 = \text{TL} - 10 \log_{10} \left( \frac{S}{S_2 \bar{\alpha}_2} \right). \quad (9.145)$$

This equation shows that the relationships obtained depends on the transmission loss of the wall and the ratio  $\frac{S}{S_2 \bar{\alpha}_2}$  between the area considered and the total absorption in the receiving room.

Note: specialized laboratories are now moving toward intensimetry.

#### 9.4.5.5. *Measurement of Sabine's absorption coefficient*

The relationship between Sabine's absorption coefficient and the measured reverberation time has been given in section 9.4.2. This coefficient is highly sensitive to details of the considered setup and, in particular, to the degree of diffusivity of the sound field. To accurately measure Sabine's absorption coefficient, one needs to consider the dimensions of the sample, the conditions at the edges of the sample, the dimensions and shape of the room, the position of the sample in the room, the atmospheric conditions, the characteristics and positions of the diffusers, the averaging method used, etc.

The dispersion of the experimental results between various laboratories, or even between results obtained from the same laboratory with different diffuser positions, have generated much interest in the acoustic community and led to new techniques, among which is acoustic holography.

## 9.5. Brief history of room acoustics

Very early in history, a few curious people have investigated the phenomena of single or multiple reflections and reverberation. However, the classic concept of theater only appeared with the emergence of the Greeks and Latin civilizations: the amphitheatres then presented circular or elliptic geometries, and often had reflecting surfaces located behind the scenes, close to the actors. This configuration, by providing an optimal sound distribution and a "surround effect", allowed better distributions of the audience within the stands.

A millennium passed before the Italian Renaissance gave birth to fully-enclosed theaters. For the first time in the history of theaters, the sound was reflected several times in a closed space and spectators enjoyed a regular process of reverberation. Since then, concert halls have seen their acoustic criteria evolve significantly. The equilibrium between the direct sound from the stage and the accompanying music from the orchestra, the optimization of the reverberation according to the purpose of

the theater, and to the tonality and type of music, the spatial energy distribution, the diffusion, the feeling of multi-dimensions, and any psychological requirements (sensitive to the culture of each civilization at any given period of their history) are all familiar notions to concert-goers.

The first scientific analysis of sound fields in closed spaces had to wait until shortly before the 20<sup>th</sup> century. The first quarter of the 20<sup>th</sup> century saw the quantification of the notion of reverberation. Wallace Clément Sabine, while remaining sensitive to all known aspects of acoustic quality, concentrated his efforts on the notion of reverberation time, defined qualitatively as the period of time between the extinction of a sound source and the complete attenuation of the sound in the room. He related this notion to the geometry and nature of the walls. Up to 1925, the few simple statistical studies alongside the ray-tracing method and the limited knowledge on reverberation gave the impression that room acoustics was a rather uncomplicated science.

The second quarter of the 20<sup>th</sup> century led to the completely opposite conclusion, and highlighted the extreme complexity of the science. Published at the very beginning of World War II, the modal theory gave access to the physical characteristics of sound fields in steady state and in transient situation in media with simple geometries and weak absorption. It also provided the series of resonance frequencies unfavorable to uniform sound fields at a given frequency and location in the closed space. Even though modal theory has proven to be of no use in complex geometries or at the boundaries where acoustic properties are not simple, this wave-based theory led to the understanding of many phenomena. In the same time, it also increased the perplexity of acousticians facing the complexity of the acoustic properties of rooms.

The technological progress in the third quarter of the 20<sup>th</sup> century took the acousticians further, giving them access to experimental data and overcoming the difficulties encountered by the theoretical studies. Metrology appeared and became increasingly accurate allowing the study of sound fields in reduced-scale models and limiting the errors induced by too many assumptions. The arrival of computers opened the way to simulation techniques that were until then impossible and allowed the numerical treatment of numerous problems only solved by asymptotic methods before then. This major step led to the development of many new methods based on statistical descriptions and on the notions of sources and image sources.

Room acoustics is a combination of science, art, architecture and psychology that therefore constitutes a very vast area of study which can be divided into four domains: modal theory, statistical models, geometric models and psychoacoustics.

*This page intentionally left blank*

## Chapter 10

# Introduction to Non-linear Acoustics, Acoustics in Uniform Flow, and Aero-acoustics

Most of the discussion so far has been devoted to problems of linear acoustics in lightly dissipative fluids initially at rest, and introducing various phenomena and particularly the effects of the visco-thermal boundary layers. There was a short digression on the acoustic propagation in non-homogeneous fluids in motion in section 7.3 when discussing the geometric approximation method. However, the domain of application of the fundamental equations of acoustics presented in the first two chapters is much wider than previously seen in this book.

The object of this chapter is to exploit the potential of the fundamental equations of acoustics in order to treat some important aspects of science. Three areas of acoustics have been selected for that purpose: non-linear acoustics in fluids, acoustics in moving media, and aero-acoustics. This selection is by no means exhaustive. Moreover, these topics are barely discussed in this chapter and often the discussion simply tends to extend the domain of application of the fundamental equations of acoustics.

### **10.1. Introduction to non-linear acoustics in fluids initially at rest**

#### **10.1.1. *Introduction***

“Non-linear acoustics” is the branch of physics concerned with the phenomena related to acoustic and ultra-acoustic fields that cannot be described by the linear equations used so far (the principle of superposition is then not verified). The so-



called “non-linear phenomena” (harmonic distortion of a wave, for example) appear in the fundamental dynamic equations of continuous media, as well as in the equations of states for fluids.

The understanding of non-linear phenomena has not only deepened in acoustics, but also in areas related to optics, electromagnetism, physics of plasma, etc. Non-linear acoustics is not limited to the propagation of sound waves, but deals also with their interaction with other types of waves (optic, electromagnetic, etc.), with the propagation of sound waves in non-linear media generating secondary phenomena (such as cavitation, “acoustic” flows, chemical reactions, phase transitions, etc.), with the non-linear radiation of sound waves, etc. All these phenomena, along with those related to high amplitudes, make non-linear acoustics a very large area of study. Consequently, the present analysis is limited to the introduction of the fundamental wave equations with high amplitudes in homogeneous media initially at rest. However, these limited results are an excellent basis for the study of more complex problems.

Non-linear acoustics is among the “new” sciences; most of the developments and results have been carried out and obtained in the second half of the 20<sup>th</sup> century (Lighthill, Mendousse, Gol’dberg, Naugol’nykk, Beyer, Rudenko, Soluyan, Khokhlov, Blackstosk, Westervelt, Kuznetsov, etc.). Even though non-linear acoustics has only recently been recognized as an independent branch of physics, it is based on fundamental laws discovered at the end of the 19th century (Poisson, Stokes, Airy, Earnshaw, Riemann, etc.).

In non-linear acoustics, as in many domains of physics, various hypotheses must be made in order to solve the governing equations. There are three methods to achieve these simplified forms: i) using the perturbation methods to reduce the non-linear equation to a linear one where the non-linear terms appear in the non-homogeneous terms and are assumed known; ii) directly solving the non-linear equation to obtain an implicit solution from which, via hypotheses, the explicit solution can be derived; and iii) reducing the non-linear equation into another non-linear equation, the solution of which is known. These three methods are presented in section 10.1.2 for the first one, and in section 10.1.4 for the third one in visco-thermal fluids, and in section 10.1.3 for non-dissipative media.

A discussion on the orders of magnitude of the dissipative and non-linear terms is undertaken for the first study.

The three following studies are presented independently, but the discussion in each study is kept.

### 10.1.2. Equations of non-linear acoustics: linearization method

#### 10.1.2.1. The equations

In relation to lightly dissipative fluids and small amplitudes, the equations of non-linear acoustics can be dealt with by assuming that the non-linear acoustic field can only be derived by non-linear perturbation of the linear acoustics modes (called hyperbolic, potential or acoustic) of velocity  $\vec{v} = -\text{grad}\phi$  with  $\text{curl}\vec{v} = \vec{0}$  and by ignoring the two parabolic modes (the entropic and vortical ones) that do not propagate (at least outside the boundary layers). In other words, dissipations due to entropy and boundary layers are ignored here. Consequently, if the main variables considered are the density, particle velocity and entropy, the total acoustic field can be described by  $\rho'$ ,  $\vec{v}$ ,  $s$ ,  $\tau$  and  $p$  which denote the following acoustic variables

$$\begin{aligned}\rho &= \rho_0 + \rho', \\ \vec{v} &= \vec{v}, \\ S &= S_0 + s, \\ P &= P_0 + p, \\ T &= T_0 + \tau,\end{aligned}\tag{10.1}$$

where  $T_0$ ,  $P_0$ ,  $\rho_0$  and  $S_0$  are constants.

The present study is dedicated to the coupling of the linear acoustic mode with itself that occurs within the non-linear process being considered.

The substitution of equation (2.43) into equation (2.40), and consideration of equations (2.33) and (2.30), combined with equation (1.25), gives the three first equations of motion (10.2a) to (10.2c). Equations (10.2d) and (10.2e) are not explicitly given; they can, in particular, be in the forms of equations (2.4) and (2.5), and result in the following set of equations of motion

$$\frac{\partial \rho}{\partial t} + \text{div}(\rho \vec{v}) = 0, \tag{10.2a}$$

$$\rho \left[ \frac{\partial \vec{v}}{\partial t} + (\vec{v} \cdot \text{grad}) \vec{v} \right] = -\text{grad} P + \mu \Delta \vec{v} + \left( \eta + \frac{\mu}{3} \right) \text{grad} \text{div} \vec{v}, \tag{10.2b}$$

$$\rho T \left[ \frac{\partial S}{\partial t} + (\vec{v} \cdot \text{grad}) S \right] = \frac{\mu}{2} \left[ v_{i,j} + v_{j,i} - \frac{2}{3} v_{k,k} \right]^2 + \eta v_{k,k}^2 + \lambda \Delta T, \tag{10.2c}$$

$$P = P(\rho, S), \tag{10.2d}$$

$$T = T(\rho, S), \tag{10.2e}$$

where  $v_{i,j} = \frac{\partial v_i}{\partial x_j}$  and  $v_{k,k} = \frac{\partial v_k}{\partial x_k}$  are summed over all  $i, j$  and  $k$ .

Since

$$\text{c\ddot{u}rl } \vec{v} = \vec{0} = \text{c\ddot{u}rl } \text{c\ddot{u}rl } \vec{v} = \text{gr\ddot{a}d } \text{div } \vec{v} - \Delta \vec{v}, \tag{10.3a}$$

and

$$\vec{v} \cdot \text{gr\ddot{a}d } \vec{v} = \frac{1}{2} \text{gr\ddot{a}d } |\vec{v}|^2 + (\text{c\ddot{u}rl } \vec{v}) \wedge \vec{v}, \tag{10.3b}$$

the substitution of equations (10.1) into equations (10.2) leads to the system of equations for the acoustic perturbation

$$\frac{\partial}{\partial t} \rho' + \text{div} (\rho_0 \vec{v} + \rho' \vec{v}) = 0, \tag{10.4a}$$

$$(\rho_0 + \rho') \left( \frac{\partial \vec{v}}{\partial t} + \frac{1}{2} \text{gr\ddot{a}d } v^2 \right) = -\text{gr\ddot{a}d } p + \left( \eta + \frac{4}{3} \mu \right) \Delta \vec{v}, \tag{10.4b}$$

$$\begin{aligned} (\rho_0 + \rho') (T_0 + \tau) \left[ \frac{\partial s}{\partial t} + (\vec{v} \cdot \text{gr\ddot{a}d } s) \right] \\ = \frac{\mu}{2} \left( v_{i,j} + v_{j,i} - \frac{2}{3} v_{k,k} \right)^2 + \eta (\text{div } \vec{v})^2 + \lambda \Delta \tau, \end{aligned} \tag{10.4c}$$

$$\text{c\ddot{u}rl } \vec{v} = \vec{0}, \tag{10.4d}$$

$$P = P(\rho, S), P_0 + p = P(\rho_0 + \rho', S_0 + s), \tag{10.4e}$$

$$T = T(\rho, S), T_0 + \tau = T(\rho_0 + \rho', S_0 + s). \tag{10.4f}$$

Since the perturbation is assumed to be small, the pressure (equation (10.4e)) and temperature (equation (10.4f)) can be expanded as Taylor series limited to the first orders and taken at their respective values at rest

$$p = \left. \frac{\partial P}{\partial \rho} \right|_S \rho' + \left. \frac{\partial P}{\partial S} \right|_\rho s + \frac{1}{2} \left. \frac{\partial^2 P}{\partial \rho^2} \right|_{SS} \rho'^2 + \left. \frac{\partial^2 P}{\partial \rho \partial S} \right|_{S\rho} \rho' s + \frac{1}{2} \left. \frac{\partial^2 P}{\partial S^2} \right|_{\rho\rho} s^2 + \dots, \tag{10.5}$$

$$\tau = \left. \frac{\partial T}{\partial \rho} \right|_S \rho' + \left. \frac{\partial T}{\partial S} \right|_\rho s + \dots, \tag{10.6}$$

the derivatives being calculated at  $(\rho_0, S_0)$ .

A simple derivation of equation (1.51) gives the expressions of the expansion coefficients for a perfect gas as

$$\left. \frac{\partial P}{\partial \rho} \right)_s = c_0^2, \quad \left. \frac{1}{2} \frac{\partial^2 P}{\partial \rho^2} \right)_{SS} = \frac{\gamma-1}{2\rho_0} c_0^2 \quad \text{and} \quad \left. \frac{\partial P}{\partial S} \right)_\rho = c_0^2 \frac{\rho_0}{\gamma C_v}, \quad (10.7)$$

where  $c_0^2 = \gamma \frac{P_0}{\rho_0}$ .

The system of partial differential equations, verified by the acoustic perturbation of small amplitude, written at the second order using the principal variables  $\rho'$ ,  $\vec{v}$  and  $s$ , is

$$\frac{\partial}{\partial t} \rho' + \text{div}(\rho_0 \vec{v} + \rho' \vec{v}) = 0, \quad (10.8a)$$

$$\begin{aligned} (\rho_0 + \rho') \left( \frac{\partial}{\partial t} \vec{v} + \frac{1}{2} \text{grad } v^2 \right) = & -c_0^2 \text{grad } \rho' - \left. \frac{\partial P}{\partial S} \right)_\rho \text{grad } s \\ & - \left. \frac{1}{2} \frac{\partial^2 P}{\partial \rho^2} \right)_{SS} \text{grad}(\rho'^2) - \left. \frac{\partial^2 P}{\partial \rho \partial S} \right)_{S\rho} \text{grad}(\rho' s) \\ & - \left. \frac{1}{2} \frac{\partial^2 P}{\partial S^2} \right)_{\rho\rho} \text{grad}(s^2) + \left( \eta + \frac{4}{3} \mu \right) \Delta \vec{v}, \end{aligned} \quad (10.8b)$$

$$\begin{aligned} (\rho_0 + \rho') \left[ T_0 + \left. \frac{\partial T}{\partial \rho} \right)_s \rho' + \left. \frac{\partial T}{\partial S} \right)_\rho s \right] \left[ \frac{\partial s}{\partial t} + (\vec{v} \cdot \text{grad}) s \right] = \\ \frac{\mu}{2} \left( v_{i,j} + v_{j,i} - \frac{2}{3} v_{k,k} \right)^2 + \eta (\text{div } \vec{v})^2 + \lambda \left. \frac{\partial T}{\partial \rho} \right)_s \Delta \rho' + \lambda \left. \frac{\partial T}{\partial S} \right)_\rho \Delta s. \end{aligned} \quad (10.8c)$$

Note 1: the expansion expressed in (10.5) is often written in the form

$$p = A \frac{\rho'}{\rho_0} + \frac{B}{2} \left( \frac{\rho'}{\rho_0} \right)^2 + \dots \quad (10.9a)$$

where the factor

$$\frac{B}{2A} = \left. \frac{\rho_0}{2c_0^2} \frac{\partial^2 P}{\partial \rho^2} \right)_{SS} \quad (10.9b)$$

is called the non-linearity parameter of the medium. It is equal to  $(\gamma - 1)/2$  for a perfect gas at constant specific heat (equation (10.7)).

Note 2: for the sake of simplicity, the dissipative term associated with the thermal conductivity

$$-\left. \frac{\partial P}{\partial S} \right)_\rho \text{ grad } s$$

in equation (10.8b) is expressed from now at the lowest order. This is justified, *a posteriori*, in the following section.

The substitution of Euler's linear equation ( $\text{grad } p = -\rho_0 \partial \vec{v} / \partial t$ ) into the adiabatic temperature variation (equation (2.82a)),  $\tau = (\gamma - 1)p / (\gamma \hat{\beta})$ , leads to the equation of conservation of the entropy

$$\rho_0 T_0 \frac{\partial s}{\partial t} = \lambda \frac{\gamma - 1}{\gamma \hat{\beta}} \text{div} \left( -\rho \frac{\partial \vec{v}}{\partial t} \right),$$

or, noting that for a perfect gas  $\hat{\beta} = P_0 / T_0$ , to

$$s = -\frac{(\gamma - 1) \lambda}{\gamma P_0} \text{div } \vec{v}. \tag{10.10}$$

Consequently, according to the third relationship of equation (10.7), one obtains

$$-\left. \frac{\partial P}{\partial S} \right)_\rho s = \gamma \frac{P_0}{\rho_0} \frac{\rho_0 (\gamma - 1) \lambda}{P_0 \gamma^2 C_v} \text{div } \vec{v} = \frac{(\gamma - 1) \lambda}{C_p} \text{div } \vec{v},$$

and finally

$$-\left. \frac{\partial P}{\partial S} \right)_\rho \text{ grad } s = \frac{(\gamma - 1) \lambda}{C_p} \Delta \vec{v}. \tag{10.11}$$

10.1.2.2. Orders of magnitude of each term of equations (10.8)

In order to rid the equations (10.8) of the negligible factors and at the same time simplify these equations for the specific problems at hand, a comparison of the orders of magnitude of each term in equation (10.8) is carried out. The acoustic

perturbation is locally assumed close to a sinusoidal plane wave that is a solution to the equations of linear acoustics in an ideal fluid. It is therefore written as

$$v = V_0 \cos(\omega t - kz), \quad (10.12a)$$

$$\rho' = \frac{\rho_0}{c_0} v = \frac{\rho_0 V_0}{c_0} \cos(\omega t - kz), \quad (10.12b)$$

$$s \approx 0. \quad (10.12c)$$

The quantities  $(\rho'/\rho_0)$  and  $(v/c_0)$  are then of the same order of magnitude as the acoustic Mach number  $M_a = V_0/c_0$ ,

$$\frac{\rho'}{\rho_0} \sim \frac{v}{c_0} \sim M_a. \quad (10.13)$$

The acoustic Mach number then gives the order of magnitude of the perturbation. The parameter used to represent the order of magnitude of the dissipative effect is the reciprocal  $R_e^{-1}$  of the Reynolds number

$$R_e = \frac{2\pi}{\omega} \frac{\rho_0 c_0^2}{\mu}, \quad (10.14)$$

and comparison between the effects of viscosity and thermal conduction effect is represented by Prandtl's number

$$P_r = \frac{\mu C_p}{\lambda}. \quad (10.15)$$

For lightly non-linear motions with little dissipation,

$$M_a \ll 1 \text{ and } R_e^{-1} \ll 1, \quad (10.16)$$

and, since the factor  $\lambda/C_p$  related to the coefficient of thermal conduction  $\lambda$  is assumed of the same order of magnitude as the coefficient of viscosity  $\mu$ , the Prandtl number is finite, thus

$$\frac{\lambda}{C_p} = \frac{2\pi\rho_0 c_0^2}{\omega} \frac{1}{P_r R_e} \sim R_e^{-1}. \quad (10.17)$$

When focusing on the orders of magnitude of the terms in equations (10.8b), it is convenient to choose a quantity of reference, the order of magnitude of which is the same as the order of the first linear term  $\rho_0 \partial \bar{v} / \partial t$ , equal to  $\rho_0 V_0 f$  (give or take  $2\pi$ ) where  $f$  is the frequency.

By ignoring the second order of the entropy  $s$  (quasi-adiabatic motion), the non-linear terms are

$$\rho' \frac{\partial}{\partial t} \bar{v} + \frac{\rho_0}{2} \text{grad } v^2 \quad (\text{non-linearity of the motion}), \tag{10.18a}$$

$$\left. \frac{1}{2} \frac{\partial^2 P}{\partial \rho^2} \right)_{SS} \text{grad } \rho^2 \quad (\text{non-linearity of the medium}), \tag{10.18b}$$

which orders of magnitudes are respectively

$$\rho_0 \frac{V_0}{c_0} \omega V_0 + 2 \frac{\rho_0}{2} \frac{\omega}{c_0} V_0^2 \tag{10.19}$$

and

$$2 \left. \frac{1}{2} \frac{\partial^2 P}{\partial \rho^2} \right)_{SS} \frac{\omega}{c_0} \frac{\rho_0^2 V_0^2}{c_0^2}, \tag{10.20}$$

and the sum of which is equal to

$$\rho_0 V_0 f \quad 4\pi M_a \beta, \tag{10.21}$$

$$\text{where } \beta = 1 + \frac{B}{2A}, \tag{10.22}$$

$\beta$  being the parameter of total non-linearity and the sum of the non-linearity of amplitude and of the medium (10.9).

The order of magnitude of the terms associated with the viscosity and thermal conduction are respectively

$$\left( \frac{4}{3} \mu + \eta \right) |\Delta \bar{v}| \sim \rho_0 V_0 f \frac{4\pi^2}{Re} \left( \frac{4}{3} + \frac{\eta}{\mu} \right),$$

and (equation (10.11))

$$-\left.\frac{\partial P}{\partial S}\right)_p \text{grad } s = \frac{(\gamma-1)\lambda}{C_p} |\Delta \vec{v}| \sim \rho_0 V_0 f \frac{4\pi^2(\gamma-1)}{R_e P_r}.$$

The order of magnitude of the total dissipation effects is given by

$$\rho_0 V_0 f \frac{4\pi^2}{R_e} \left[ \frac{4}{3} + \frac{\eta}{\mu} + \frac{\gamma-1}{P_r} \right]. \quad (10.23)$$

The ratio of the order of magnitude of the “non-linear terms” to the “dissipative terms” defines Gol’dberg’s number, or the acoustic Reynolds number, as

$$G = \frac{M_a R_e \beta}{\pi \left[ \frac{4}{3} + \frac{\eta}{\mu} + \frac{\gamma-1}{P_r} \right]} = \frac{M_a R_e \beta v_0}{\pi \nu}, \quad (10.24)$$

with

$$\beta = 1 + \frac{B}{2A} = 1 + \frac{\rho_0}{2c_0^2} \left. \frac{\partial^2 P}{\partial \rho^2} \right)_{SS}, \quad v = \frac{1}{\rho_0} \left[ \frac{4}{3} \mu + \eta + \frac{(\gamma-1)\lambda}{C_p} \right],$$

$v_0 = \mu / \rho_0$  (coefficient of dynamic viscosity).

In the above result,  $M_a$ ,  $\beta M_a$  and  $R_e^{-1}$  are the indicators of, respectively, the non-linearity of the amplitude, the total non-linearity (amplitude and medium), and the dissipative effects. For a perfect gas of constant specific heat,  $\beta = (\gamma + 1) / 2$ .

Note: the non-linear and dissipative terms are of the same order of magnitude if  $G \approx 1$ , thus if

$$M_a R_e \beta \approx \pi \left( \frac{4}{3} + \frac{\eta}{\mu} + \frac{\gamma-1}{P_r} \right). \quad (10.25)$$

Note: for the air,  $\beta \approx 1.2$  and  $\frac{4}{3} + \frac{\eta}{\mu} \sim \frac{(\gamma-1)\lambda}{\mu C_p} = \frac{\gamma-1}{P_r}$ .



In this context, equation (10.25) becomes

$$M_a R_e \approx 2\pi \left( \frac{4}{3} + \frac{\eta}{\mu} \right), \quad (10.26)$$

$$\text{or } \frac{V_0}{\omega} \approx \frac{1}{\rho_0 c_0} \left( \frac{4}{3} \mu + \eta \right). \quad (10.27)$$

The first term of equation (10.27) represents the particle displacement, while the second represents the mean free path of the molecules in the medium. The effects of non-linearity and dissipation present the same order of magnitude when the particle displacement is of the same order of magnitude as the mean free path. In practice, this corresponds to 90 dB in the air at frequencies around 1 kHz.

For pure water at 400 kHz,

$G \sim 0.05$  at 60 dB (re 10-1 Pa),

$G \sim 0.05$  at 140 dB.

### 10.1.2.3. *The solutions*

The solutions of problem (10.8) are assumed to be in the simple asymptotic form

$$\rho' = \rho_1 + \rho_2 + \dots, \quad (10.28a)$$

$$\bar{v} = \bar{v}_1 + \bar{v}_2 + \dots, \quad (10.28b)$$

$$s = s_1 + s_2 + \dots, \quad (10.28c)$$

where the quantities, the indexes of which are greater than one, are considered to be perturbations of the linear acoustic quantities, the order of magnitude which decreases as the indexes increase. Three different cases are considered depending on the value of the Gol'dberg's number that governs the order of magnitude of the non-linear terms with respect to the dissipation terms and satisfies

$$G \ll 1, G \sim 1 \text{ or } G \gg 1. \quad (10.29)$$

#### 10.1.2.3.1. Equations and associated solutions in highly dissipative media ( $G \ll 1$ )

In a highly dissipative medium, the dissipative effects are assumed greater than the non-linearity effects, but remain small. This is the case when the following conditions are fulfilled: small amplitude of the perturbation, lightly non-linear medium ( $\beta \sim 1$ ), high frequencies (high visco-thermal absorption depending on  $\omega^2$ ), large-values dissipation coefficients.

These hypotheses can be expressed as

$$0 < M_a R_e^{-1} \ll M_a \beta \ll R_e^{-1} \ll 1. \quad (10.30)$$

The substitution of equations (10.28) into equations (10.8), given relationship (10.11), leads, at the first order, to

$$\frac{\partial \rho_1}{\partial t} + \rho_0 \operatorname{div} \bar{v}_1 = 0, \quad (10.31a)$$

$$\rho_0 \frac{\partial \bar{v}_1}{\partial t} + c_0^2 \operatorname{grad} \rho_1 - \frac{(\gamma-1)\lambda}{C_p} \Delta \bar{v}_1 - \mu \left( \frac{4}{3} + \frac{\eta}{\mu} \right) \Delta \bar{v}_1 = \bar{0}, \quad (10.31b)$$

$$\rho_0 T_0 \frac{\partial s_1}{\partial t} - \lambda \left[ \frac{\partial T}{\partial \rho} \right]_S \Delta \rho_1 + \left[ \frac{\partial T}{\partial S} \right]_\rho \Delta s_1 = 0, \quad (10.31c)$$

and at the second order to

$$\frac{\partial \rho_2}{\partial t} + \rho_0 \operatorname{div} \bar{v}_2 = -\operatorname{div} (\rho_1 \bar{v}_1), \quad (10.32a)$$

$$\begin{aligned} \rho_0 \frac{\partial \bar{v}_2}{\partial t} + c_0^2 \operatorname{grad} \rho_2 + \frac{\partial P}{\partial S} \operatorname{grad} s_2 - \mu \left( \frac{4}{3} + \frac{\eta}{\mu} \right) \Delta \bar{v}_2 = \\ - \rho_1 \frac{\partial \bar{v}_1}{\partial t} - \rho_0 (\bar{v}_1 \cdot \operatorname{grad}) \bar{v}_1 - \frac{1}{2} \frac{\partial^2 P}{\partial \rho^2} \operatorname{grad} \rho_1^2 \\ - \frac{\partial^2 P}{\partial \rho \partial S} \operatorname{grad} (\rho_1 s_1) - \frac{1}{2} \frac{\partial^2 P}{\partial S^2} \operatorname{grad} s_1^2, \end{aligned} \quad (10.32b)$$

$$\begin{aligned} \rho_0 T_0 \frac{\partial s_2}{\partial t} - \lambda \left[ \frac{\partial T}{\partial \rho} \right]_S \Delta \rho_2 + \left[ \frac{\partial T}{\partial S} \right]_\rho \Delta s_2 = -\rho_0 T_0 (\bar{v}_1 \cdot \operatorname{grad}) s_1 \\ - \left[ \rho_0 \frac{\partial T}{\partial \rho} \right]_S + T_0 \left[ \rho_1 \frac{\partial s_1}{\partial t} - \rho_0 \frac{\partial T}{\partial S} \right]_\rho s_1 \frac{\partial s_1}{\partial t} \\ + \mu \left[ v_{li,j} + v_{lj,i} - \frac{2}{3} v_{lk,k} \right]^2 + \eta (\operatorname{div} \bar{v}_1)^2. \end{aligned} \quad (10.32c)$$

Equations (10.31) are the equations of propagation in dissipative media in linear acoustics. They are written here in a different form than the one presented in the

third chapter, but lead to the same equation of propagation of the acoustic motion (equation (2.76))

$$\left[ \left( 1 + \ell_{\text{vh}} \frac{1}{c_0} \frac{\partial}{\partial t} \right) \Delta - \frac{1}{c_0^2} \frac{\partial^2}{\partial t^2} \right] \vec{v}_1 = \vec{0}, \quad (10.33)$$

$$\text{with } \Delta \vec{v}_1 = \text{grad div } \vec{v}_1 - \text{curl curl } \vec{v}_1 = \text{grad div } \vec{v}_1.$$

When one considers the problem in one dimension, with a sinusoidal source at  $z = 0$ , equation (10.33) becomes

$$\left[ \left( 1 + \ell_{\text{vh}} \frac{1}{c_0} \frac{\partial}{\partial t} \right) \frac{\partial^2}{\partial z^2} - \frac{1}{c_0^2} \frac{\partial^2}{\partial t^2} \right] v_1(z, t) = 0, \quad \forall z, \forall t, \quad (10.34a)$$

$$v_1(z = 0, t) = V_0 \sin(\omega t). \quad (10.34b)$$

The solution written in the form of a damped harmonic plane wave propagating in the positive  $z$ -direction is

$$v_1 = V_0 e^{-\Gamma z} \sin(\omega t - k_0 z), \quad (10.35)$$

where, according to equations (2.86) and (4.10),

$$\Gamma = \frac{1}{2} k_0^2 \ell_{\text{vh}} = \frac{k_0^2}{2\rho_0 c_0} \left( \frac{4}{3} \mu + \eta + \frac{\gamma - 1}{C_p} \lambda \right), \quad (10.36)$$

and, according to equation (10.31a),

$$\rho_1 = \frac{\rho_0}{c_0} v_1 = \frac{\rho_0 V_0}{c_0} e^{-\Gamma z} \sin(\omega t - k_0 z). \quad (10.37)$$

The derivation of the equation of propagation governing the acoustic field expanded to the second order is limited here to the frequent situation where the Gol'dberg number is smaller than 1 ( $G \ll 1$ ), but remains such that the terms of first order containing the entropy in equations (10.32b and c) and those containing the viscosity in equations (10.32c) are negligible.

Equation (10.32c) can then be written in the same form as equation (10.31c). The derivation method used in the note in section 10.1.2.1 leads (equation (10.11)) to

$$-\left. \frac{\partial P}{\partial S} \right)_\rho \text{grad } s_2 \approx \frac{(\gamma - 1) \lambda}{C_p} \Delta \bar{v}_2. \quad (10.38)$$

When one considers the aforementioned limitations, the following equation of propagation for the perturbation term  $\bar{v}_2$  of the acoustic particle velocity ( $\bar{v} = \bar{v}_1 + \bar{v}_2$ ) can be written as

$$\begin{aligned} \triangleq \bar{v}_2 + \frac{v}{c_0^2} \frac{\partial}{\partial t} \Delta \bar{v}_2 = & -\frac{1}{\rho_0} \text{grad div}(\rho_1 \bar{v}_1) + \frac{1}{\rho_0 c_0^2} \frac{\partial}{\partial t} \left( \rho_1 \frac{\partial}{\partial t} \bar{v}_1 \right) \\ & + \frac{1}{c_0^2} \frac{\partial}{\partial t} (\bar{v}_1 \cdot \text{grad}) \bar{v}_1 + \frac{1}{2\rho_0 c_0^2} \frac{\partial^2 P}{\partial \rho^2} \bigg)_{SS} \frac{\partial}{\partial t} \text{grad } \rho_1^2. \end{aligned} \quad (10.39)$$

For one-dimensional problems, ignoring in the differentiation the terms of superior order leads to

$$\begin{aligned} \frac{\partial v_1}{\partial z} & \approx -k_0 V_0 e^{-\Gamma z} \cos(\omega t - k_0 z), \\ \frac{\partial v_1}{\partial t} & \approx \omega V_0 e^{-\Gamma z} \cos(\omega t - k_0 z), \end{aligned}$$

and finally equation (10.39) is written in the form

$$\triangleq_z v_2 + \frac{v}{c_0^2} \frac{\partial}{\partial t} \frac{\partial^2}{\partial z^2} v_2 = -\omega k_0 \frac{V_0^2}{c_0^2} 2\beta e^{-2\Gamma z} \cos[2(\omega t - k_0 z)] \quad (10.40)$$

where  $\beta$  is the parameter of non-linearity defined in equation (10.22).

The solution that vanishes at  $z = 0$  can then be written as

$$v_2(z, t) = \frac{\beta}{2vk_0} V_0^2 \left[ e^{-2\Gamma z} - e^{-4\Gamma z} \right] \sin[2(\omega t - k_0 z)]. \quad (10.41)$$

Finally,

$$v = V_0 e^{-\Gamma z} \sin(\omega t - k_0 z) + \frac{\beta}{2vk_0} V_0^2 \left[ e^{-2\Gamma z} - e^{-4\Gamma z} \right] \sin[2(\omega t - k_0 z)]. \quad (10.42)$$

Figure 10.1 gives the graphic representation of the solutions (10.35) and (10.41) for the fundamental  $v_1$  and for the first harmonic  $v_2$  affected by non-linearity ( $v_2$  vanishes with  $\beta$ ). The scales for  $v_1$  and  $v_2$  are different and the profile of the modulating signals is exaggerated.

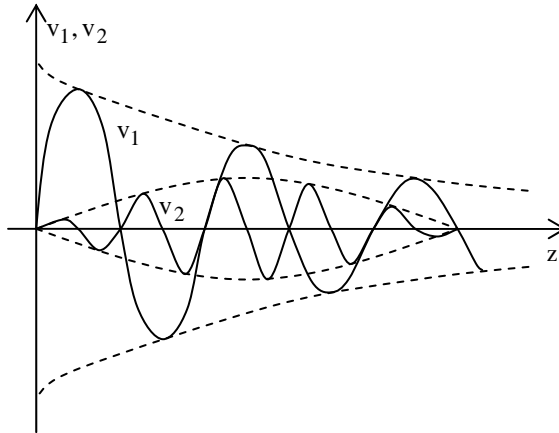

**Figure 10.1.** Solution for the fundamental  $v_1$  and the first harmonic  $v_2$  of the problem (10.31) – (10.32) in one dimension

10.1.2.3.2. Solutions when the non-linear effects and dissipative effects are of the same order of magnitude ( $G \sim 1$ )

When the non-linear effects are of the same order of magnitude as the dissipative effects, Gol'dberg's number is close to one, and

$$0 < \beta M_a \approx R_e^{-1} \ll 1.$$

The equations and their solutions can then be written without difficulty (and without resorting to more assumptions) by adopting the same approach as in section 10.1.2.3.1. The governing equations (10.8) are, at the first order,

$$\frac{\partial \rho_1}{\partial t} + \rho_0 \operatorname{div} \bar{v}_1 = 0, \tag{10.43a}$$

$$\rho_0 \frac{\partial \bar{v}_1}{\partial t} + c_0^2 \operatorname{grad} \rho_1 = \bar{0}, \tag{10.43b}$$

$$\frac{\partial s_1}{\partial t} = 0; \quad (10.43c)$$

and at the second,

$$\frac{\partial \rho_2}{\partial t} + \rho_0 \operatorname{div} \bar{v}_2 = -\operatorname{div}(\rho_1 \bar{v}_1), \quad (10.44a)$$

$$\rho_0 \left. \frac{\partial \bar{v}_2}{\partial t} + c_0^2 \operatorname{grad} \rho_2 + \frac{\partial \mathbf{P}}{\partial \mathbf{S}} \right)_\rho \operatorname{grad} s_2 =$$

$$-\rho_1 \left. \frac{\partial \bar{v}_1}{\partial t} - \frac{1}{2} \rho_0 \operatorname{grad} \bar{v}_1^2 - \frac{1}{2} \frac{\partial^2 \mathbf{P}}{\partial \rho^2} \right)_{\text{SS}} \operatorname{grad} \rho_1^2 + \mu \left( \frac{4}{3} + \frac{\eta}{\mu} \right) \Delta \bar{v}_1, \quad (10.44b)$$

$$\rho_0 T_0 \left. \frac{\partial s_2}{\partial t} = \lambda \frac{\partial \mathbf{T}}{\partial \rho} \right)_S \Delta \rho_1. \quad (10.44c)$$

The resulting equations of propagation are, respectively,

$$\triangleq \bar{v}_1 = \bar{0}, \quad (10.45a)$$

$$\triangleq \bar{v}_2 = -\frac{1}{\rho_0} \operatorname{grad} \operatorname{div}(\rho_1 \bar{v}_1) + \frac{1}{\rho_0 c_0^2} \frac{\partial}{\partial t} \left( \rho_1 \frac{\partial}{\partial t} \bar{v}_1 \right) + \frac{1}{2c_0^2} \frac{\partial}{\partial t} \operatorname{grad} v_1^2$$

$$+ \frac{1}{2\rho_0 c_0^2} \frac{\partial^2 \mathbf{P}}{\partial \rho^2} \right)_{\text{SS}} \frac{\partial}{\partial t} \operatorname{grad} \rho_1^2 - \frac{\nu}{c_0^2} \frac{\partial}{\partial t} \Delta \bar{v}_1. \quad (10.45b)$$

In one dimension, the solutions can be written ( $s_1 = 0$ ) as

$$v_1 = V_0 \sin(\omega t - k_0 z) = \frac{c_0}{\rho_0} \rho_1. \quad (10.46a)$$

By substituting equation (10.45a) into (10.45b), one obtains

$$\triangleq_z v_2 = -\omega k_0 \frac{V_0^2}{c_0^2} 2\beta \cos[2(\omega t - k_0 z)] + \frac{k_0^2 \omega \nu}{c_0} \frac{V_0^2}{c_0^2} \cos(\omega t - k_0 z), \quad (10.46b)$$

leading to the following solution

$$v_2 = V_0^2 (\omega t + k_0 z) \left[ \frac{\beta}{4c_0} \sin [2(\omega t - k_0 z)] - \frac{k_0 v}{4c_0^2} \sin (\omega t - k_0 z) \right].$$

Since the solution must be equal to zero at  $z = 0$ ,  $v_2$  must be given by

$$v_2(z, t) = \frac{V_0^2}{2c_0} k_0 z \left[ \beta \sin [2(\omega t - k_0 z)] - \frac{k_0 v}{c_0} \sin (\omega t - k_0 z) \right]. \tag{10.47}$$

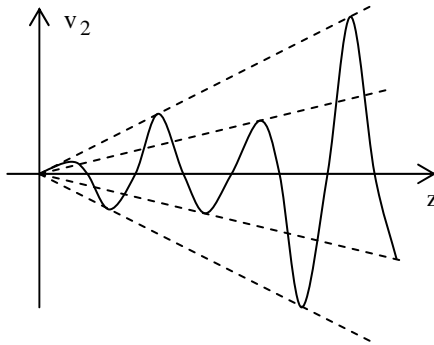

**Figure 10.2.** Evolution of the first harmonic from  $z = 0$

The amplitude of the first harmonic  $v_2$  increases with  $z$  (Figure 10.2) up to a certain distance imposed by the process presented in section 10.1.2.3.1 since the dissipative factor becomes predominant as Gol'dberg's number decreases during propagation.

10.1.2.3.3. Equations and solutions for highly non-linear motion ( $G \gg 1$ )

The motion is highly non-linear when one of the following conditions is satisfied: high amplitude; significantly non-linear medium ( $\beta \gg 1$ ); low frequencies; or small dissipation coefficients. In these conditions, Gol'dberg's number is greater than one and

$$0 < R_e^{-1} \ll \beta M_a \ll 1. \tag{10.48}$$

The equations and solutions can be deduced from those obtained for  $G \sim 1$  (section 10.1.2.3.2) by writing that  $\mu$ ,  $\eta$  and  $\lambda$  are null and consequently that  $v$  is

null (quantities defined by equation (10.24)). The corresponding first harmonic is written in the form

$$v_2 = \frac{V_0^2 k_0 \beta}{2c_0} z \sin [2(\omega t - k_0 z)]. \quad (10.49)$$

This solution increases with  $z$  (Figure 10.3) and consequently leads to the same conclusions and remarks as those in section 10.1.2.3.2.

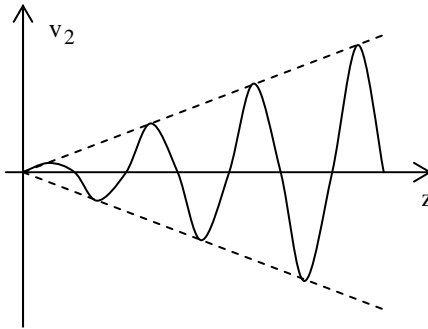

**Figure 10.3.** Evolution of the amplitude of the first harmonic from  $z = 0$  (hypotheses in section 10.2.3.2)

Note 1: in highly non-linear fluids ( $G \gg 1$ ), for which  $\left. \frac{\partial^2 P}{\partial \rho^2} \right|_{SS} \gg 1$  (or  $\beta \gg 1$ ), the only non-linearity effects to be considered are those contained in the equation of state written as

$$p = \rho' c^2(\rho'), \quad (10.50a)$$

with, in first approximation (according to equations (10.5) and (10.7)),

$$c^2(\rho') = c_0^2 \left[ 1 + \frac{(\gamma - 1)}{2} \frac{\rho'}{\rho_0} \right], \quad (10.50b)$$

where

$$dP = dp = c^2(\rho') d\rho', \quad (10.51a)$$



with, according to equation (1.51) and at the first order of  $\rho'/c_0$ ,

$$c^2 \approx c_0^2 \left[ 1 + (\gamma - 1) \frac{\rho'}{\rho_0} \right], \text{ where } c^2 = \gamma P / \rho \text{ (equation (1.49) with } dS=0\text{)}. \quad (10.51b)$$

The substitution of equation (10.50a) into the equations

$$\frac{\partial \rho'}{\partial t} + \rho_0 \operatorname{div} \vec{v} = 0 \text{ and } \rho_0 \frac{\partial \vec{v}}{\partial t} + \operatorname{grad} p = 0,$$

gives the non-linear equation of propagation for  $\rho'$

$$\Delta \left[ \rho' c^2(\rho') \right] - \frac{\partial^2 \rho'}{\partial t^2} = 0. \quad (10.52)$$

Note 2: the antagonism between the non-linear effects and the dissipative effects is mentioned twice in the previous sections (sections 10.2.3.2 and 10.2.3.3), in particular when it comes to justifying an exponential decrease of the amplitude of the first harmonic. The following discussion is devoted to this phenomenon.

Starting from a solution where  $G \gg 1$  at the vicinity of the source, in the case of a sinusoidal plane wave for example, three regions along the direction of radiation must be identified.

Close to the source, the amplitude of the wave is large and consequently the non-linear effects are predominant, favoring the occurrence of intensifying harmonics (case where  $G \gg 1$ ; see Figure 10.4a).

Further on, the wave presents harmonics, the amplitudes of which are great enough to maximize the distortion of the profile (triangle like profile; see Figure 10.4b). However, the increase of the harmonics amplitude is compensated for by the dissipation in the medium, the significance of which increases with the square of the frequency, imposing a “quasi-stable” profile to the wave (case where  $G \sim 1$ ).

Finally, the wave tends to retrieve its original sinusoidal shape while still being attenuated. The phenomena of dissipation become more and more predominant as the frequency increases (for example, where  $G \ll 1$ ; see Figure 10.4c). If  $G \ll 1$  from the first region (near field), the last case is the only one to consider during the propagation.

It is instructive to note that the attenuation related to the molecular relaxation, predominant at the so-called relaxation frequencies, does not significantly affect the above description.

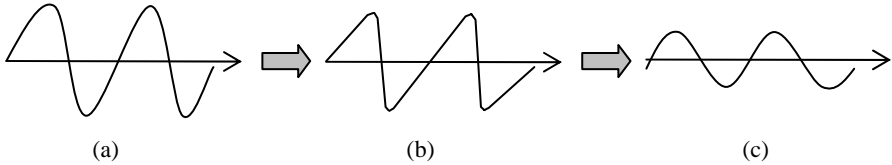

**Figure 10.4.** Profile of the sound wave (a) in the near field  $G \gg 1$ , (b) in the intermediate region  $G \sim 1$  and (c) in the far field  $G \ll 1$

The first consequence of the non-linear effects is therefore an additional attenuation due to the energy transfer from the initial wave to its harmonic component which is more attenuated than the initial wave.

Note 3: the derivation of the equations of motion for the pressure perturbation  $p_2$  in a non-dissipative fluid in adiabatic motion (following the same approach as above) leads, at the second order, to the equation of propagation

$$\hat{\triangle} p_2 = -\frac{\beta}{\rho_0 c_0^4} \frac{\partial^2}{\partial t^2} (p_1^2). \tag{10.53}$$

This is Lighthill’s equation based on the assumption that  $\hat{\triangle} \bar{v}_1^2 = \hat{\triangle} \rho_1^2 = 0$ .

**10.1.3. Equations of propagation in non-dissipative fluids in one dimension, Fubini’s solution of the implicit equations**

10.1.3.1. *Implicit equations in Eulerian coordinates*

For a non-dissipative fluid in one direction (x-direction for example), the general equations (1.28), (1.32) and (1.36) can be written in the form

$$\rho_{,t} + v \rho_{,x} + \rho v_{,x} = 0, \tag{10.54a}$$

$$v_{,t} + v v_{,x} + \rho^{-1} p_{,x} = 0, \tag{10.54b}$$

$$p_{,x} = c^2 \rho_{,x}, \tag{10.54c}$$

where  $f_{,u}$  denotes  $\partial f / \partial u$  and where the parameter  $c$  is given by equation (10.51b) as

$$c = c_0 \left( 1 + \frac{\gamma - 1}{2} \frac{\rho'}{\rho_0} \right) \approx c_0 \left( 1 \pm \frac{\gamma - 1}{2} \frac{v}{c_0} \right). \quad (10.55)$$

(the derivation of the second equality is given in the following section).

By introducing the concept of “simple wave”, for which all parameters describing the process can be expressed as functions of a single parameter  $\phi$  depending on the spatial and time coordinates, and assuming accordingly that the density  $\rho$  and the velocity  $v$  of a fluid element are functions of  $\phi$ ,

$$\rho = \rho[\phi(x, t)], \quad v = v[\phi(x, t)], \quad (10.56)$$

equations (10.54a) and (10.54b), in which the pressure  $p$  is eliminated by the substitution of (10.54c), become

$$\rho_{,\phi} \phi_{,t} + v \rho_{,\phi} \phi_{,x} + \rho v_{,\phi} \phi_{,x} = 0, \quad (10.57a)$$

$$v_{,\phi} \phi_{,t} + v v_{,\phi} \phi_{,x} + c^2 \rho^{-1} \rho_{,\phi} \phi_{,x} = 0. \quad (10.57b)$$

The division of both equations by  $\phi_{,x}$  and considering that  $\phi_{,t} / \phi_{,x} = - \frac{\partial x}{\partial t} \Big|_{\phi}$

(obtained by eliminating the total exact derivative of  $\phi$ ) leads to

$$\left[ v - \frac{\partial x}{\partial t} \Big|_{\phi} \right] \rho_{,\phi} + \rho v_{,\phi} = 0, \quad (10.58a)$$

$$c^2 \rho^{-1} \rho_{,\phi} + \left[ v - \frac{\partial x}{\partial t} \Big|_{\phi} \right] v_{,\phi} = 0, \quad (10.58b)$$

Finally, the substitution of  $\rho_{,\phi}$ , by its expression deduced from equation (10.58b), into equation (10.58a) gives

$$\left( c^2 - \left[ v - \frac{\partial x}{\partial t} \right]_{\phi} \right)^2 \rho v_{,\phi} = 0, \quad (10.59a)$$

$$\text{or } \frac{\partial x}{\partial t} \Big|_{\phi} = v \pm c. \quad (10.59b)$$

Additionally, any of the two equations (10.58) gives

$$\rho v_{,\phi} = \pm c \rho_{,\phi}. \quad (10.60)$$

It is always possible to choose  $\phi$  so that  $\rho_{,\phi} = 1$ , for example, consequently  $\rho = \phi$ , which implies

$$v_{,\phi} = \pm \frac{c}{\rho} \text{ or } v = \pm \int_{\rho_0}^{\rho} \frac{c}{\rho} d\rho. \quad (10.61)$$

### 10.1.3.2. *Implicit solutions*

For an adiabatic transformation, equation (1.51) can be written as

$$c^2 = \left. \frac{\partial P}{\partial \rho} \right|_S = \gamma \frac{P_0}{\rho_0} \left( \frac{\rho}{\rho_0} \right)^{\gamma-1} = c_0^2 \left( \frac{\rho}{\rho_0} \right)^{\gamma-1}. \quad (10.62)$$

The substitution of equation (10.62) into equation (10.61) immediately leads to

$$v = \pm \int_{\rho_0}^{\rho} \frac{c}{\rho} d\rho = \pm \frac{2}{\gamma-1} (c - c_0)$$

$$\text{or } c = c_0 \pm \frac{\gamma-1}{2} v, \quad (10.63)$$

as seen in equation (10.55).

The substitution of equation (10.63) into equation (10.59) leads to

$$\left. \frac{\partial x}{\partial t} \right)_\phi = v \pm c = \pm c_0 \left( 1 \pm \frac{\gamma+1}{2} \frac{v}{c_0} \right). \quad (10.64)$$

Noting that  $v_{,t} = v_{,\phi} \phi_{,t}$  and  $v_{,x} = v_{,\phi} \phi_{,x}$ , one can also write that

$$\frac{v_{,t}}{v_{,x}} = \frac{\phi_{,t}}{\phi_{,x}} = - \left. \frac{\partial x}{\partial t} \right)_\phi. \quad (10.65)$$

The substitution of this result into equation (10.64) gives

$$v_{,t} \pm c_0 \left( 1 \pm \frac{\gamma+1}{2} \frac{v}{c_0} \right) v_{,x} = 0, \quad (10.66)$$

where the factor  $c_0 \left( 1 \pm \frac{\gamma+1}{2} \frac{v}{c_0} \right)$  represents the wave speed. (Note: the factor  $c$  in equation (10.63) does not denote this wave speed!)

Equation (10.66) in the form  $v_{,t} + \alpha(x, t)v_{,x} = 0$  has a set of solutions given by  $v(x, t) = f(x - \alpha t)$ . Indeed, at the second order of the acoustic quantities:

$$f_{,t} = -\alpha f' - t \alpha_{,t} f' \approx -\alpha f' + \beta \alpha t f'^2 \quad \text{and} \quad f_{,x} = f' - t \alpha_{,x} f' \approx f' - \beta t f'^2$$

with  $\beta = (\gamma + 1)/2$ .

Thus, for a sinusoidal source at  $x = 0$ ,

$$v(0, t) = V_0 \sin(\omega t),$$

and the implicit solution, written for a propagation in the positive  $x$ -direction for example, is

$$v(x, t) = V_0 \sin \left[ \omega \left[ t - \frac{x}{c_0} \left( 1 + \frac{\gamma+1}{2} \frac{v}{c_0} \right)^{-1} \right] \right]. \quad (10.67)$$

The fact that the relationship between  $\rho$  and  $p$  is not linear results in  $c \neq c_0$  and, more precisely, in the fact that the motion of a fluid element induced by the propagation of a wave contributes (by its own velocity  $v$ ) to the speed of propagation of the wave.

In Figure 10.5, the distortion of the wave of speed  $v$  with respect to time is represented only up to the discontinuity (shock wave) since the wave profile beyond this point has no physical meaning. In reality, the solution (10.67) of the system of equations (10.54) is not acceptable once the shock wave distortion occurs. It is therefore wise to limit the analysis to the region of space where the wave is continuous. In practice, the dissipation effects become more important than the non-linear effects at the vicinity of the discontinuity, which not considered in this section.

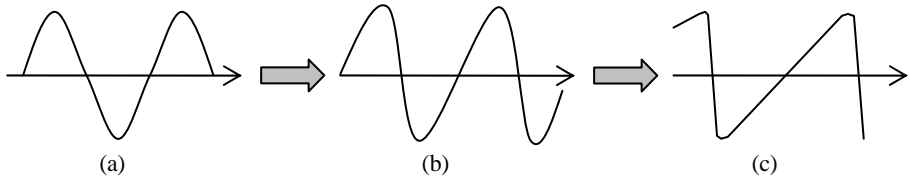

**Figure 10.5.** Distortion of the wave during the propagation (non-dissipative fluid)

To determine the coordinate  $\tilde{x}$  where the discontinuity occurs, one needs to observe that the distance traveled by a neutral point of the wave during the period  $\tilde{x}/c_0$ ,

$$c_0 \frac{\tilde{x}}{c_0},$$

subtracted from the distance traveled by the crest of the wave in the same period of time

$$c_0 \left( 1 + \frac{\gamma+1}{2} \frac{V_0}{c_0} \right) \frac{\tilde{x}}{c_0},$$

is equal to a quarter of the wavelength

$$\frac{\gamma+1}{2} V_0 \frac{\tilde{x}}{c_0} = \frac{\lambda_0}{4} \approx \frac{c_0}{\omega} = \frac{1}{k_0},$$

and, finally, that

$$\tilde{x} \approx \frac{2c_0}{(\gamma+1)k_0 V_0} = \frac{1}{k_0 \beta M_a}. \quad (10.68)$$

The parameters  $\beta = (\gamma+1)/2$  and  $M_a = V_0/c_0$  have already been introduced.

10.1.3.3. *Fubini's solutions to the implicit equations*

As seen above, the domain of validity of the proposed solution is given by

$$0 < x < \tilde{x}.$$

If one starts from the solution (10.67) where the parameter  $\beta = (\gamma + 1)/2$  is replaced by  $1 + B/(2A)$  (equation (10.22)),

$$v(x, t) = V_0 \sin \left( \omega t - \frac{\omega x}{c_0} \left[ 1 + \left( 1 + \frac{B}{2A} \right) \frac{v}{c_0} \right]^{-1} \right),$$

and assumes that  $\left( 1 + \frac{B}{2A} \right) \frac{v}{c_0} \approx \beta M_a \ll 1$ , one can derive the following solution:

$$v(x, t) = V_0 \sin \left[ \omega \left( t - \frac{x}{c_0} \left[ 1 - \frac{v}{c_0} \left( 1 + \frac{B}{2A} \right) + \dots \right] \right) \right]. \quad (10.69)$$

This expression can also be written, denoting  $W = v/V_0$  and  $\sigma = x/\tilde{x}$ , in the form

$$W = \sin(\omega t - k_0 x + \sigma W),$$

which Fourier series expansion:

$$W = \sum_{n=1}^{\infty} B_n \sin [n(\omega t - k_0 x)],$$

is obtained by calculating the expansion coefficients

$$B_n = \frac{1}{\pi} \int_0^{2\pi} W \sin n(\omega t - k_0 x) d(\omega t - k_0 x),$$

using the following new variables

$$W = \sin \xi \text{ and } \xi - \sigma \sin \xi = \omega t - k_0 x.$$

This leads to

$$\begin{aligned}
 B_n &= \frac{1}{\pi} \int_0^{2\pi} (1 - \sigma \cos \xi) \sin \xi \sin [n(\xi - \sigma \sin \xi)] d\xi, \\
 &= \frac{1}{\pi} \int_0^\pi \cos [(n-1)\xi - n\sigma \sin \xi] d\xi - \frac{1}{\pi} \int_0^\pi \cos [(n+1)\xi - n\sigma \sin \xi] d\xi \\
 &\quad - \frac{\sigma}{2\pi} \int_0^\pi \cos [(n-2)\xi - n\sigma \sin \xi] d\xi - \frac{\sigma}{2\pi} \int_0^\pi \cos [(n+2)\xi - n\sigma \sin \xi] d\xi, \\
 &= J_{n-1}(n\sigma) - J_{n+1}(n\sigma) - \frac{\sigma}{2} J_{n-2}(n\sigma) + \frac{\sigma}{2} J_{n+2}(n\sigma) = \frac{2}{n\sigma} J_n(n\sigma),
 \end{aligned}$$

where the functions  $J_n$  are Bessel's cylindrical functions of the first kind. The solution (10.69) then becomes (for  $\sigma = x/\tilde{x} < 1$ )

$$\frac{v}{V_0} = \sum_{n=1}^{\infty} \frac{2}{n\sigma} J_n(n\sigma) \sin [n(\omega t - k_0 x)], \quad (10.70)$$

which is known as Fubini's solution.

This result shows that harmonics are induced by the non-linear effects that result in a decreased amplitude of the fundamental harmonic ( $n = 1$ ).

Note: the substitution of  $(\gamma - 1)$  by  $B/A$  (equation (10.9b)) into equation (10.62),

$$dP)_S = c_0^2 \left( \frac{\rho}{\rho_0} \right)^{B/A} d\rho)_S,$$

and the integration of this expression from the state at rest  $(P_0, \rho_0)$  to the current state  $(P, \rho)$ , leads to the so-called Tait's equations

$$\begin{aligned}
 P - P_0 &= \frac{\rho_0 c_0^2}{1 + B/A} \left[ \left( \frac{\rho}{\rho_0} \right)^{1+B/A} - 1 \right], \\
 \text{or } \frac{\rho}{\rho_0} &= \left[ 1 + \left( 1 + \frac{B}{A} \right) \frac{P - P_0}{\rho_0 c_0^2} \right]^{1/(1+B/A)}.
 \end{aligned}$$



### 10.1.4. *Bürger's equation for plane waves in dissipative (visco-thermal) media*

#### 10.1.4.1. *Plane wave in a circular tube: effect of the visco-thermal boundary layers*

It is now clear, from the previous section (10.1.2 and 10.1.3), that the non-linear effects induce harmonics in the propagating wave. An appropriate presentation of the problem and its solution should therefore consider the equations in the time domain. Nevertheless, it is convenient to (re-)introduce the notion of equivalent acoustic impedance  $Z_a$  of the tube walls to account for the visco-thermal boundary layers' effects on the propagation of acoustic plane waves. The corresponding specific admittance, in grazing incidence, is in the Fourier domain:

$$\frac{\rho_0 c_0}{Z_a} = \sqrt{ik_0 \ell'_{vh}},$$

where  $\sqrt{\ell'_{vh}}$  is a simple notation denoting  $\sqrt{\ell'_v} + (\gamma - 1) \sqrt{\ell'_h}$ ,

with  $\ell'_v = \mu / (\rho_0 c_0)$ ,  $\mu$  being the coefficient of shear viscosity,

and  $\ell'_h = \lambda / (\rho_0 c_0 C_P)$ ,  $\lambda$  being the coefficient of thermal conduction,

while the thicknesses of the associated boundary layers are given by

$$\delta_h = \sqrt{2\ell'_h / k_0} \quad \text{and} \quad \delta_v = \sqrt{2\ell'_v / k_0}.$$

More precisely, the effect of the boundary layers can be expressed in terms of acoustic particle radial velocity  $v_R$  at the boundary layers of the tube (of radius  $R$ ), the expression of which in the time domain is in the form

$$v_R = \text{FT}^{-1} [p_\omega / Z_a] = \text{FT}^{-1} \left[ \sqrt{ik_0 \ell'_{vh}} \frac{p_\omega}{\rho_0 c_0} \right],$$

where  $\text{FT}^{-1}$  denotes the inverse Fourier transform.

Consequently, the associated acoustic volume velocity  $q$ , that is the volume of fluid introduced in the considered domain per unit of volume and time (for a length of tube  $dx$ ), can be written as

$$\begin{aligned}
 q &= \frac{(-v_R) 2\pi R \, dx}{\pi R^2 \, dx} = -\frac{2}{R} \frac{\sqrt{\ell'_{vh}}}{\rho_0 c_0^{3/2}} \text{TF}^{-1}(\sqrt{i\omega} p_\omega), \\
 &= -\frac{2}{R} \frac{\sqrt{\ell'_{vh}}}{\rho_0 c_0^{3/2}} \partial_t^{1/2} p(x, t),
 \end{aligned}
 \tag{10.71a}$$

where the operator  $\partial_t^{1/2}$ , associated with the Fourier domain factor  $\sqrt{i\omega}$ , denotes the fractional  $(1/2)^{\text{th}}$  derivative defined by the convolution product (section 10.1.4, equation (10.106))

$$\partial_t^{1/2} p \equiv \frac{1}{\sqrt{\pi}} \int_0^t \frac{1}{(t-\sigma)^{1/2}} \frac{\partial p(\sigma)}{\partial \sigma} d\sigma.
 \tag{10.71b}$$

In equation (10.71a), the acoustic pressure  $p$  can be replaced by its expression obtained from the linear form of the mass conservation equation (since the factor  $q$  remains a small perturbation of the motion considered). Thus, the substitution of:

$$p \approx -\rho_0 c_0^2 \partial_t^{-1} \partial_x v$$

where  $v$  denotes the particle velocity of the acoustic plane wave about the  $x$ -axis of the tube, into equation (10.71) leads to the following equation

$$q \approx \frac{2}{R} \sqrt{c_0 \ell'_{vh}} \partial_t^{-1/2} \partial_x v,
 \tag{10.72a}$$

where the operator  $\partial_t^{-1/2}$  denotes the fractional indefinite integral defined by the convolution product (section 10.1.4, equation (10.104))

$$\partial_t^{-1/2} p \equiv \frac{1}{\sqrt{\pi}} \int_0^t \frac{p(\sigma)}{(t-\sigma)^{1/2}} d\sigma.
 \tag{10.72b}$$

Note:  $\text{TF}(\partial_t^{-1/2} p) = \frac{p}{\sqrt{i\omega}}.$

10.1.4.2. *Equations of motions of the plane wave in the tube*

If the hypothesis that the motion is irrotational ( $\text{rot } \vec{v} = \vec{0}$ ) is adopted, the fundamental equations of motions are given by equations (2.32), (2.33), (2.44), (2.5) and (1.20) and by considering equations (1.10) and (1.98),

$$\rho \frac{d\vec{v}}{dt} = -\text{grad } P + \left( \eta + \frac{4}{3}\mu \right) \Delta \vec{v}, \quad (10.73)$$

$$\frac{d\rho}{dt} + \rho \text{div } \vec{v} = \rho q, \quad \text{where } q \text{ is given by equation (10.72a)}, \quad (10.74)$$

$$\rho T \frac{dS}{dt} = \lambda \Delta T, \quad (10.75)$$

$$d\rho = \rho \chi_T (dP - P\beta dT),$$

$$\text{or in first approximation } \frac{(\gamma-1)}{\gamma} \frac{dT}{T} = \frac{-\alpha}{\rho_0 C_p} \left( \frac{c_0^2}{\gamma} d\rho - dP \right), \quad (10.76)$$

$$dS = \frac{\hat{\beta} \chi_T}{(\gamma-1)\rho} \left( dP - \frac{\gamma}{\rho \chi_T} d\rho \right), \quad \text{where } \hat{\beta} = P\beta. \quad (10.77a)$$

Equation (10.77a) can be written in any of the following forms for a perfect gas (equations (1.49) and (1.51))

$$dS = C_v \left( \frac{dP}{P} - \gamma \frac{d\rho}{\rho} \right), \quad (10.77b)$$

$$\frac{P}{P_0} = \left( \frac{\rho}{\rho_0} \right)^\gamma \exp \left( \frac{S - S_0}{C_v} \right). \quad (10.77c)$$

It is convenient to assume here that the factors related to the non-linearity, volume viscosity (equation (10.73)), thermal conduction (equation (10.75)), and boundary layers (10.74) are small compared to the other factors (linear ones). Hence, all the above terms can be expanded in series limited to the lowest order (in practice, such transformation should be preceded by an analysis of the orders of magnitude as in section 10.1.2.2). Consequently, the propagation being assumed in one dimension and equations (10.76) and (10.77a) being taken into account, equations (10.73) to (10.75) are written, respectively, as

$$\frac{dv}{dt} + \frac{1}{\rho} \partial_x P - c_0 \ell_v \partial_{xx}^2 v = 0, \quad (10.78)$$

$$\frac{1}{\rho} \frac{d\rho}{dt} + \partial_x v - \frac{2}{R} \sqrt{c_0 \ell_{vh}'} \partial_t^{-1/2} \partial_x v = 0, \quad (10.79)$$

$$\frac{1}{\rho} \frac{d\rho}{dt} - \frac{\chi_T}{\gamma} \frac{dP}{dt} - \frac{(\gamma-1) \ell_h}{c_0} \partial_t \partial_x v = 0, \quad (10.80)$$

where the factor  $(\lambda \partial_{xx}^2 T)$  has been substituted by an expression obtained from equation (10.76) taking into account the equation  $dP = c_0^2 d\rho$  and Euler's linear equation

$$\begin{aligned} -\frac{\gamma-1}{\gamma \hat{\beta}} \frac{\lambda}{T} \partial_{xx}^2 T &= \frac{\alpha c_0}{\hat{\beta}} \ell_h \left( \frac{c_0^2}{\gamma} \partial_{xx}^2 \rho - \partial_{xx}^2 P \right) \approx \frac{\alpha c_0}{\hat{\beta}} \ell_h \left( -\frac{\gamma-1}{\gamma} \partial_{xx}^2 P \right), \\ &= \frac{\alpha c_0}{\hat{\beta}} \ell_h \frac{\gamma-1}{\gamma} \rho_0 \partial_t \partial_x v \approx \frac{\gamma-1}{\gamma} \rho_0 c_0 \chi_T \ell_h \partial_t \partial_x v, \\ &= \frac{\gamma-1}{c_0} \ell_h \partial_t \partial_x v. \end{aligned} \quad (10.81)$$

The elimination of the factor  $\left( \frac{1}{\rho} \frac{d\rho}{dt} \right)$  by the substitution of expression (10.80) into equation (10.79) gives

$$\frac{\chi_T}{\gamma} \frac{dP}{dt} + \frac{\gamma-1}{c_0} \ell_h \partial_t \partial_x v + \partial_x v - \frac{2}{R} \sqrt{c_0 \ell_{vh}'} \partial_t^{-1/2} \partial_x v = 0. \quad (10.82)$$

If one considers that equation (10.78) is written at the order adapted to each situation, the factor  $\left( \frac{\chi_T}{\gamma} \frac{dP}{dt} \right)$  can be written as

$$\begin{aligned} \frac{\chi_T}{\gamma} \frac{dP}{dt} &= \frac{\chi_T}{\gamma} (\partial_t P + v \partial_x P) \approx \frac{\chi_T}{\gamma} (\partial_t P - \rho_0 v \partial_t v), \\ &= \frac{\chi_T}{\gamma} \left[ \partial_x^{-1} \partial_t \left( -\rho \frac{dv}{dt} + \rho_0 c_0 \ell_v \partial_{xx}^2 v \right) - \rho_0 v \partial_t v \right], \\ &= \frac{\chi_T}{\gamma} \left[ -\partial_t \partial_x^{-1} \left( \rho \frac{dv}{dt} \right) - \rho_0 v \partial_t v + \rho_0 c_0 \ell_v \partial_t \partial_x v \right]. \end{aligned}$$

Also, since equation (10.77c) taken for a perfect gas leads to

$$\frac{\chi_T}{\gamma} = \chi_s = \frac{1}{\rho(dP/d\rho)_S} = \frac{1}{\gamma P_0} \left(\frac{\rho}{\rho_0}\right)^{-\gamma} \approx \frac{1}{\rho_0 c_0^2} \left(1 - \gamma \frac{\rho'}{\rho_0}\right),$$

one obtains

$$\begin{aligned} \frac{\chi_T}{\gamma} \frac{dP}{dt} &= -\frac{1}{c_0^2} \partial_x^{-1} \partial_{tt}^2 v + \frac{\gamma}{\rho_0 c_0^2} \rho' \partial_x^{-1} \partial_{tt}^2 v \\ &\quad - \frac{1}{\rho_0 c_0^2} \partial_x^{-1} \partial_t (\rho' \partial_t v + \rho_0 v \partial_x v) \\ &\quad + \frac{1}{\rho_0 c_0^2} [-\rho_0 v \partial_t v + \rho_0 c_0 \ell_v \partial_t \partial_x v]. \end{aligned} \tag{10.83}$$

Accordingly, equation (10.82) becomes

$$\begin{aligned} \partial_x^{-1} \left[ \partial_{xx}^2 - \frac{1}{c_0^2} \partial_{tt}^2 \right] v + \frac{\gamma}{\rho_0 c_0^2} \rho' \partial_x^{-1} \partial_{tt}^2 v - \frac{1}{\rho_0 c_0^2} \partial_x^{-1} \partial_t [\rho' \partial_t v + \rho_0 v \partial_x v] - \frac{1}{c_0^2} v \partial_t v \\ = -\frac{\ell_{vh}}{c_0} \partial_t \partial_x v + \frac{2}{R} \sqrt{c_0 \ell'_{vh}} \partial_t^{-1/2} \partial_x v, \end{aligned} \tag{10.84}$$

where  $\ell_{vh} = \ell_v + (\gamma - 1)\ell_h$  (equation (2.86)).

The first term on the left-hand side of equation (10.84) contains, in the brackets, the linear equation of propagation in a non-dissipative fluid while the two remaining terms on the left-hand side contain all the non-linear terms. The two terms on the right-hand side represent, respectively, the effects of bulk dissipation and the dissipation (and reaction) at the boundaries due to the visco-thermal effects. According to the value of the radius  $R$  of the tube (and to the frequency considered in the spectrum of the signal), one of these two factors is predominant. If  $R$  is large (plane wave in an infinite space), the volume dissipation term is the only one to consider.

At the lowest order, the acoustic particle velocity  $v$  is a function of two variables  $\theta_{\pm} = (t \pm x / c_0)$

$$v_{\pm} = v(\theta_{\pm}), \tag{10.85}$$

and  $c_0 \partial_x \approx \pm \partial_t$  or  $\partial_x^{-1} \approx \pm c_0 \partial_t^{-1}$ .

Consequently, at the lowest order, the equation of mass conservation is of the form

$$-\frac{1}{\rho_0} \partial_t \rho' \approx \partial_x v \quad \text{or} \quad -\frac{1}{\rho_0} \partial_t \rho' \approx \pm \frac{1}{c_0} \partial_t v, \quad (10.86)$$

thus, by integration

$$\frac{\rho'}{\rho_0} \approx \mp \frac{v}{c_0}. \quad (10.87)$$

Hence, the non-linear factor  $[\rho' \partial_t v + \rho_0 v \partial_x v]$  of equation (10.84) can be written as

$$\rho' \partial_t v + \rho_0 v \partial_x v \approx \rho' \partial_t v + \rho_0 \left( \mp \frac{c_0}{\rho_0} \rho' \right) \left( \pm \frac{1}{c_0} \partial_t v \right) = 0, \quad (10.88)$$

and the non-linear factor  $\rho' \partial_x^{-1} \partial_{tt}^2 v$  as  $\rho' \partial_x^{-1} \partial_{tt}^2 v \approx -\rho_0 v \partial_t v$ .

Finally, the substitution of equations (10.86) and (10.88) into equation (10.84) gives:

$$\partial_x^{-1} \left( \partial_{xx}^2 v - \frac{1}{c_0^2} \partial_{tt}^2 v \right) = \frac{\gamma+1}{c_0^2} v \partial_t v \mp \frac{\ell_{vh}}{c_0^2} \partial_{tt}^2 v \pm \frac{2}{R} \sqrt{\frac{\ell'_{vh}}{c_0}} \partial_t^{1/2} v. \quad (10.89)$$

The “upper” sign is associated with a propagation in the positive  $x$ -direction. When one is solving equation (10.89) (as for the forthcoming equation (10.90)), the particle velocity  $v$  can be replaced on the right-hand side by its approximated expression (equation (10.85)), but not on the left-hand side.

#### 10.1.4.3. *Bürger's equation for a plane wave in a circular guide*

In accordance with the conclusions in sections 10.1.2 and 10.1.3 relating to the distortion of the wave during propagation (thus in time) by non-linear effects, the wave profile is assumed depending only on the delayed time  $\theta_{\pm} = (t \pm x/c_0)$ , but is still assumed to be slowly varying in time (thus in space) to take into account the non-linear distortion and attenuation of the wave profile, and therefore depends also on the time variable

$$\sigma = \varepsilon t,$$

where  $\varepsilon$  denotes a small parameter measuring the order of magnitude of the non-linearity, defined by (for example)

$$\varepsilon = M_a \beta,$$

where  $M_a$  is the acoustic Mach number providing a measure of the magnitude of the acoustic particle velocity with respect to the adiabatic velocity ( $M_a = V_0/c_0$ ) and where  $\beta = (\gamma + 1)/2$  is called the parameter of non-linearity.

Accordingly, the non-dimensional particle velocity can be written as

$$w(\sigma, \theta_{\pm}) = v(\sigma, \theta_{\pm})/c_0,$$

and consequently

$$\frac{1}{c_0} \partial_t v = \partial_t w = (\varepsilon \partial_{\sigma} + \partial_{\theta_{\pm}}) w,$$

$$\frac{1}{c_0} \partial_{tt}^2 v = \partial_{tt}^2 w = (\varepsilon^2 \partial_{\sigma\sigma}^2 + \partial_{\theta_{\pm}\theta_{\pm}}^2 + 2\varepsilon \partial_{\sigma} \partial_{\theta_{\pm}}) w \approx (\partial_{\theta_{\pm}\theta_{\pm}}^2 + 2\varepsilon \partial_{\sigma} \partial_{\theta_{\pm}}) w,$$

$$\partial_x v = c_0 \partial_x w = \pm \partial_{\theta_{\pm}} w,$$

$$\frac{1}{c_0^2} \partial_x^{-1} \partial_{tt}^2 v = \frac{1}{c_0} \partial_x^{-1} \partial_{tt}^2 w = (\pm \partial_{\theta_{\pm}}^{-1}) (\partial_{\theta_{\pm}\theta_{\pm}}^2 + 2\varepsilon \partial_{\sigma} \partial_{\theta_{\pm}}) w = \pm (\partial_{\theta_{\pm}} + 2\varepsilon \partial_{\sigma}) w.$$

The substitution of the above results into equation (10.89), and ignoring the high orders, directly gives

$$\mp \partial_{\tau} w = \beta w \partial_{\theta_{\pm}} w \mp \frac{1}{2} \frac{\ell_{vh}}{c_0} \partial_{\theta_{\pm}\theta_{\pm}}^2 w \pm \frac{1}{R} \sqrt{c_0 \ell'_{vh}} \partial_{\theta_{\pm}}^{1/2} w, \quad (10.90)$$

with  $w(\tau, \theta_{\pm}) = v(\tau, \theta_{\pm})/c_0,$

where  $\tau = \sigma/\varepsilon = t$  ( $\partial_{\tau} = \varepsilon \partial_{\sigma}$ ) denotes the time,

and  $\theta_{\pm} = t \pm x/c_0$  denotes the delayed time. (The left-hand side term  $\partial_{\tau} w$  can be replaced by  $c_0 \partial_x w$  in equation (10.90).)

Equation (10.90) is called the non-dimensional Bürger's equation for a plane wave propagating in the negative (upper sign) or positive (lower sign) x-direction in a tube with a circular cross-section. The search of a solution to this equation is not detailed in

this book. Only the fundamental basis of the method proposed by Hopf and Cole that considers the case of an infinite plane wave ( $R \rightarrow \infty$ ) is presented in the next section.

Note: since the order of magnitude of the left-hand side term of equation (10.89) is roughly the same as the orders of magnitude of the non-linear, dissipative and dispersive terms on the right-hand side, the operator  $\partial_x^{-1}$  can be replaced by  $\pm c_0 \partial_{\theta_{\pm}}^{-1}$ . The substitution of a form of solution, the profile of which varies slowly in space (during the propagation) and in time (transient state for example),  $v = v(\varepsilon_1 t, \varepsilon_2 x, \theta_{\pm})$ , where  $\varepsilon_i$  are small parameters leads to

$$c_0 \partial_x w \mp \partial_t w = \beta w \partial_{\theta_{\pm}} w \mp \frac{1}{2} \frac{\ell_{vh}}{c_0} \partial_{\theta_{\pm} \theta_{\pm}}^2 w \pm \frac{1}{R} \sqrt{c_0 \ell'_{vh}} \partial_{\theta_{\pm}}^{1/2} w. \quad (10.91)$$

10.1.4.4. Hopf and Cole approach to calculate the solution to B urger’s equation for a plane wave in an infinite medium

The B urger’s equation (10.90) in an infinite medium (where  $R \rightarrow \infty$ ) is in the form

$$\mp \partial_{\tau} w = \beta w \partial_{\theta} w \mp \frac{1}{2} \frac{\ell_{vh}}{c_0} \partial_{\theta\theta}^2 w.$$

By changing the variables to  $u = \beta \tau$  and changing the function

$$w = \mp \frac{\ell_{vh}}{\beta c_0} \partial_{\theta} (\log \xi) = \mp \frac{\ell_{vh}}{\beta c_0} \frac{\partial \theta \xi}{\xi},$$

this equation becomes

$$\frac{1}{\xi} \left( \partial_{\theta} - \frac{\partial \theta \xi}{\xi} \right) \left( \partial_u \xi - \frac{\ell_{vh}}{2\beta c_0} \partial_{\theta\theta}^2 \xi \right) = 0 \text{ or } \partial_{\theta} \left[ \frac{1}{\xi} \left( \partial_u \xi - \frac{\ell_{vh}}{2\beta c_0} \partial_{\theta\theta}^2 \xi \right) \right] = 0,$$

resulting in

$$\partial_{\theta\theta}^2 \xi - \chi_0 \partial_u \xi = 0, \quad (10.92)$$

where  $\chi_0 = 2\beta c_0 / \ell_{vh} = \frac{(\gamma+1)c_0}{\ell_v + (\gamma-1)\ell_h} = \frac{(\gamma+1)\rho_0 c_0^2}{\eta + \frac{4}{3}\mu + (\gamma-1)\frac{\lambda}{C_p}}$ .



Equation (10.92) is a linear diffusion equation. The associated Green's function satisfies

$$\partial_{\theta\theta}^2 g - \chi_0 \partial_u g = -\delta(\theta - \theta_0) \delta(u - u_0), \quad (10.93)$$

which the solution to which, in infinite space, is

$$g(\theta, u; \theta_0, u_0) = \frac{1}{\sqrt{4\pi\chi_0(u - u_0)}} \exp\left(\frac{\chi_0}{4} \frac{(\theta - \theta_0)^2}{u - u_0}\right). \quad (10.94)$$

The solutions to equation (10.92) can be derived by adopting the usual approaches and using the Green's function (equation (10.94)). Numerous studies have been carried out on Bürger's equation corroborating and improving the results mentioned at the end of sections 10.1.2 and 10.1.3. The interpretations of the phenomena concerning the propagation of the plane wave described by these solutions can be summarized in a succinct way by identifying three successive regions of propagation:

- i) the initially sinusoidal wave is distorted, tending toward the shape of a shock wave by induction of non-linear harmonics;
- ii) the wave then conserves a loose "saw-like shape", the dissipative and non-linear phenomena reaching equilibrium between their opposing effects since high frequencies are attenuated more rapidly than low frequencies;
- iii) the visco-thermal dissipation preferentially attenuates the amplitudes of the harmonics in such way that only the fundamental harmonic subsists (attenuated) and decreases exponentially with respect to time.

#### 10.1.4.5. Digression on the indefinite integral and fractional derivatives of $(1/2)^{\text{th}}$ order

The object of this section is to introduce the notions of indefinite integral and fractional derivative of the order  $(1/2)$  used in section 10.1.4 in equations (10.71) and (10.72). The presentation begins with the generalized Abel's integral equation which, by definition, is

$$\int_0^x \frac{\varphi(t)}{(x-t)^\alpha} dt = f(x), \quad 0 < \alpha < 1. \quad (10.95)$$

This integral equation has a solution in the entire interval  $\alpha \in (0,1)$ , even though for  $\alpha = 1/2$  the function  $(x-t)^{-\alpha}$  does not belong to Hilbert's space.

The replacement of  $x$  with  $s$ , and multiplying by  $\frac{ds}{(x-s)^{1-\alpha}}$  and integrating with respect to  $s$  from 0 to  $x$  gives

$$\int_0^x \frac{ds}{(x-s)^{1-\alpha}} \int_0^s \frac{\varphi(t)}{(s-t)^\alpha} dt = \int_0^x \frac{f(s)}{(x-s)^{1-\alpha}} ds, \quad (10.96)$$

or, by inverting the order of integration in the right-hand side ( $0 \leq t \leq s \leq x$ ),

$$\int_0^x \varphi(t) dt \int_t^x \frac{ds}{(x-s)^{1-\alpha} (s-t)^\alpha} = \int_0^x \frac{f(s)}{(x-s)^{1-\alpha}} ds. \quad (10.97)$$

The change of the variable to  $s = t + y(x-t)$  in the first term gives

$$\int_t^x \frac{ds}{(x-s)^{1-\alpha} (s-t)^\alpha} = \int_0^1 \frac{dy}{y^\alpha (1-y)^{1-\alpha}} = \frac{\pi}{\sin(\alpha\pi)}. \quad (10.98)$$

The substitution of equation (10.98) into equation (10.97) leads to

$$\int_0^x \frac{f(s)}{(x-s)^{1-\alpha}} ds = \frac{\pi}{\sin(\alpha\pi)} \int_0^x \varphi(t) dt, \quad (10.99)$$

resulting, by differentiation, in the solution to equation (10.95)

$$\frac{d}{dx} \int_0^x \frac{f(s)}{(x-s)^{1-\alpha}} ds = \frac{\pi}{\sin(\alpha\pi)} \varphi(x). \quad (10.100)$$

The substitution of equation (10.100) into equation (10.96) gives

$$\frac{d}{dx} \int_0^x \frac{ds}{(x-s)^{1-\alpha}} \int_0^s \frac{dt}{(s-t)^\alpha} \varphi(t) = \frac{\pi}{\sin(\alpha\pi)} \varphi(x). \quad (10.101)$$

In the particular case where  $\alpha = 1/2$ , equation (10.101) becomes

$$\frac{d}{dx} \frac{1}{\sqrt{\pi}} \int_0^x \frac{ds}{(x-s)^{1/2}} \frac{1}{\sqrt{\pi}} \int_0^s \frac{dt}{(s-t)^{1/2}} \varphi(t) = \varphi(x), \tag{10.102}$$

which leads directly to the interpretation of the operator

$$\frac{1}{\sqrt{\pi}} \int_0^u \frac{d\xi}{(u-\xi)^{1/2}} \tag{10.103}$$

as the fractional operator of integration  $\left(\frac{d}{du}\right)^{-1/2}$ .

Consequently, the Fourier transform of

$$\frac{1}{\sqrt{\pi}} \int_0^t \frac{f(\tau) d\tau}{(t-\tau)^{1/2}} = \frac{1}{\sqrt{\pi}} \int_0^t \frac{f(t-\sigma)}{\sqrt{\sigma}} d\sigma \tag{10.104}$$

is given by

$$\text{FT} \left[ \frac{1}{\sqrt{\pi}} \int_0^t \frac{f(\tau) d\tau}{(t-\tau)^{1/2}} \right] = \text{FT} \left[ \frac{1}{\sqrt{\pi}} \int_0^t \frac{f(t-\sigma)}{\sqrt{\sigma}} d\sigma \right] = (i\omega)^{-1/2} \tilde{f}(\omega), \tag{10.105}$$

where  $\tilde{f}$  denotes the Fourier transform of  $f(t)$ . Inversely, the inverse Fourier transform of  $(i\omega)^{1/2} \tilde{f}(\omega)$  gives the  $(1/2)^{\text{th}}$  fractional indefinite integral of the derivative of  $f$ , thus the  $(1/2)^{\text{th}}$  order derivative of  $f$  which is then written as

$$\frac{\partial^{1/2} f}{\partial t^{1/2}} = \frac{1}{\sqrt{\pi}} \int_0^t \frac{1}{(t-\tau)^{1/2}} \frac{\partial f(\tau)}{\partial \tau} d\tau. \tag{10.106}$$

## 10.2. Introduction to acoustics in fluids in subsonic uniform flows

The following study is limited to the propagation in homogeneous and non-dissipative fluids with a constant subsonic relative velocity.

### 10.2.1. Doppler effect

Two Galilean frames and associated ortho-normal coordinate systems are considered. One, denoted (S), is assumed stationary and bound to the sound source considered, while the other, denoted (S'), is bound to the fluid in motion and therefore assumed in motion with the constant velocity  $\vec{U}$  with respect to the first one (Figure 10.6).

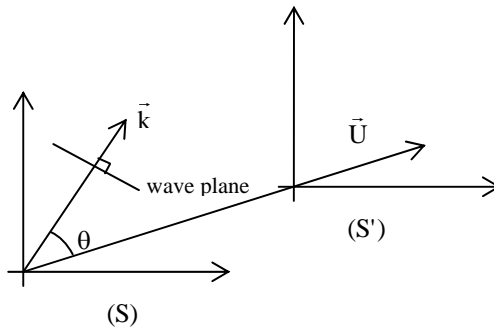

**Figure 10.6.** Coordinate systems bound to the sound source (S) and to the fluid in motion (S')

The time origin is chosen so that both coordinate systems coincide at  $t = 0$ , and the sound source is assumed radiating a sinusoidal signal.

The properties of the acoustic wave observed in both systems are presented here.

i) The wave form is invariant under a change of coordinate system. In other words, an observer “sees” a sinusoidal wave from both systems, written in the general form

$$p = P_0 e^{i(\omega t - \vec{k}_0 \cdot \vec{r})} \text{ in (S),} \quad (10.107a)$$

$$p' = P'_0 e^{i(\omega' t' - \vec{k}'_0 \cdot \vec{r}')} \text{ in (S').} \quad (10.107b)$$

ii) At a given point in space and time, the wave phase is the same for all observers. In other words, if at the four-dimensional point  $(\vec{r}, t)$  for an observer  $O$  bound to  $(S)$  the wave presents a maximum (for example), at the same point, written  $(\vec{r}', t')$  for an observer  $O'$  bound to  $(S')$ , the wave presents also a maximum. This property can be written as

$$\omega t - \vec{k}_0 \cdot \vec{r} = \omega' t' - \vec{k}'_0 \cdot \vec{r}', \quad \forall (\vec{r}, t). \quad (10.108)$$

iii) The distance between two consecutive points of equal phase is the same for any given observer and results in the equality of the wavelengths measured in both coordinate systems

$$\lambda = \lambda', \text{ thus } |\vec{k}_0| = |\vec{k}'_0| \quad (k_0 = 2\pi/\lambda). \quad (10.109)$$

iv) The direction of the wave is the same whatever system the observer is in,

$$\frac{\vec{k}_0}{k_0} = \frac{\vec{k}'_0}{k'_0}.$$

Accordingly, by considering the property given by equation (10.109), one obtains

$$\vec{k}_0 = \vec{k}'_0. \quad (10.110)$$

v) The substitution of the transformation law of a vector's coordinates in the Galilean coordinate systems

$$\begin{aligned} t &= t', \\ \vec{r} &= \vec{r}' + \vec{U} t, \end{aligned} \quad (10.111)$$

into equation (10.108) gives

$$\omega t - \vec{k}_0 \cdot \vec{r} = \omega' t - \vec{k}'_0 \cdot (\vec{r}' + \vec{U} t) \text{ and, finally, } \omega = \omega' + \vec{k}'_0 \cdot \vec{U}. \quad (10.112)$$

If " $c_0$ " denotes the speed of sound "at rest" (meaning the speed of sound in the system bound to the fluid),

$$k'_0 = \frac{\omega'}{c_0},$$

and, if one considers that  $k_0 = k'_0$  (equation (10.109)), equation (10.112) becomes

$$\omega = \omega'(1 + M \cos \theta), \quad (10.113)$$

where  $M = U/c_0$  (Mach number, here smaller than one), and  $\theta = (\vec{k}_0, \vec{U})$ , leading finally to

$$k_0 = \frac{\omega}{c_0(1 + M \cos \theta)}, \quad (10.114)$$

where  $c_0(1 + M \cos \theta)$  denotes the wave speed measured in the stationary coordinate system (law of addition of velocities).

In the particular case where  $\theta = 0$  or  $\theta = \pi$ , the relationship (10.113) leads to the classic Doppler law

$$\omega = \omega'(1 \pm M). \quad (10.115)$$

### 10.2.2. Equations of motion

The linear equations of (acoustic) isentropic motion in a perfect fluid with constant characteristics in absence of sources and in motion with a constant speed  $\vec{U}$  are those given in Chapter 1, equations (1.29), (1.31) and (1.55),

$$\left( \frac{\partial}{\partial t} + \vec{U} \cdot \text{grad} \right) \rho' + \rho_0 \text{div} \vec{v} = 0, \quad (10.116a)$$

$$\left( \rho_0 \frac{\partial}{\partial t} + \vec{U} \cdot \text{grad} \right) \vec{v} + \text{grad} p = 0, \quad (10.116b)$$

$$p = c_0^2 \rho'. \quad (10.116c)$$

The associated equation of propagation (in terms of pressure) is then written (equation (1.45)) as

$$\Delta p - c_0^{-2} \left( \frac{\partial}{\partial t} + \vec{U} \cdot \text{grad} \right)^2 p = 0. \quad (10.117)$$

Note 1: the substitution of the form of solution  $p = \exp[i(\omega t - \vec{k}_0 \cdot \vec{r})]$  into equation (10.117) gives the equation of dispersion

$$k_0^2 = \left( \frac{\omega}{c_0} - \frac{\vec{U}}{c_0} \cdot \vec{k}_0 \right)^2.$$

By finding the solution to this equation, one obtains the result of the previous paragraph,

$$k_0 = \frac{\omega}{c_0(1 + M \cos \theta)}.$$

Note 2: these equations can also be derived from the equations of motion in the absence of any flow in the coordinate system (S') bound to the fluid

$$\frac{\partial p}{\partial t'} + \rho_0 \sum_i \frac{\partial v_i}{\partial x'_i} = 0, \quad (10.118a)$$

$$\rho_0 \frac{\partial v_i}{\partial t'} + \frac{\partial p}{\partial x'_i} = 0, \quad (10.118b)$$

$$p = c_0^2 \rho', \quad (10.118c)$$

by changing the variables (Galileo's transformation) to

$$x_i = x'_i + U_i t' \quad \text{and} \quad t = t' \quad (\text{with } \vec{U} = \text{constant}),$$

which, for any given function  $f$  of space and time, gives

$$\frac{\partial f}{\partial x'_i} = \sum_j \frac{\partial f}{\partial x_j} \frac{\partial x_j}{\partial x'_i} + \frac{\partial f}{\partial t} \frac{\partial t}{\partial x'_i} = \frac{\partial f}{\partial x_i}, \quad (10.119)$$

(the spatial derivative operator is invariant), and

$$\frac{\partial f}{\partial t'} = \frac{\partial f}{\partial t} \frac{\partial t}{\partial t'} + \sum_i \frac{\partial f}{\partial x_i} \frac{\partial x_i}{\partial t'} = \frac{\partial f}{\partial t} + \sum_i U_i \frac{\partial f}{\partial x_i}, \quad (10.120a)$$

thus

$$\frac{\partial}{\partial t'} = \frac{\partial}{\partial t} + \vec{U} \cdot \text{grad}. \quad (10.120b)$$

The substitution of equations (10.119) and (10.120) into equations (10.118) leads immediately to equations (10.116).

### 10.2.3. Integral equations of motion and Green's function in a uniform and constant flow

#### 10.2.3.1. Acoustic problems in stationary coordinate systems

The equation of propagation in a uniform flow of velocity  $\vec{U}$  in a perfect fluid (equation (1.45) or (10.117) with non-homogeneous source term in the right-hand side) is

$$\left[ \Delta - c_0^{-2} \frac{d^2}{dt^2} \right] \Psi(\vec{r}, t) = -f(\vec{r}, t), \quad (10.121a)$$

$$\text{with } \frac{d^2}{dt^2} = \left( \frac{\partial}{\partial t} + \vec{U} \cdot \text{grad} \right)^2, \quad (10.121b)$$

where  $\Psi$  denotes the velocity potential or the acoustic pressure and where  $f$  represents the source term.

The corresponding time-dependent Green's function satisfies

$$\left( \Delta - c_0^{-2} \frac{d^2}{dt^2} \right) G(\vec{r}, t | \vec{r}_0, t_0) = -\delta(\vec{r} - \vec{r}_0) \delta(t - t_0). \quad (10.122)$$

One can obtain the integral equation satisfied by the solution  $\Psi$  of an associated boundary problem by proceeding as in section 6.2.2.1, equations (6.58) to (6.60). By identifying  $t_0$  as the variable of integration, one can write



$$\begin{aligned} \psi \frac{d^2}{dt_0^2} G - G \frac{d^2}{dt_0^2} \psi &= \frac{d}{dt_0} \left[ \psi \frac{d}{dt_0} G - G \frac{d}{dt_0} \psi \right] \\ &= \frac{\partial}{\partial t_0} \left[ \psi \frac{d}{dt_0} G - G \frac{d}{dt_0} \psi \right] \\ &\quad + \bar{U} \cdot \text{grad}_0 \left[ \psi \frac{d}{dt_0} G - G \frac{d}{dt_0} \psi \right]. \end{aligned}$$

The integral equation is therefore

$$\begin{aligned} \Psi(\vec{r}, t) &= \int_0^t dt_0 \iiint_{V_0} G(\vec{r}, t | \vec{r}_0, t_0) f(\vec{r}_0, t_0) dV_0 \\ &\quad + \int_0^t dt_0 \iiint_{V_0} \frac{\bar{U}}{c_0^2} \cdot \text{grad}_0 \left[ \psi \frac{d}{dt_0} G - G \frac{d}{dt_0} \psi \right] dV_0 \\ &\quad + \int_0^t dt_0 \iint_{S_0} [G \text{grad}_0 \psi - \psi \text{grad}_0 G] \cdot d\vec{S}_0 \\ &\quad - \frac{1}{c_0^2} \iiint_{V_0} \left[ \psi \frac{d}{dt_0} G - G \frac{d}{dt_0} \psi \right]_{t_0=0} dV_0. \end{aligned} \tag{10.123}$$

In the particular case where the flow is in the positive z-direction:

$$\begin{aligned} \iiint_{V_0} dV_0 \bar{U} \cdot \text{grad}_0 [\cdot] &= \iiint_{V_0} dV_0 \frac{\partial}{\partial z_0} (U[\cdot]) = \iiint_{V_0} dV_0 \text{div}(\bar{U}[\cdot]) \\ &= \iint_{S_0} d\vec{S}_0 \cdot (\bar{U}[\cdot]) = \iint_{S_0} dS_0 U_n[\cdot], \end{aligned}$$

with  $U = U_z$  and  $U_n = \bar{U} \cdot d\vec{S}_0 / dS_0$ .

The integral equation then becomes

$$\begin{aligned} \psi(\vec{r}, t) = & \int_0^t dt_0 \iiint_{V_0} G(\vec{r}, t | \vec{r}_0, t_0) f(\vec{r}_0, t_0) dV_0 \\ & + \int_0^t dt_0 \iint_{S_0} \left[ G \left( \frac{\partial}{\partial n_0} - \frac{U_n}{c_0^2} \frac{d}{dt_0} \right) \psi - \psi \left( \frac{\partial}{\partial n_0} - \frac{U_n}{c_0^2} \frac{d}{dt_0} \right) G \right] dS_0 \\ & - \frac{1}{c_0^2} \iiint_{V_0} \left[ \psi \frac{d}{dt_0} G - G \frac{d}{dt_0} \psi \right]_{t_0=0} dV_0. \end{aligned} \quad (10.124)$$

10.2.3.2. *Green's function for an infinite waveguide with compatible transverse geometry in presence of a uniform and constant flow in the direction of the main axis of the guide: modal theory*

When the velocity  $\vec{U}$  is strictly in the  $z$ -direction, the operator (10.121b) becomes

$$c_0^{-2} \frac{d^2}{dt^2} = c_0^{-2} \left( \frac{\partial}{\partial t} + \vec{U} \cdot \text{grad} \right)^2 = c_0^{-2} \frac{\partial^2}{\partial t^2} + 2 \frac{M}{c_0} \frac{\partial}{\partial t} \frac{\partial}{\partial z} + M^2 \frac{\partial^2}{\partial z^2}, \quad (10.125)$$

and the Green's function  $G(\vec{r}, t | \vec{r}_0, t_0)$  satisfying equation (10.122) (expressed in the stationary coordinate system, bound to the guide) is the solution to the following equation:

$$\left( \Delta - M^2 \frac{\partial^2}{\partial z^2} - 2 \frac{M}{c_0} \frac{\partial}{\partial t} \frac{\partial}{\partial z} - c_0^{-2} \frac{\partial^2}{\partial t^2} \right) G = -\delta(\vec{r} - \vec{r}_0) \delta(t - t_0). \quad (10.126)$$

In the Fourier domain, the Green's function  $G_\omega(\vec{r}, \vec{r}_0) e^{-i\omega t_0}$  satisfies the following equation:

$$\left( \Delta - M^2 \frac{\partial^2}{\partial z^2} - 2iMK \frac{\partial}{\partial z} + K^2 \right) (G_\omega e^{-i\omega t_0}) = -\delta(\vec{r} - \vec{r}_0) e^{-i\omega t_0}, \quad (10.127)$$

where  $K = \omega/c_0$  (different from the wavenumber  $k_0$  of equation (10.107), section 10.2.1) is the ratio of the angular frequency  $\omega$  measured in the stationary frame

(laboratory) to the speed of the wave expressed in the mobile system (bound to the flow), with

$$G(\vec{r}, t | \vec{r}_0, t_0) = \frac{1}{2\pi} \int_{-\infty}^{\infty} G_{\omega}(\vec{r}, \vec{r}_0) e^{i\omega(t-t_0)} d\omega. \quad (10.128)$$

To solve such a problem when the walls of the guide are perfectly reflecting, the Green's function is considered as an expansion in the basis of the eigenfunctions associated with the transverse coordinates ( $\vec{w}$ ) that satisfy Neumann's boundary conditions:

$$G_{\omega} = \sum_m f_m(z) \phi_m(\vec{w}), \quad (10.129)$$

where the eigenfunctions  $\phi_m(\vec{w})$  satisfy the following eigenvalue problem:

$$\left( \Delta_{\vec{w}} + k_m^2 \right) \phi_m(\vec{w}) = 0 \text{ in the guide,} \quad (10.130a)$$

$$\frac{\partial}{\partial n} \phi_m(\vec{w}) = 0 \text{ on the walls of the guide,} \quad (10.130b)$$

with  $\Delta_{\vec{w}} = \frac{\partial^2}{\partial x^2} + \frac{\partial^2}{\partial y^2}$  in Cartesian coordinates.

The substitution of this form of solution into the equation satisfied by the Green's function, then multiplying this equation by  $\phi_n$  and integrating over the domain corresponding to the variable  $\vec{w}$  (inner product) leads to the equation satisfied by the coefficients  $f_m(z)$ ,

$$\left[ (1 - M^2) \frac{\partial^2}{\partial z^2} - 2iMK \frac{\partial}{\partial z} + K^2 - k_m^2 \right] f_m(z) = -\phi_m(\vec{w}_0) \delta(z - z_0). \quad (10.131)$$

The functions  $f_m$  are accordingly one-dimensional Green's functions.

One can verify that the solution can be written as

$$f_m(z) = \frac{\phi_m(\bar{w}_0)}{2i\sqrt{K^2 - (1-M^2)k_m^2}} e^{-i \frac{[-MK(z-z_0)] + \sqrt{K^2 - (1-M^2)k_m^2} |z-z_0|}{1-M^2}}. \quad (10.132)$$

The argument of the exponential term is easily obtained by finding a solution of the form  $\exp[-ik_z(z-z_0)]$  to the equation

$$\left[ (1-M^2) \frac{\partial^2}{\partial z^2} - 2iMK \frac{\partial}{\partial z} + K^2 - k_m^2 \right] e^{-ik_z(z-z_0)} = 0, \quad (10.133)$$

which results in the equation of dispersion

$$k_z^2 + k_m^2 = (K - Mk_z)^2, \quad (10.134)$$

thus

$$k_z = \frac{-MK \pm \sqrt{K^2 - (1-M^2)k_m^2}}{1-M^2}. \quad (10.135)$$

It is a relatively straightforward task to verify that the Green's function  $f_m(z)$  satisfies all the required conditions by substituting its expression into the equation it must satisfy and using the following relationship (section 3.4.2.2):

$$\left[ (1-M^2) \frac{\partial^2}{\partial z^2} + \frac{K^2 - (1-M^2)k_m^2}{1-M^2} \right] \frac{e^{-i\sqrt{K^2 - (1-M^2)k_m^2} |z-z_0|}}{2i\sqrt{K^2 - (1-M^2)k_m^2}} = -\delta(z-z_0). \quad (10.136)$$

The change of the variable to  $u = z/\sqrt{1-M^2}$  and the change of function

$$\phi = \exp \left[ i \frac{KM(u-u_0)}{\sqrt{1-M^2}} \right] f,$$

leads equally to the verification of the solution.

According to whether  $z$  tends to positive or negative infinity, the Green's function represents a wave emitted in the  $z < 0$  or  $z > 0$  direction,  $\forall z$ . The following section presents the analysis of these modes of propagation based on the behavior of the constant of propagation  $k_z$  (equation (10.135)).

### 10.2.4. Phase velocity and group velocity, energy transfer – case of the rigid-walled guides with constant cross-section in uniform flow

#### 10.2.4.1. Phase velocity and group velocity

The phase velocity  $V_\varphi = \omega / k_z$ , used in its non-dimensional form  $M_\varphi = V_\varphi / c_0$ , represents the speed at which the planes of constant phase “ $\varphi_0$ ” (defined by  $\varphi_0 = \omega t - k_z z$ ) travel,

$$\frac{1}{c_0} V_\varphi = \frac{1}{c_0} \frac{\omega}{k_z} = \frac{K}{k_z} \equiv M_\varphi. \quad (10.137)$$

In the case of a dispersive wave ( $k_z$  is then a function of  $\omega$ ), the group velocity  $V_g \equiv \partial\omega / \partial k_z = c_0 \partial K / \partial k_z$  represents the speed of propagation of the energy (at least in the rigid-walled guides). The group velocity of a group of waves is that of the envelope.

The differential of the equation of dispersion (10.134)  $2k_z dk_z = 2(K - Mk_z)(dk_z - Mdk_z)$  leads to the non-dimensional group velocity

$$M_g = \frac{1}{c_0} V_g = \frac{\partial K}{\partial k_z} = M + \frac{k_z}{K - Mk_z}. \quad (10.138)$$

This expression can be modified taking into consideration equation (10.110)

$$\begin{aligned} \bar{k}_0 &= \bar{k}'_0 \text{ or } k_0^2 = k_0'^2, \\ \text{thus, } k_z^2 + k_m^2 &= k_z'^2 + k_m^2 \text{ and, consequently, } k_z = k_z', \end{aligned} \quad (10.139)$$

and the dispersion equation (10.134)

$$(K - Mk_z)^2 = k_z^2 + k_m^2 = k_0^2,$$

leading to

$$M_g = M + \frac{k_z}{k_0} = M + \frac{k'_z}{k'_0} = M + \frac{\partial k'_0}{\partial k'_z} = M + \frac{1}{c_0} \frac{\partial \omega'}{\partial k'_z}, \quad (10.140)$$

$$\text{or } M_g = M + M'_g \text{ with } M'_g = \frac{1}{c_0} \frac{\partial \omega'}{\partial k'_z}.$$

The group velocity in the absolute coordinate system ( $M_g$ ) is the sum of the velocity ( $M$ ) and the group velocity in the relative coordinate system ( $M'_g$ ). This is the classic law of addition of velocities.

#### 10.2.4.2. The energy flow

The equation of conservation of the energy can be written, by generalization of the discussion of section 1.4.4 and with  $U \neq 0$ , as

$$\frac{\partial}{\partial t} \left( \frac{1}{2} \rho_0 v^2 + \frac{p^2}{2\rho_0 c_0^2} \right) + \text{div} \left[ \left( \frac{1}{2} \rho_0 v^2 + \frac{p^2}{2\rho_0 c_0^2} \right) \bar{U} + p \bar{v} \right] = 0, \quad (10.141)$$

$$\text{or } \frac{\partial W}{\partial t} + \text{div} [W \bar{U} + p \bar{v}] = 0,$$

$$\text{or } \frac{\partial W}{\partial t} + \text{div} \bar{I} = 0, \quad (10.142)$$

where

$$W = \frac{1}{2} \rho_0 v^2 + \frac{p^2}{2\rho_0 c_0^2} \text{ is the total energy density,} \quad (10.143)$$

with

$$\frac{1}{2} \rho_0 v^2 \text{ is the kinetic energy density, and} \quad (10.144)$$

$$\frac{1}{2\rho_0 c_0^2} p^2 \text{ is the potential energy density,} \quad (10.145)$$

and where

$$\bar{I} = W \bar{U} + p \bar{v} \text{ is the total energy flow density,} \quad (10.146)$$

where  $W\bar{U}$  denotes the total energy density convected by the flow at velocity  $\bar{U}$  and  $p\bar{v}$  the energy flow of the wave.

The speed of propagation of the energy, denoted  $\bar{V}_e$ , is defined as equal to the velocity at which the energy flow passes through a cross-section of the guide. It is equal to

$$\bar{V}_e = \frac{\overline{\langle \bar{I} \rangle}}{\langle W \rangle}, \tag{10.147}$$

which is the ratio of the time average  $\overline{(\cdot)}$  and spatial mean  $\langle \cdot \rangle$  over the cross-sectional area of the energy flow to the energy density. It is, consequently, parallel to the z-axis. Thus, according to (10.146),

$$V_e = U + \frac{\overline{\langle p v_z \rangle}}{\langle W \rangle}. \tag{10.148}$$

For a harmonic wave of the form

$$p(\vec{r}, t) = P_m(k_m \vec{w}) e^{i(\omega t - k_z z)}, \tag{10.149}$$

where  $k_z$  depends on the quantum number m, Euler's equation,

$$\rho_0 \left( \frac{\partial}{\partial t} + U \frac{\partial}{\partial z} \right) \bar{v} + \text{grad } p = \vec{0}, \tag{10.150}$$

gives

$$\bar{v} = \frac{i}{\rho_0 c_0 (K - M k_z)} \text{grad } p,$$

where  $K = \omega / c_0$  and  $M = U / c_0$ , leading to

$$\overline{\langle p v_z \rangle} = \frac{1}{4} \langle p v_z^* + p^* v_z \rangle = \frac{k_z}{2 \rho_0 c_0 (K - M k_z)} \langle |p|^2 \rangle.$$

Moreover, the mean energy density

$$\overline{\langle W \rangle} = \overline{\left\langle \frac{1}{2} \rho_0 v_{\bar{w}}^2 \right\rangle} + \overline{\left\langle \frac{1}{2} \rho_0 v_z^2 \right\rangle} + \overline{\left\langle \frac{p^2}{2 \rho_0 c_0^2} \right\rangle},$$

where the index  $\bar{w}$  relates the quantity considered to its transverse components other than  $z$ , is of the form

$$\overline{\langle W \rangle} = \frac{1}{4 \rho_0 c_0^2} \left[ \frac{\overline{\langle \text{grad}_{\bar{w}} p \cdot \text{grad}_{\bar{w}} p^* \rangle}}{(K - M k_z)^2} + \frac{k_z^2}{(K - M k_z)^2} \overline{\langle |p|^2 \rangle} + \overline{\langle |p|^2 \rangle} \right].$$

Since

$$\begin{aligned} \overline{\langle \text{grad}_{\bar{w}} p \cdot \text{grad}_{\bar{w}} p^* \rangle} &= \overline{\langle \text{div}_{\bar{w}} (p^* \text{grad}_{\bar{w}} p) \rangle} - \overline{\langle p^* \Delta_{\bar{w}} p \rangle}, \\ &= -i \rho_0 c_0 (K - M k_z) \overline{\langle \text{div}_{\bar{w}} (p^* \bar{v}_{\bar{w}}) \rangle} + k_m^2 \overline{\langle |p|^2 \rangle}, \\ &= k_m^2 \overline{\langle |p|^2 \rangle} \end{aligned}$$

(the normal component  $\bar{v}_{\bar{w}}$  on the wall is null), and if one takes into account the equation of dispersion

$$k_m^2 + k_z^2 = (K - M k_z)^2,$$

the mean energy density can finally be written as

$$\overline{\langle W \rangle} = \frac{\overline{\langle |p|^2 \rangle}}{4 \rho_0 c_0^2} \left[ 1 + \frac{k_m^2 + k_z^2}{(K - M k_z)^2} \right] = \frac{\overline{\langle |p|^2 \rangle}}{2 \rho_0 c_0^2}. \quad (10.151)$$

The substitution of equations (10.150) and (10.151) into the expression (10.148) of the speed of propagation of the energy gives

$$V_e = U + \frac{\overline{\langle p v_z \rangle}}{\overline{\langle W \rangle}} = U + c_0 \frac{k_z}{K - M k_z},$$

or, finally,

$$M_e = M + \frac{k_z}{K - M k_z} = M_g. \quad (10.152)$$



The speed of propagation of the energy, expressed in the absolute (stationary) coordinate system or in the moving system, coincides with the group velocity. This result is valid for any type of guide with constant cross-sections with rigid walls and in the presence of a uniform flow.

### 10.2.5. Equation of dispersion and propagation modes: case of the rigid-walled guides with constant cross-section in uniform flow

The equation of dispersion (10.135) leads to the expression of the constant of propagation about the z-axis of the guide

$$k_z^\pm = \frac{-KM \pm \sqrt{K^2 - (1-M^2)k_m^2}}{1-M^2}. \quad (10.153)$$

The study of the various forms that this equation can take, and the interpretations of the phenomena it describes regarding the propagation about the z-axis, is presented in this section in different situations depending on the flow speed  $U$  with respect to the adiabatic speed of sound  $c_0$ .

#### 10.2.5.1. Without any flow ( $M = 0$ )

The discussions are, in this case, those in Chapters 4 and 5. Three cases are to be observed.

- i)  $K < k_m$  and  $k_z$  is a pure imaginary:
    - if  $(-ik_z) > 0$ , the amplitude of the mode increases, which does not make physical sense in unlimited media,
    - if  $(-ik_z) < 0$ , the modes are evanescent.
  - ii)  $K > k_m$  and  $k_z$  is real, then the modes are propagative and:
    - if  $k_z > 0$ , they are called “downstream propagative” in the positive z-direction ( $V_g > 0, V_\varphi > 0$ ),
    - if  $k_z < 0$ , they are called “upstream propagative” in the negative z-direction ( $V_g < 0, V_\varphi < 0$ ).
  - iii)  $K = k_m$ ,  $\omega = \omega_m$ , it is the cut-off frequency ( $V_g = 0, V_\varphi \rightarrow \infty$ ).
- The guide behaves as a high-frequency filter for the eigenvalue  $k_m$  being considered.

10.2.5.2. *With a subsonic flow ( $M < 1$ )*

i)  $K \geq k_m \sqrt{1-M^2}$  and  $k_z^\pm$  is a real number, the modes are propagative and  
 – for  $k_z^+$ ,

– if  $K \geq k_m$ ,  $k_z^+ \geq 0$ ,  $M_g > 0$ ,  $M_\phi > 0$ , the mode is downstream propagative (the phase planes and energy propagate in the same direction as the flow),

– if  $\sqrt{1-M^2} k_m \leq K \leq k_m$ ,  $\left[ \frac{-KM}{1-M^2} \right] \leq k_z^+ \leq 0$ ,  $M_g \geq 0$ ,  $M_\phi \leq 0$ , the mode

is called “inverse upstream mode”. Even though the energy is propagating in the same direction as the flow ( $M_g > 0$ ), the phase planes travel in the inverse direction ( $M_\phi < 0$ );

– for  $k_z^-$ ,

– then  $k_z^- < -\frac{KM}{1-M^2}$ ,  $M_g, M_\phi < 0$ , the mode is upstream propagative.

ii)  $K < k_m \sqrt{1-M^2}$ , the wave is attenuated since the wavenumber, when the exponentially increasing solution is not considered, is

$$k_z = \frac{-KM}{1-M^2} + i \frac{\sqrt{(1-M^2)k_m^2 - K^2}}{1-M^2}.$$

10.2.5.3. *With a sonic flow ( $M = 1$ )*

The dispersion equation must be written in the same form as in equation (10.134)

$$2Kk_z - (K^2 - k_m^2) = 0,$$

which leads to

$$k_z = \frac{K^2 - k_m^2}{2K}. \quad (10.154)$$

The group velocity  $V_g$  is positive ( $M_g > 0$ ) for any given value of  $k_z$ , consequently,

– if  $k_z \geq 0$  and  $M_\phi \geq 0$ , the mode is downstream propagative,

– if  $k_z \leq 0$  and  $M_\phi \leq 0$ , the mode is inverse upstream propagative.

The relationship  $K = k_m \sqrt{1-M^2}$  shows that the cut-off frequency tends to zero (see section 10.2.5.3 above).

10.2.5.4. *With a supersonic flow (M > 1)*

The equation of dispersion in this case yields

$$k_z^\pm = \frac{-KM \pm \sqrt{K^2 + (M^2 - 1)k_m^2}}{1 - M^2}, \tag{10.155}$$

where  $(M^2 - 1)$  is strictly positive.

The notion of cut-off frequency disappears in this case since  $k_z$  is always real. The group velocity is always positive as well ( $M_g > 0$ ). Thus

- if  $k_z \geq 0$  and  $M_\varphi \geq 0$ , the mode is downstream propagative,
- if  $k_z \leq 0$  and  $M_\varphi \leq 0$ , the mode is inverse upstream propagative.

An acoustic wave cannot propagate in the direction opposite to a sonic or supersonic flow.

**10.2.6. Reflection and refraction at the interface between two media in relative motion (at subsonic velocity)**

The object of this paragraph is to study the transmission of a plane wave through an interface ( $yz$ -plane) between two semi-infinite media in relative motion. The respective velocities  $V_1$  and  $V_2$  of those media are strictly in the same direction of the  $Oy$  axis (Figure 10.7).

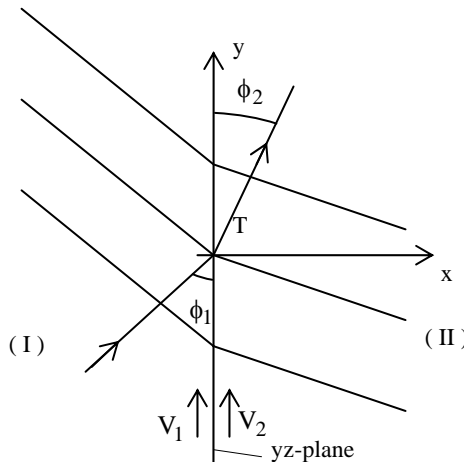

**Figure 10.7.** *Interface between two media in relative motion and plane wave*

The incident plane wave (region I) is propagating in the direction identified by the angle  $\phi_1$  with respect to the  $\vec{Oy}$  axis. The sound is partially transmitted into the region (II) in a direction of propagation  $\phi_2$ . To calculate the angle  $\phi_2$  with respect to the angle  $\phi_1$ , one needs to write that the spatial evolution of the sound field at the interface must be the same in both media, in other words write the equality of the phases at the interface, as one would in stationary medium.

The discussion here is limited to the identification of the conditions of total reflection at the interface and to the zones of shadow. This study is based on the equality between the velocity at the point T (the interface) on the phase plane (1) and the velocity at the same point on the phase plane (2). This condition is necessary to verify the equality of the phases of both waves at the interface:

$$\frac{c_1}{\cos \phi_1} + V_1 = \frac{c_2}{\cos \phi_2} + V_2. \quad (10.156)$$

If the discussion is limited to the cases where both media have the same index ( $c_1 = c_2 = c_0$ ), and focuses on the effect of the relative velocity of the second medium with respect to the first one ( $\Delta V = V_2 - V_1$ ), equation (10.156) becomes

$$\frac{1}{\cos \phi_1} - \frac{1}{\cos \phi_2} = \frac{\Delta V}{c_0}. \quad (10.157)$$

Two cases can be observed according to the sign of  $\Delta V$ .

i)  $\Delta V > 0$

Then  $\phi_2 \leq \phi_1$ . Total reflection occurs for  $\phi_1$  inferior to a critical angle  $\phi_{1c}$  such that  $\phi_2 = 0$

$$\cos \phi_{1c} = \frac{1}{1 + \Delta V / c_0}. \quad (10.158)$$

Moreover, when  $\phi_1$  takes its maximum value  $\phi_{1\max} = \pi$ ,  $\phi_2$  takes also its maximum value so that

$$\cos \phi_{2\max} = -\frac{1}{1 + \Delta V / c_0}. \quad (10.159)$$

The region where  $\phi_2 > \phi_{2\max}$  is not accessible to plane waves coming from the region (I) (Figure 10.8).

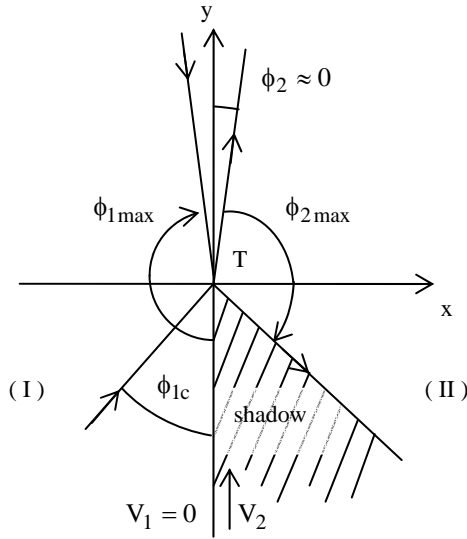

Figure 10.8. Total reflection and critical angle

ii)  $\Delta V < 0$

Then  $\phi_2 \geq \phi_1$ . The minimum value of  $\phi_2$  is obtained when  $\phi_1 = 0$

$$\cos \phi_{2\min} = \frac{1}{1 + |\Delta V|/c_0} \quad (10.160)$$

The region where  $\phi_2 < \phi_{2\min}$  is a dark zone. The maximum value of  $\phi_2$  is  $\pi$  and is obtained for  $\phi_1 = \phi_{1c}$  so that

$$\cos \phi_{1c} = -\frac{1}{1 + |\Delta V|/c_0} \quad (10.161)$$

When  $\phi_1 > \phi_{1c}$ , the reflection is total (Figure 10.9).

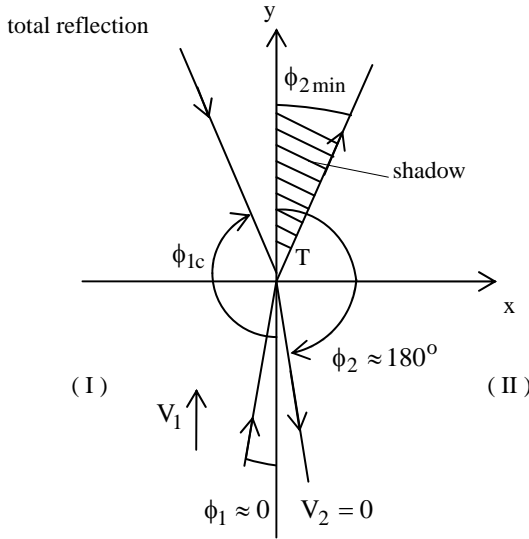

Figure 10.9. Total reflection and critical angle

Note: the reflection and transmission coefficients for a plane sinusoidal wave are obtained by writing the equations of continuity of the acoustic pressure and particle displacement at the interface. Also, the specific admittance of a wall (1.69)

$$\frac{\beta}{\rho_0 c_0} = \frac{i\omega \xi}{p},$$

must, in presence of a flow, be obtained by writing the continuity of the normal particle displacements  $\xi$  rather than the particle velocity at the interface material/fluid. Thus

$$\begin{aligned} \frac{1}{i\omega} \frac{\beta}{\rho_0 c_0} p &= \xi = \frac{1}{c_0} \left[ \frac{i}{c_0 (K - M k_z)} \right]^2 \frac{\partial p}{\partial n}, \\ &= \frac{1}{\rho_0} \frac{1}{\omega^2 (1 - M k_z / K)^2} \frac{\partial p}{\partial n}, \end{aligned}$$

and consequently

$$\frac{\partial p}{\partial n} + iK\beta(1 - M k_z / K)^2 p = 0.$$

### 10.3. Introduction to aero-acoustics

#### 10.3.1. Introduction

Aero-acoustics distinguishes itself from the other domains of acoustics by dealing with the problems of propagation in flows, of sound radiation by turbulent flows or by interaction between flows and solid bodies, and finally with the problems of sound propagation in stationary or non-stationary flows.

These problems are investigated in gases or liquids. The fluid can be either mono-phase or multiphase, chemical reactions can occur, the solids can be elastic and in motion, etc. There are numerous applications to aero-acoustics: propagation in the atmosphere, noise radiation and transmission in jet engines, aerodynamic noise transmission in rotating machines, wind turbines and fan noise, etc.

A complete treatment, necessarily numerical, of the Navier-Stokes equations in compressible and non-stationary fluids, in turbulent flows, would provide useful information concerning the acoustic fields radiated. However, even with the increased power of computers, this remains a very complex approach especially since it requires calculations of acoustic energies, the orders of magnitude of which are a millionth of the order of magnitude of the system's mechanical energy, and since the timescale and length associated with the displacement fields involved are far too great.

The range of aero-acoustic studies is very vast. The brief discussion in this section is therefore limited to and dedicated to the theory of aerodynamic sound radiation and particularly to J.M. Lighthill's theory (1952) completed by N. Curle in 1955. This theory highlights the quadrupolar property of sound sources induced by turbulence, takes into account the presence of rigid walls in the domain of propagation, and identifies the parameters that influence the propagation of the considered acoustic fields.

This introduction, far from being exhaustive, is preceded by a reminder of the linear equations of motion (which do not intervene in the aero-acoustic equations as such) in order to collect the various terms representing the two fundamental types of sources introduced in the equations of propagation.

#### 10.3.2. Reminder about linear equations of motion and fundamental sources

There are five linear equations governing the acoustic quantities  $\rho'$ ,  $\vec{v}$ ,  $p$ ,  $s$  and  $\tau$ , among which one is a vector equation (Chapter 2, equations (2.32), (2.33), (2.44), (2.4) and (2.5)). They are

– the Navier-Stokes equation

$$\rho_0 \partial_t \bar{\mathbf{v}} + \text{grad } p - \rho_0 \bar{\mathbf{F}} = \left( \eta + \frac{4}{3} \mu \right) \text{grad } \text{div } \bar{\mathbf{v}} - \mu \text{curl } \text{curl } \bar{\mathbf{v}}, \quad (10.162)$$

where  $\bar{\mathbf{F}}$  denotes the force exerted per unit of mass of the fluid by the source;

– the mass conservation law

$$\partial_t \rho' + \rho_0 \text{div } \bar{\mathbf{v}} = \rho_0 q, \quad (10.163)$$

where  $q$  denotes the volume of fluid entering the system per unit of volume and per unit of time resulting from the source;

– the equation of heat conduction

$$\rho_0 T \partial_t s = \lambda \Delta \tau + h, \quad (10.164)$$

where  $h$  denotes the calorific energy per unit of mass and per unit of time;

– the equations expressing the entropy and pressure (for example) as variables of state

$$s = \frac{C_p}{T} \left( \tau - \frac{\gamma - 1}{\hat{\beta} \gamma} p \right), \quad (10.165)$$

$$p = \frac{\rho'}{\rho_0 \chi_T} + \hat{\beta} \tau, \quad (10.166)$$

where, for a perfect gas,

$$\alpha = \hat{\beta} \chi_T = 1/T_0, \quad \hat{\beta} = P_0/T_0, \quad \chi_T = 1/P_0, \quad \rho_0 c_0^2 = \gamma P_0 = \gamma / \chi_T.$$

The elimination of the entropy variation  $s$  by using equations (10.164) and (10.165) followed by the elimination of the temperature variation  $\tau$  by using equation (10.16) leads to an equation which, combined with the equation resulting from the elimination of  $\bar{\mathbf{v}}$  using equations (10.162) and (10.163), leads to the elimination of  $\rho'$ . The resulting equation of propagation is

$$\left[ c_0^{-2} \partial_{tt}^2 - \Delta - c_0^{-2} v \Delta \partial_t \right] p = \rho_0 \left[ \partial_t q + \frac{\alpha}{C_p} \partial_t h - \text{div } \bar{\mathbf{F}} \right], \quad (10.167)$$



$$\text{with } v = \frac{1}{\rho_0} \left[ \eta + \frac{4}{3}\mu + (\gamma - 1) \frac{\lambda}{C_p} \right].$$

The source factors in the right-hand side can be separated into two categories: one involving the spatial partial derivatives of first order ( $\text{div } \vec{F}$ ) and, that is, by virtue of the linearity of these equations, responsible for an acoustic field presenting also first spatial derivatives and consequently a dipolar characteristic, and the other, the source terms that do not involve any spatial derivative and that accordingly are responsible for the acoustic fields with monopolar characteristics (factors  $\partial_t q$  and  $\partial_t h$ ).

The vibrations of solids, such as oscillating surfaces, and the impact of flows or of acoustic wave on rigid obstacles are examples of sources with dipolar characteristics (see Chapter 5). The “impulse punctual flow”, thermally or mechanically induced, presents monopolar characteristics.

The sound field induced by turbulent flows presents quadrupolar characteristics. J.M. Lighthill’s interpretation (in 1952) of this phenomenon is briefly presented in the following sections.

### 10.3.3. Lighthill’s equation

#### 10.3.3.1. Derivation of the equation

Frequently, in non-stationary flows, the areas of turbulence are relatively localized and induce variations of pressure that tend to “balance” the variations of velocity of the turbulent flow and are the origin of sound radiation. The following analysis is correct only in the coordinate system in motion, with a velocity equal to the convection velocity of the fluid.

The following derivation of Lighthill’s equation, adapted to treat the problem of radiation from small turbulent domains, gives, when taken outside these domains, the classic equation of propagation in homogeneous media:

$$c_0^{-2} \partial_{tt}^2 \rho' - \Delta \rho' = 0 \quad \text{with } \rho' = p / c_0^2. \quad (10.168)$$

Lighthill’s equation is derived from the equations of continuity in compressible media (Chapter 3) of continuity of the mass

$$\partial_t \rho + \partial_{x_j} (\rho v_j) = 0, \quad (10.169)$$

of Navier-Stokes (equations (2.25), (2.27), (2.28))

$$\partial_t(\rho \bar{v}) + \partial_{x_j}(\rho \bar{v} v_j) = \partial_{x_j} \sigma_{ij}, \quad (10.170)$$

$$\text{with } \sigma_{ij} = -p \delta_{ij} + \tau_{ij}$$

where  $\tau_{ij}$  denotes the tensor of viscous stresses and where  $p$  and  $\bar{v}$  represent the total pressures and velocities (flow and acoustic) respectively.

The application of the operator  $\partial_t$  to equation (1.169), the divergence operator to equation (10.170), and taking the difference between those two results, gives

$$\partial_{tt}^2 \rho' = \partial_{x_i x_j}^2 (\rho v_i v_j - \sigma_{ij}), \quad (10.171)$$

$$\text{where } \partial_{tt}^2 \rho' = \partial_{tt}^2 (\rho - \rho_0) = \partial_{tt}^2 \rho.$$

Then, the subtraction of the quantity  $c_0^2 \Delta \rho' = c_0^2 \partial_{x_i x_j}^2 \rho' \delta_{ij}$  (by definition of the Laplacian) on both sides of equation (10.171) leads to Lighthill's equation

$$\partial_{tt}^2 \rho' - c_0^2 \Delta \rho' = \partial_{x_i x_j}^2 T_{ij}, \quad (10.172a)$$

$$\text{where } T_{ij} = \rho v_i v_j - \tau_{ij} + (p - c_0^2 \rho') \delta_{ij} \text{ is Lighthill's tensor.} \quad (10.172b)$$

### 10.3.3.2. *Approximated expression of $T_{ij}$*

The considered flow is assumed highly localized in space. Studies on turbulence have shown that, in practice, the term  $(v_i v_j)$  is predominant in the process of aerodynamic sound radiation. It is indeed more important than the tensor  $T_{ij}$  (which introduces the viscous phenomena) and the term  $(p - c_0^2 \rho')$  (which, at the limit of the adiabaticity, is null). Consequently, in these common situations, one can assume the following approximation within the flow:

$$\tau_{ij} \approx \rho v_i v_j \approx \rho_0 v_i v_j. \quad (10.173)$$

Finally, since only a small proportion of the energy of the flow is converted into sound energy, the factor  $\rho_0 v_i v_j$  can be estimated by ignoring the contribution of the local variations in the velocity  $\bar{v}$  and only considering the turbulent motion. Thus, from the measurement or estimation of the mean turbulent velocity, the tensor  $\tau_{ij}$  is completely known.

The right-hand side term of Lighthill’s equation can now be considered as a known source term. The problem governing the acoustic sound field radiation from a domain with a turbulent flow in a uniform medium can be simplified outside the flow to the classic problem of sound radiation from a known source.

10.3.3.3. Discussion

Even if the approximation (equation (10.173)) of Lighthill’s tensor is not adopted, the propagation being governed away from the sources by the equation

$$(\partial_{tt}^2 - c_0^2 \Delta) \rho' = 0, \tag{10.174}$$

the right-hand side term of Lighthill’s equation can be considered as a quadrupolar distribution of sources generating an acoustic wave in an ideal fluid at rest. This interpretation implies that Lighthill’s tensor is negligible outside a small area of space in order to ignore the phenomena of refraction and diffusion on the heterogeneities of the flow.

Lighthill’s equation is then written in the same form as the equation of propagation of an acoustic field in a constant medium at rest generated by a quadrupolar source  $\partial_{x_i x_j}^2 T_{ij}$  localized in the area where the turbulence occurs. This equation shows the analogy between the variations of density due to the flow and those due to the radiation from a quadrupolar source. This analogy comes in useful when one needs to solve systems of non-linear equations governing the acoustic radiation from turbulent flows.

However, this approach is often limited to qualitative observations on the amplitude of the acoustic field and the parameters influencing it. Nevertheless, this theory remains particularly useful in the area it was originally developed for – jet engine noise.

**10.3.4. Solutions to Lighthill’s equation in media limited by rigid obstacles: Curle’s solution**

If it is assumed that the initial transient phase is negligible, the solution to Lighthill’s equation is then given by (section 6.2.2)

$$\rho'(\vec{r}, t) = \int_0^t dt_0 \left( \frac{1}{c_0^2} \iiint_{V_0} G(\vec{r}, t | \vec{r}_0, t_0) \partial_{x_i x_j}^2 T_{ij}(\vec{r}_0, t_0) dV_0 + \iint_{S_0} d\vec{S}_0 \cdot [G(\vec{r}, t | \vec{r}_0, t_0) \text{grad}_0 \rho'(\vec{r}_0, t_0) - \rho'(\vec{r}_0, t_0) \text{grad}_0 G(\vec{r}, t | \vec{r}_0, t_0)] \right), \tag{10.175}$$

where  $V_0$  denotes the volume of the turbulence and  $S_0$  the surface of the obstacles.

The surface integral includes the effects due to the impact of the sound wave emitted by the quadrupolar sources on the boundaries of the domain (diffraction) and those due to the hydrodynamic flow itself, including the turbulence.

Since Lighthill's equation is in reality a wave equation in a medium at rest, the integral solutions are written in the case of null mean velocity ( $U = 0$  in the integral equations in section 10.2.3.1). Accordingly, the appropriate Green's function corresponds to a medium at rest and, in an infinite space, it is

$$G(\vec{r}, t | \vec{r}_0, t_0) = \frac{\delta\left(\frac{R}{c_0} - \tau\right)}{4\pi R}, \quad (10.176)$$

with  $\vec{R} = \vec{r} - \vec{r}_0$  and  $\tau = t - t_0$ .

The following steps aim to transform the integral equation (10.175) into a better-suited form for the interpretation of the various phenomena involved. If one first writes

$$G(\vec{r}, t | \vec{r}_0, t_0) \partial_{x_i}^2 T_{ij}(\vec{r}_0, t_0) = T_{ij} \partial_{x_i}^2 G + \partial_{x_i} \left( G \partial_{x_j} T_{ij} \right) - \partial_{x_j} \left( T_{ij} \partial_{x_i} G \right), \quad (10.177)$$

and notes that  $\partial_{x_i} G = -\partial_{x_i} G$  and that the two last terms of this equation are in the form  $\text{div}[\ ]$ , the substitution of the resulting expression into equation (10.175) leads, when the Green's function considered is given by (10.176), to

$$\begin{aligned} \rho'(\vec{r}, t) = & \frac{1}{c_0^2} \partial_{x_i x_j}^2 \iiint_{V_0} dV_0 \frac{T_{ij}(\vec{r}_0, t - |\vec{r} - \vec{r}_0|/c_0)}{4\pi |\vec{r} - \vec{r}_0|} \\ & + \frac{1}{c_0^2} \int_0^t dt_0 \iint_{S_0} dS_0 \left( G n_i^0 - \partial_{x_j} \left[ T_{ij}(\vec{r}_0, t_0) + c_0^2 \delta_{ij} \rho(\vec{r}_0, t_0) \right] \right. \\ & \left. - n_j^0 \left[ T_{ij}(\vec{r}_0, t_0) + c_0^2 \delta_{ij} \rho(\vec{r}_0, t_0) \right] \partial_{x_i} G \right), \end{aligned} \quad (10.178)$$

with  $d\vec{S}_0 \cdot \text{grad}_0 = n_i^0 \delta_{ij} \partial_{x_j}$  and  $\vec{n}^0 = d\vec{S}_0 / dS_0$ .

The first double integral can be modified by writing the equation of continuity of the impulse (10.170)

$$\partial_t (\rho v_i) = -\partial_{x_j} [\rho v_i v_j + \delta_{ij} p - \tau_{ij}] ,$$

or, according to the expression (10.172b) of  $\tau_{ij}$ ,

$$\partial_t (\rho v_i) = -\partial_{x_j} \left( T_{ij} + c_0^2 \rho' \delta_{ij} \right) . \tag{10.179}$$

The substitution the Green's function (10.176) into equation (10.179), the first double integral becomes

$$-\frac{1}{c_0^2} \iint_{S_0} dS_0 n_i^0 \frac{1}{4\pi R} \partial_t \left[ \rho \left( \bar{r}_0, t - \frac{R}{c_0} \right) v_i \left( \bar{r}_0, t - \frac{R}{c_0} \right) \right] . \tag{10.180}$$

The use of the expression (10.172b) of  $T_{ij}$  leads to the following new form of the second surface integral:

$$-\frac{1}{2} \int_0^t dt_0 \iint_{S_0} dS_0 n_j^0 [\rho v_i v_j - \tau_{ij} + p \delta_{ij}] [-\partial_{x_i} G] , \tag{10.181}$$

or, taking into account the expression (10.176) of the Green's function,

$$\frac{1}{4\pi R} \frac{1}{c_0^2} \partial_{x_i} \iint_{S_0} dS_0 n_j^0 [\rho v_i v_j - \tau_{ij} + p \delta_{ij}]_{(\bar{r}_0, t-R/c_0)} . \tag{10.182}$$

In the particular case where the obstacles  $S_0$  are assumed perfectly rigid,  $n_i^0 v_i = 0$ , the first double integral and the first term of the second one are equal to zero. By denoting  $P_i = -n_j^0 (p \delta_{ij} - \tau_{ij})$ , the solution then becomes

$$\begin{aligned} \rho'(\bar{r}, t) = & \frac{1}{4\pi c_0^2} \left( \partial_{x_i x_j}^2 \iiint_{V_0} dV_0 \frac{T_{ij}(\bar{r}_0, t - |\bar{r} - \bar{r}_0|/c_0)}{|\bar{r} - \bar{r}_0|} \right. \\ & \left. - \partial_{x_i} \iint_{S_0} dS_0 \frac{P_i(\bar{r}_0, t - |\bar{r} - \bar{r}_0|/c_0)}{|\bar{r} - \bar{r}_0|} \right) . \end{aligned} \tag{10.183}$$

This equation is called Curle's equation.

The quantity  $P_i$  denotes the force per unit of area exerted onto the fluid by the boundaries of the domain (assumed perfectly rigid) in a direction perpendicular to these surfaces.

The sound field is the sum of the field generated in an infinite space by the distribution of quadrupoles ( $T_{ij}$ ) characterized by a directivity pattern with four "lobes" and the field generated by a distribution of dipoles ( $P_i$ ) on the rigid boundary surfaces of the area.

Note: in the particular case of the far field,

$$r \gg r_0 \text{ and } R = |\vec{r} - \vec{r}_0| \gg \lambda,$$

one can adopt the following approximation:

$$\begin{aligned} \partial_{x_i} \left[ \frac{f_i(\vec{r}_0, t - |\vec{r} - \vec{r}_0|/c_0)}{|\vec{r} - \vec{r}_0|} \right] &= \frac{\partial R}{\partial x_i} \partial_R \left[ \frac{f_i(\vec{r}_0, t - |\vec{r} - \vec{r}_0|/c_0)}{|\vec{r} - \vec{r}_0|} \right], \\ &= \frac{x_i - x_i^0}{R} \left[ -\frac{f_i}{R^2} - \frac{1}{c_0} \frac{1}{R} \partial_t f_i \right], \\ &\approx \frac{x_i}{R} \left[ -\frac{1}{c_0 R} \partial_t f_i \right] \approx -\frac{1}{c_0} \frac{x_i}{r^2} \partial_t f_i. \end{aligned} \quad (10.184)$$

Finally, by denoting the total reaction force from the boundary surfaces of the domain applied to the fluid

$$F_i(t - R/c_0) = \iint_{S_0} P_i \left( \vec{r}_0, t - \frac{R}{c_0} \right) dS_0,$$

and adopting Lighthill's approximation ( $T_{ij} \approx \rho_0 V_i V_j$  where  $V_i$  denotes the components of the mean turbulence velocity), the solution is

$$\begin{aligned} \rho'_\infty(\vec{r}, t) &\approx \frac{\rho_0}{4\pi c_0^4} \frac{x_i x_j}{r^3} \partial_{tt}^2 \iiint_{V_0} V_i \left( \vec{r}_0, t - \frac{R}{c_0} \right) V_j \left( \vec{r}_0, t - \frac{R}{c_0} \right) dV_0 \\ &+ \frac{1}{4\pi c_0^3} \frac{x_i}{r^2} \partial_t F_i \left( t - \frac{R}{c_0} \right). \end{aligned} \quad (10.185)$$

### 10.3.5. Estimation of the acoustic power of quadrupolar turbulences

The turbulent flow can be represented by its characteristic length  $L$  and characteristic velocity  $V$ . The ratio  $V/L$  represents the characteristic frequency. The orders of magnitude of these quantities appear in the quadrupolar source term of Curle's equation,

$$\begin{aligned} V_i V_j &\sim V^2, \\ \iiint_{V_0} dV_0 &\sim L^3, \\ \partial_{tt}^2 &\sim (V/L)^2, \\ \frac{x_i x_j}{r^3} &\sim \frac{1}{r}, \\ \text{thus } p' &\sim \rho_0 \frac{V^4 L}{r c_0^4}. \end{aligned}$$

The total acoustic power can be obtained from the following relationship:

$$P \approx 4\pi r^2 \frac{\overline{p^2}}{\rho_0 c_0} = \frac{4\pi r^2 \overline{p'^2}}{\rho_0 c_0^3}.$$

Accordingly, the acoustic power expressed with respect to the principal characteristics of the flow increases with the turbulent flow's characteristic velocity to the power eight and is given by

$$P \approx \rho_0 \frac{L^2 V^8}{\rho_0 c_0^5}.$$

### 10.3.6. Conclusion

As general as it is, Lighthill's theory does not provide answers to all the questions of aero-acoustics. It assumes, in particular, that the area occupied by the turbulent sources is small (section 10.3.3.3). In the particular cases of turbulent regimes where this hypothesis is not justifiable, the second term of Lighthill's equation represents the effect of refraction and diffusion of the sound field by the flow heterogeneities modifying the acoustic field. To overcome these difficulties, G.M. Lilley (1958) and D.M. Philipps (1960) suggested new equations governing

the sound radiation for supersonic flows, which took into consideration the phenomena of convection and refraction due to the gradients of temperature and velocity. These equations are, in many ways, expansions of Lighthill's theory, introducing the effects due to the fluid motion in the equations of propagation.

Numerous investigations contributing to the understanding of the problems of radiation and propagation of acoustic field in turbulent flows have followed. The present discussion on aero-acoustics is simply a basic introduction to this vast literature.



*This page intentionally left blank*

## Chapter 11

# Methods in Electro-acoustics

### 11.1. Introduction

The role of an electro-acoustic system is to convert a signal in a given form (electric, acoustic, optic, magnetic, piezoelectric, magnetostrictive, etc.) into a usable signal in another form (from among the same list). For example, a classic loudspeaker converts an electric signal into an acoustic signal while a classic microphone does the inverse conversion. This conversion is, most of the time, not straightforward: in the previously cited cases, a mechanical system is at the interface between the “electrical” domain and the “acoustical” domain. An electro-acoustic system provides a “cascade” of strong couplings between successive “media” of different natures. The object of this chapter is to present some general models to deal with the typical problems related to these strongly-coupled frameworks.

This chapter, by making use of previously introduced notions, does not present new concepts, but illustrates the importance of “strong coupling”, an unavoidable notion in acoustics, and provides the reader with simple and commonly used methods to describe these phenomena.

For the sake of simplicity, the important classes of electro-acoustic systems are presented separately. The different types of conversion are presented in the first section, the linear mechanical systems with localized constants are dealt with in the third section and, finally, the acoustical systems are given in the fourth section. A few practical examples that illustrate the various types of conversion are given in the fifth and last section. Finally, fundamental notions on linear electric circuits with localized and distributed constants are set out in the Appendix which ends with a more general discussion on coupling equations.

### 11.2. The different types of conversion

The most common types of conversion are: electret, thermo-acoustic or optothermo-acoustic, magnetostrictive, plasma, resistive, electromagnetic, piezoelectric, electrodynamic and electrostatic. Detailed analyses are given for the four last conversions of this list, followed by a brief introduction to the others.

#### 11.2.1. Electromagnetic conversion

An electromagnetic system is a combination of an electric coil with  $N$  turns (powered by a voltage  $U$  and through which an electrical current  $I$  passes), a core of magnetic permeability  $\mu_a$  and cross-sectional area  $S_a$ , an acoustically-reactive plate of magnetic permeability  $\mu_p$  and surface  $S_p$  (elastically suspended from a rigid frame) and fluid-filled gap between the two extremities of the electromagnet (of permeability  $\mu_0$  and thickness  $d$ ) that gives room for the vibrations of the plate close to the magnet (Figure 11.1).

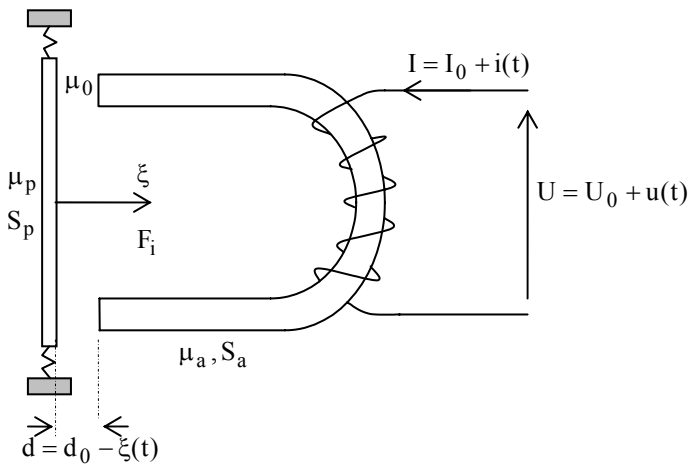

Figure 11.1. System of electromagnetic conversion

11.2.1.1. Introduction: Ampere’s theorem, magnetic Ohm’s law, Lenz’s law, plate motion

11.2.1.1.1. Ampere’s theorem

If  $\vec{H}$ ,  $\vec{B}$  and  $\Phi$  denote the magnetic field, induction field and magnetic flux in the magnetic closed circuit  $\Gamma$  respectively, Ampere’s theorem and the law of flux conversion give successively

$$NI = \int_{\Gamma} \vec{H} \cdot d\vec{\ell} = \int_{\Gamma} \frac{\vec{B}}{\mu} \cdot d\vec{\ell} = \int_{\Gamma} \frac{\Phi}{\mu S} d\ell = \Phi \int_{\Gamma} \frac{d\ell}{\mu S} = \Phi \int_{\Gamma} dR_m = \Phi R_m, \quad (11.1)$$

where the magnetic reluctance  $R_m$  is given, since  $\mu_0 \ll \mu_a, \mu_p$ , by

$$R_m = \frac{\ell_a}{\mu_a S_a} + \frac{\ell_p}{\mu_p S_p} + 2 \frac{d}{\mu_0 S} \cong \frac{2d}{\mu_0 S}, \quad (11.2)$$

$\ell_a$ ,  $\ell_p$  and  $S$  denoting respectively the length of the circuits associated with the plate, the electromagnet, and the mean cross-sectional area of the “magnetic” tube in the air gap.

These equations lead to the magnetic Ohm’s equation:

$$NI \cong \frac{2d}{\mu_0 S} \Phi. \quad (11.3)$$

#### 11.2.1.1.2. Lentz law

By definition, the coefficient of the auto-induction  $L$  of the coil is the ratio of the total flux through the coil to the electric current in the coil

$$L = \frac{N\Phi}{I} = \frac{N^2 \mu_0 S}{2d} = \frac{N^2}{R_m}. \quad (11.4)$$

#### 11.2.1.1.3. Motion of the plate

The motion of the plate is described by the law giving the difference between the position of the plate and the extremities of the electromagnet:

$$d = d_0 \left[ 1 - \frac{\xi(t)}{d_0} \right], \quad (11.5)$$

where  $d_0$  denotes the gap when the plate is not in motion and where  $\xi(t)$  represents the displacement of the plate, which is positive when the plate is moving closer to the magnet (Figure 11.1). The displacement is always assumed smaller than  $d_0$ .

The following notations, inspired by equation (11.4), are adopted:

$$L_0 = \frac{N^2 \mu_0 S}{2d_0}, \quad L = L_0 \left( 1 + \frac{\xi}{d_0} \right), \quad (11.6)$$

$$K_0 = \frac{N\Phi_0}{d_0} \quad \text{where} \quad \Phi_0 = \frac{NI_0 \mu_0 S}{2d_0}, \quad (11.7)$$

$$C_0 = \frac{\mu_0 S d_0}{2\Phi_0^2} = \frac{L_0 d_0^2}{N^2 \Phi_0^2}. \quad (11.8)$$

### 11.2.1.2. Equation of electromagnetic coupling

#### 11.2.1.2.1. The magnetic force in the armature

This force  $F_i$  represents the input or output quantity according to whether the system works as an emitter or receiver. The electromagnetic power involved is given by

$$W = \frac{1}{2} R_m(\xi) \Phi^2. \quad (11.9)$$

When considering equations (11.4) and (11.6), the magnetic force on the plate is in the form

$$F_i = - \frac{dW}{d\xi} = \frac{\Phi^2}{2} \frac{dR_m}{d\xi} = \frac{N^2 \Phi^2}{2} \frac{d(1/L)}{d\xi} = \frac{1}{2} \frac{N^2 \Phi^2}{L_0 d_0}. \quad (11.10)$$

By writing the electric current  $I$  as the superposition of a direct current  $I_0$  and an alternative current (variation)  $i(t)$  (assumed here small compared to  $I_0$ ), and using equations (11.4) and (11.6), one obtains

$$\Phi = \frac{LI}{N} = \frac{L_0 I_0}{N} \left( 1 + \frac{\xi}{d_0} \right) \left( 1 + \frac{i}{I_0} \right),$$

and the approximated form of the force  $F_i$

$$F_i = \frac{1}{2} \frac{N^2 \Phi_0^2}{L_0 d_0} + \frac{N^2 \Phi_0^2}{L_0 d_0} \left( \frac{\xi}{d_0} + \frac{i}{I_0} \right),$$

or  $F_i = F_{i0} + f_i$ , (11.11)

with

$$F_{i0} = \frac{1}{2} \frac{N^2 \Phi_0^2}{L_0 d_0} \quad \text{and} \quad f_i = \frac{N^2 \Phi_0^2}{L_0 d_0} \left( \frac{\xi}{d_0} + \frac{i}{I_0} \right). \quad (11.12)$$

The second equation (11.12) constitutes the first equation of electromagnetic coupling between the variations of mechanical and electrical quantities. Taking into account equations (11.7) and (11.8), it is often written as

$$f_i = K_0 i + \frac{1}{C_0} \xi. \quad (11.13a)$$

#### 11.2.1.2.2. Electromotive force at the terminals of the coil

This electromotive force  $U$  represents the input or output quantity according to whether the system works as an emitter or a receiver. The time-dependent component  $u(t)$  of the electromotive force  $U = U_0 + u(t)$  is given by

$$\begin{aligned} u(t) &= N \frac{d\Phi}{dt} = N \frac{1}{N} \frac{d(Li)}{dt}, \\ &= \frac{d}{dt} \left[ L_0 \left( 1 + \frac{\xi}{d_0} \right) I_0 \left( 1 + \frac{i}{I_0} \right) \right] = L_0 \frac{di}{dt} + \frac{N\Phi_0}{d_0} \frac{d\xi}{dt}. \end{aligned}$$

The second coupling equation in the time domain is therefore

$$u = L_0 \frac{di}{dt} + K_0 \frac{d\xi}{dt}. \quad (11.13b)$$

#### 11.2.1.2.3 Coupling equations: discussion

The factor  $K_0$  is called the electromechanic coupling coefficient of the electromagnetic transducer and  $(-C_0)$  is the mechanic compliance due to the “magnetic polarization” (the associated rigidity  $-C_0^{-1}$  adds to the mechanical rigidity  $C_m^{-1}$ ).

The factors  $K_0$  and  $C_0^{-1}$  only exist if the permanent polarization  $\Phi_0$  is not null (equations (11.1) and (11.8)). Consequently, the constant quantities  $U_0$ ,  $I_0$  and  $F_{i0}$  must be non-null and the system is then qualified as “active”. Moreover, the factors of first order of  $i$  and  $\xi$  ((11.13), for example) vanish if  $K_0$  and  $C_0^{-1}$  are null. In such conditions, the expansions would be introduced at the second order in the equations, and the transducer would not be considered linear anymore. Finally, the active linear transducer is called reciprocal since it works either as an emitter or as a receiver.

11.2.1.2.4. Coupling equations in the frequency domain

The coupling equations (11.13) in sinusoidal regime can be written as

$$u = j\omega L_0 i + K_0 v, \tag{11.14a}$$

$$(-f_i) = -K_0 i + \frac{1}{j\omega(-C_0)} v, \tag{11.14b}$$

where  $j = \sqrt{-1}$  and where  $v = j\omega \xi$  denotes the vibration velocity of the plate.

This system of equations can be indifferently represented by one of the equivalent electric circuits of Figure 11.2. (The conventions of notation and definitions are detailed in the Appendix to this chapter.)

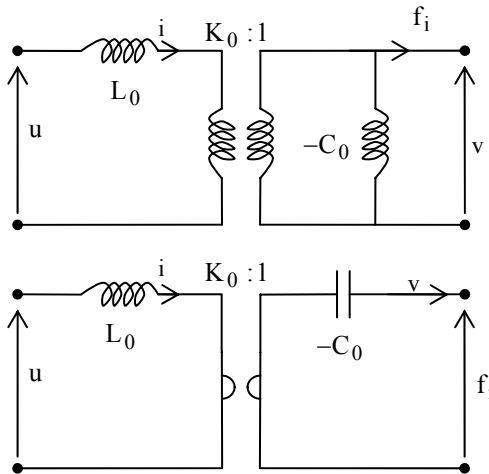

Figure 11.2. Equivalent electric circuits (coupling equations (11.14a and b))

**11.2.2. Piezoelectric conversion (example)**

A piezoelectric membrane of surface area  $A$ , thickness  $h$  and width  $b$  (Figure 11.3a), shaped as a portion of a cylinder of radius  $R$  and with a small angle of curvature  $\phi$  (Figure 11.3b) is fixed at its extremities  $B$  and  $B'$ . An electric field  $E_3(t) = u/h$  applied about the axis “3” induces a positive variation of length per unit of length  $S_1(t)$  about the axis “1” and consequently a radial displacement  $\xi = \partial_t^{-1}v$  so that

$$R\phi + S_1 R\phi = (R + \xi)\phi,$$

$$\text{or } S_1 = \frac{1}{R} \partial_t^{-1}v. \tag{11.15}$$

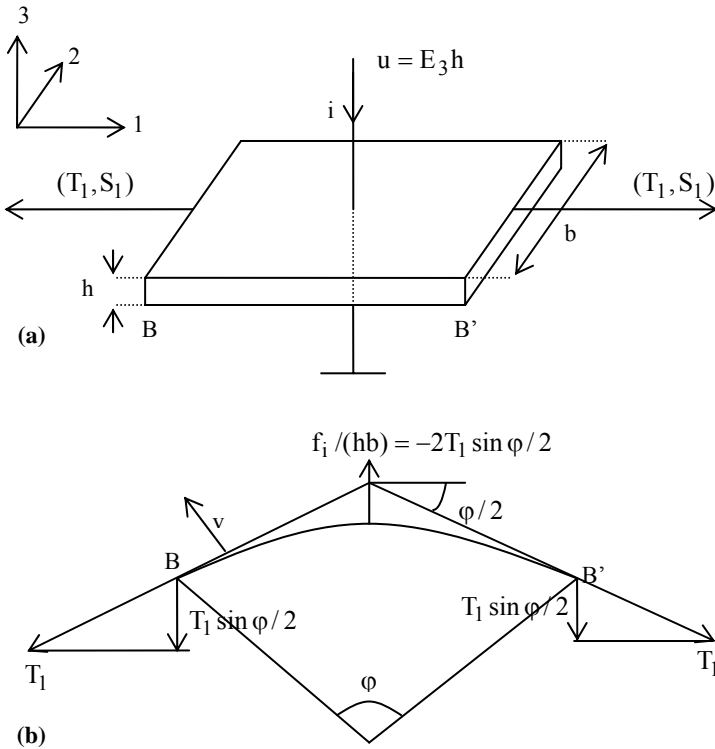

**Figure 11.3.** Piezoelectric membrane (a) plane view, (b) side view



11.2.2.1. *Introduction: electric induction and piezoelectricity*

## 11.2.2.1.1. Electric induction

The fundamental law of electrostatics applied to the plane condenser of dielectric permeability  $\varepsilon$  and bearing an electric charge  $q_3$  is written in the form

$$D_3 = \varepsilon E_3, \quad (11.16)$$

where  $D_3 = q_3 / A$  denotes the instantaneous electric induction field and where  $E_3 = u / h$  denotes the electric field associated with the variation of voltage  $u$ . The resulting variation of electric current is then

$$i = \frac{\partial q_3}{\partial t} = A \frac{\partial D_3}{\partial t}. \quad (11.17)$$

## 11.2.2.1.2. Law of piezoelectricity

If  $T_1$  denotes the tension (per unit of area) exerted on the membrane element in the direction “1”, the general laws of piezoelectricity (detailed in the following section)

$$S_\alpha = s_{\alpha\beta} T_\beta + d_{i\alpha} E_i, \quad (11.18a)$$

$$D_i = d_{i\alpha} T_\alpha + \varepsilon_{ij} E_j, \quad (11.18b)$$

(summed over  $j$ ), take here the particular forms

$$S_1 = s_{11} T_1 + d_{31} E_3, \quad (11.19a)$$

$$D_3 = d_{31} T_1 + \varepsilon_{33} E_3. \quad (11.19b)$$

11.2.2.2. *Equations of coupling*

## 11.2.2.2.1. Piezoelectric radial force

The radial force, resulting from the piezoelectric tension  $T_1$ , represents the input or output quantity according to whether the system works as an emitter or a receiver.

According to the above definitions (Figure 11.3b), the force variation is

$$f_i = -h b 2T_1 \sin(\varphi/2) \approx -h b T_1 \varphi.$$

Taking into account equations (11.19a) and (11.15) to (11.17), the above equation can be written as

$$(-f_i) = \frac{1}{C} \partial_t^{-1} v - K_0 u, \quad (11.20a)$$

$$\text{with } C = \frac{R s_{11}}{h b \varphi} \text{ and } K_0 = b \varphi \frac{d_{31}}{s_{11}}.$$

This constitutes the first equation of coupling required.

#### 11.2.2.2.2. Electric voltage at the terminals of the circuit

The potential difference represents the input or output quantity according to whether the system works as an emitter or a receiver.

Equations (11.15) to (11.17) and (11.19b) give

$$i = b R \varphi \partial_t D_3 = b R \varphi \partial_t \left[ d_{31} \left( \frac{S_1}{s_{11}} - \frac{d_{31}}{s_{11}} E_3 \right) + \varepsilon_{33} E_3 \right],$$

$$\text{or } i = K_0 v + C_0 \partial_t u, \quad (11.20b)$$

$$\text{with } C_0 = \frac{b R \varphi}{h} \varepsilon_{33} \left( 1 - \frac{d_{31}^2}{s_{11} \varepsilon_{33}} \right).$$

This constitutes the second equation of coupling.

This piezoelectric system is qualified as “passive” since no polarization voltage is required and “reciprocal since it works either as an emitter or as a receiver.

#### 11.2.2.2.3. Equations of coupling in the frequency domain

In sinusoidal regime, the coupling equations (11.20) become

$$u = \frac{1}{j\omega C_0} i - \frac{1}{j\omega C_0 / K_0} v, \quad (11.21a)$$

$$(-f_i) = \frac{-1}{j\omega C_0 / K_0} i + \frac{1}{j\omega} \left( \frac{1}{C} + \frac{K_0^2}{C_0} \right) v. \quad (11.21b)$$

The factor  $K_0$  is called the conversion factor, and the factor  $K_0/(j\omega C_0)$  the coefficient of piezoelectric coupling. This system of equations can be represented by the equivalent electric circuit in Figure 11.4. (The conventions of notations and definitions are detailed in the Appendix to this chapter.)

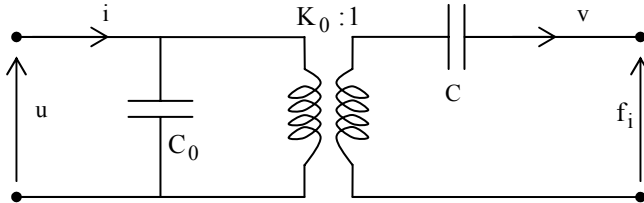

**Figure 11.4.** Equivalent electric circuit (coupling equations (11.21))

11.2.2.3. Digression on the tensor expression of piezoelectricity

In the general case of anisotropic materials, the expression of the three-dimensional piezoelectricity is in the following form (using Einstein’s convention for the summation)

$$D_i = \epsilon_{ij}E_j + e_{ijk}S_{jk} , \tag{11.22a}$$

$$T_{jk} = e'_{ijk} E_i + C_{jklm}S_{lm} , \tag{11.22b}$$

$$i, j, k, \ell, m = 1, 2, 3.$$

Since the tensor  $S_{jk}$  is symmetrical,  $S_{jk} = S_{kj}$  (see section 2.2.1, equations (2.8c) and (2.13)) and the tensor  $\epsilon_{ijk}$  is symmetrical with respect to the two first indexes, the set of nine values taken by the index couple (j,k) is reduced to a set of six values. In practice, the index couple (j,k) is replaced by a single index  $\alpha = 1 \dots 6$  and similar notations are used for the quantities in equations (11.2). Consequently

$$D_i = \epsilon_{ij}E_j + e_{i\alpha}S_{\alpha} , \tag{11.23a}$$

$$T_{\alpha} = e'_{i\alpha}E_i + C_{\alpha\beta}S_{\beta} , \tag{11.23b}$$

$$i, j = 1, 2, 3 \text{ and } \alpha, \beta = 1 \dots 6 .$$

The variation of internal energy per unit of volume of the material during the reversible transformation,

$$dU = \theta d\sigma + T_{\alpha} dS_{\alpha} + E_i dD_i ,$$

where  $\theta$  and  $\sigma$  denote the thermodynamic temperature and the entropy per unit of volume respectively, leads to the following variation of thermodynamic potential  $G = U - E_i D_i$  :

$$dG = \theta d\sigma + T_\alpha dS_\alpha - D_i dE_i ,$$

The associated Cauchy relationships become

$$\left. \frac{\partial D_i}{\partial S_\alpha} \right)_{\sigma, E_i} = - \left. \frac{\partial T_\alpha}{\partial D_i} \right)_{\sigma, S_\alpha} .$$

According to equations (11.23a) and (11.23b), and with the transformations being assumed to be isentropic, the above Cauchy conditions imply that

$$e'_{i\alpha} = -e_{i\alpha} . \tag{11.24}$$

Equation (11.24) shows that the inverse piezoelectric effect is a thermodynamic consequence of the direct piezoelectric effect. Finally, the coupled equations (11.23) are

$$D_i = \epsilon_{ij} E_j + e_{i\alpha} S_\alpha , \tag{11.25a}$$

$$T_\alpha = -e_{i\alpha} E_i + C_{\alpha\beta} S_\beta . \tag{11.25b}$$

Note: the piezoelectric effect could have be expressed using the variables  $(E, T)$  rather than  $(E, S)$  . The same approach, using the thermodynamic function

$$U - E_i D_i - T_\alpha S_\alpha ,$$

leads to the following coupled equations:

$$S_\alpha = s_{\alpha\beta} T_\beta + d_{i\alpha} E_i , \tag{11.26a}$$

$$D_i = d_{i\alpha} T_\alpha + \epsilon_{ij} E_j . \tag{11.26b}$$

These equations are those used in section 11.2.2.1.2.

**11.2.3. Electrodynamic conversion**

An electric coil (called the voice-coil) of length  $\ell$  and impedance  $Z_e(\omega) = R_e(\omega) + j\omega L_e(\omega)$ , with a variation of voltage  $u(t)$  between its terminals and bearing an electric current  $i(t)$  (Figure 11.5) is rigidly attached to a moving device (of velocity  $v(t)$ ). The whole system is under the action of a permanent magnetic field  $\vec{B}$  generated by a circular magnet and resulting in an electrodynamic force  $f_i$  exerted onto the coil.

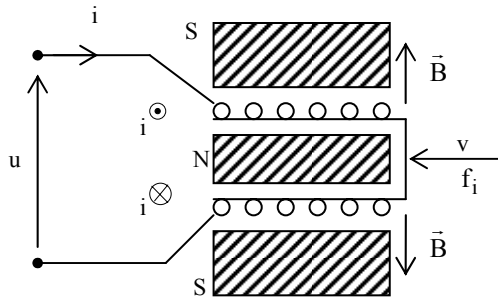

**Figure 11.5.** *Electrodynamic system*

11.2.3.1. *Introduction: Faraday and Lenz-Laplace laws*

Using the orientations given in Figure 11.5, the counter-electromotive force induced in the coil is given, according to Faraday’s law, by the mixed product  $\vec{B} \cdot (\vec{\ell} \wedge \vec{v})$ . Consequently, the electromotive force is

$$e_i = B \ell v . \tag{11.27}$$

Also, Lenz-Laplace law,  $d\vec{f}_i = i d\vec{\ell} \wedge \vec{B}$ , leads to

$$f_i = B \ell i . \tag{11.28}$$

11.2.3.2. *Coupling equations*

The coupling equations can be written in the simple forms

$$u = Z_e i + B \ell v , \tag{11.29a}$$

$$f_i = B \ell i , \tag{11.29b}$$

where the product  $B \ell$  denotes the conversion factor or the electrodynamic coupling factor.

This system of coupled equations can be represented by either of the equivalent electric circuits in Figure 11.6. The system is qualified as passive (no polarization voltage required) and reciprocal (works either as an emitter and a receiver). (The conventions of notations and definitions are detailed in the Appendix to this chapter.)

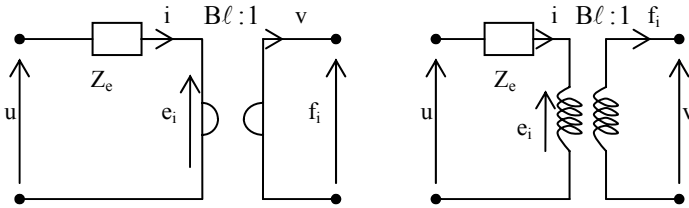

Figure 11.6. Equivalent electric circuits (coupling equations (11.29))

### 11.2.4. Electrostatic conversion

An electric capacitor of surface area  $S$  and dielectric permeability  $\epsilon$  is made of two frames (one fixed, the other not)  $d(t) = d_0 + \xi(t)$  away from each other (where  $d_0$  is a positive constant and where the sign of the displacement  $\xi$  is defined in Figure 11.7). The capacitor is powered by a potential  $U = U_0 + u(t)$  and bears an electric current  $I = I_0 + i(t)$  (sum of the direct and alternative variables). Thus

$$C = \frac{\epsilon S}{d} = \frac{\epsilon S}{d_0(1 + \xi/d_0)} = \frac{C_0}{1 + \xi/d_0}, \tag{11.30}$$

where  $C_0$  denotes here the “static” electric capacitance of the capacitor.

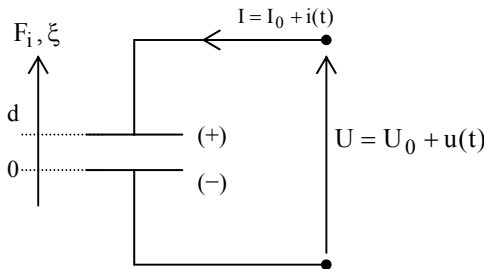

Figure 11.7. Electric capacitance with mobile armature

The relationship

$$U(t) = \frac{Q(t)}{C(t)} = \frac{Q_0 + q(t)}{C_0 / (1 + \xi/d_0)},$$

where  $Q = Q_0 + q$  represents the electric charge of the capacitor and is, at the first order of the quantity  $\xi/d_0$ ,

$$U_0 + u(t) \cong \frac{Q_0}{C_0} + \frac{q}{C_0} + \frac{U_0}{d_0} \xi,$$

leads directly to the first coupling equation

$$u(t) = \frac{1}{C_0} \partial_t^{-1} i + \frac{U_0}{d_0} \partial_t^{-1} v. \quad (11.31)$$

The function  $u(t)$  represents the input or output quantity according to whether the system works as an emitter or a receiver. The other (input or output) quantity is represented by the force  $F_i$  applied to the mobile frame. Adopting the sign convention given by Figure 11.7, the electrostatic equilibrium is written as

$$F_i = \int \frac{U}{d} C dU = \frac{1}{Cd} \int_0^Q Q' dQ' = \frac{1}{2} \frac{Q^2}{Cd} = \frac{1}{2C_0 d_0} (Q_0 + q)^2,$$

or, at the first order of the perturbations, as

$$F_{i0} + f_i(t) \cong \frac{Q_0^2}{2C_0 d_0} + \frac{U_0}{d_0} q.$$

The second coupling equation is therefore

$$f_i = \frac{U_0}{d_0} \partial_t^{-1} i. \quad (11.32)$$

The coefficient  $U_0 / (j\omega d_0)$  is called the electromechanic coupling coefficient of the electrostatic system and  $U_0 C_0 / (-d_0)$  is the conversion factor. The system requires a polarization voltage to operate linearly. It is therefore qualified as active. Moreover, it is qualified as reciprocal since it works either as an emitter or as a receiver.

In sinusoidal regime, the coupling equations become

$$u = \frac{1}{j\omega C_0} i + \frac{1}{j\omega d_0 / U_0} v, \tag{11.33a}$$

$$f_i = \frac{1}{j\omega d_0 / U_0} i. \tag{11.33b}$$

The system of coupled equations can be represented by the equivalent electric circuit of Figure 11.8. (The conventions of notations and definitions are detailed in the Appendix to this chapter.)

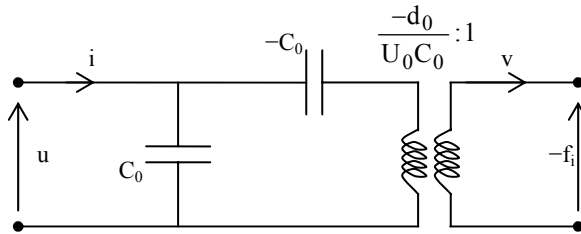

**Figure 11.8.** Equivalent electric circuit (coupling equations (11.33))

**11.2.5. Other conversion techniques**

The object of this paragraph is to briefly present the other principal conversion techniques.

The electret conversion is based on the same principle as the electrostatic conversion except that the external voltage supply is replaced by an element of the capacitor (the electret) that is permanently polarized. This element can either be the mobile electrode (membrane), the static electrode or the dielectric itself.

The thermo-acoustic and optothermo-acoustic conversions are based on the conversion of heat received from an external source into pressure variation, in a small cavity for example (section 3.5, the factor *h* in equation (3.72)). Moreover, the heat can be supplied by conversion of electromagnetic energy (light) into calorific energy (on carbon fibers for example), the electromagnetic energy coming from, for example, an electroluminescent diode or a laser diode through an optic fiber, etc. The thermo-acoustic conversion can also be achieved by maintaining a temperature gradient along a stack inside an acoustic resonator.

The magnetostrictive conversion makes use of the phenomenon of distortion of the ferromagnetic materials under the action of a magnetic field.



The plasma conversion (at high or ambient temperatures) is based on the generation of oscillations in ionized fluids at the vicinity of a highly charged electrode and under the action of a modulated electric field. The resulting oscillations generate an acoustic signal.

The resistive conversion applies the relation between electric resistance and stress, characteristic of some materials such as the carbon grains in the old-fashioned phones and more recently in the piezoresistive or magnetoresistive materials.

This list is of course not exhaustive.

### 11.3. The linear mechanical systems with localized constants

#### 11.3.1. *Fundamental elements and systems*

##### 11.3.1.1. *The mechanical elements (translational motion)*

A linear mechanical system with localized constants is made of three fundamental elements: a mass, a dissipative element, and a spring. All forces involved are time dependent (in the context of this chapter) and denoted by small letters.

According to Newton's second law ( $f_m = m dv/dt$ ), the acceleration  $dv/dt$  (algebraic value) is induced to the mass  $m$  (an element considered as dipolar) by the force  $f_m$  (also an algebraic value). The vibration velocity of the mass  $m$  is time dependent. Figure 11.9(a) gives the main axes and directions of the problem. The energy stored in the system as kinetic energy is  $m v^2 / 2$ .

The dissipative element of mechanical resistance  $r$  is a dipolar element that, under the action of a force  $f_r$  (at both extremities), induces, according to the law  $f_r(t) = r v(t)$ , a relative velocity between its extremities (Figure 11.9(b)). Such system dissipates the mechanical energy  $r v^2 / 2$  by Joule's effect.

The spring of elasticity  $C$  (stiffness  $1/C$ ) is a dipolar element that, under the action of a force  $f_c$  applied on both extremities, induces, according to the law  $f_c(t) = \xi(t)/C$ , a relative displacement  $\xi$  between its extremities (Figure 11.9(c)). The energy stored in the system as potential energy is given by  $C f_c^2 / 2$ .

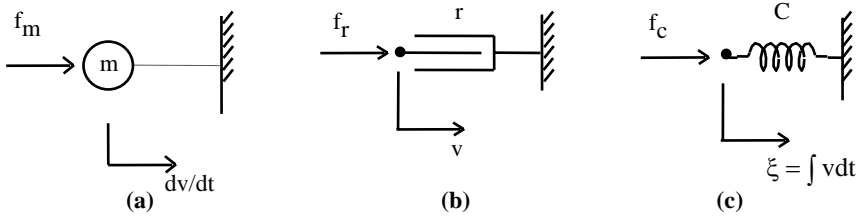
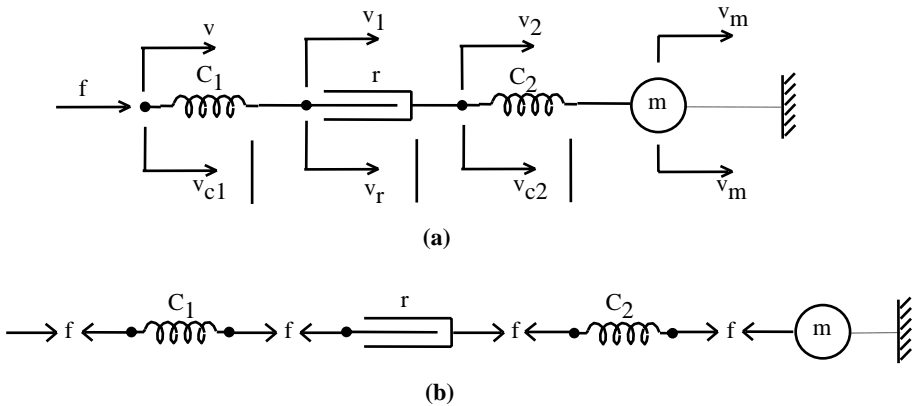

**Figure 11.9.** Fundamental elements of linear mechanical system: (a) mass; (b) dissipative element; and (c) spring. (With the exception of  $m$ ,  $r$  and  $C$ , all the quantities are algebraic values)

11.3.1.2. The mechanical systems

11.3.1.2.1. Systems where equal force is exerted on all elements

An example of such a system is presented in Figure 11.10(a). The quantities  $v$ ,  $v_1$ ,  $v_2$  and  $v_m$  are the velocities of the considered points from the point of view of an observer positioned in the reference frame and  $v_{c1}$ ,  $v_r$  and  $v_{c2}$  are the relative velocities associated with each element:  $v_{c1} = v - v_1$ ,  $v_r = v_1 - v_2$  and  $v_{c2} = v_2 - v_m$ .



**Figure 11.10.** Example of mechanical system where the same force is applied to all elements (a); and “expression” of the force (b)

Figure 11.10(b) illustrates this notion of common force. To clarify the terminology, one needs to stress the notion of algebraic value  $f$  as (for example) the force  $f$  that the spring  $C_2$  exerts on the mass  $m$  if it represents the orthogonal projection of the vectorial force  $\vec{f}$  onto the axis located on the left of the force  $f$ ,

and denotes the force that the mass exerts on the spring  $C_2$  if the same algebraic number  $f$  represents the orthogonal projection of  $\vec{f}$  unto the axis located on the right of the force  $f$ .

The elementary law of composition of velocities, corresponding to Kirchhoff's first law (the current leaving a node is equal to the sum of the currents entering where the velocity is here interpreted as a current), can be written in the form

$$\begin{aligned}
 v &= v_{c1} + v_r + v_{c2} + v_m \\
 &= C_1 \frac{df}{dt} + \frac{1}{r} f + C_2 \frac{df}{dt} + \frac{1}{m} \int f dt,
 \end{aligned}
 \tag{11.34a}$$

or, in the frequency domain,

$$v = \left( j\omega C_1 + \frac{1}{r} + j\omega C_2 + \frac{1}{j\omega m} \right) f,
 \tag{11.34b}$$

$$= \left( \sum_i Y_{Mi} \right) f = Y_M f,
 \tag{11.34c}$$

where the factors  $Y_{Mi}$  and  $Y_M$  denote the mechanical admittances.

11.3.1.2.2. System where the velocity is the same for all elements

An example of such system is given in Figure 11.11.

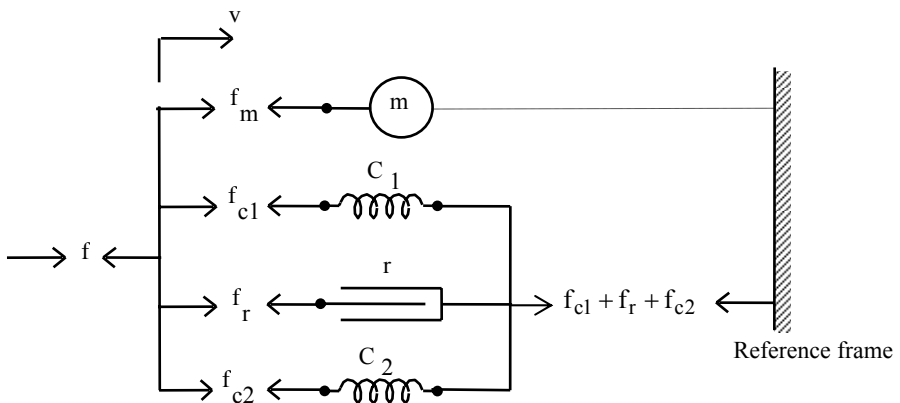

**Figure 11.11.** Example of mechanical system where  $v=d\xi/dt$  is common to all elements

According to the orientations given in Figure 11.11, the equilibrium of forces, corresponding to Kirchhoff's second law (the total of the potential differences between nodes in a closed loop is equal to the total electromotive force in that loop), can be written in the successive forms

$$f = f_{c1} + f_r + f_{c2} + f_m = m dv/dt + \frac{1}{C_1} \int v dt + \frac{1}{C_2} \int v dt + r v, \quad (11.35a)$$

or, in the frequency domain,

$$f = \left( j\omega m + \frac{1}{j\omega C_1} + \frac{1}{j\omega C_2} + r \right) v, \quad (11.35b)$$

$$= \left( \sum_i Z_{Mi} \right) v = Z_M v, \quad (11.35c)$$

where  $Z_{Mi}$  and  $Z_M$  denote the mechanical impedances.

### 11.3.1.2.3. Mechanical converters

The system considered is a lever. Notations and orientations are given in Figure 11.12.

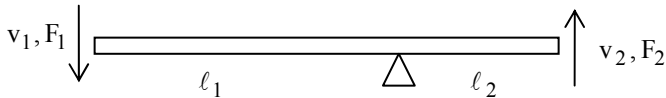
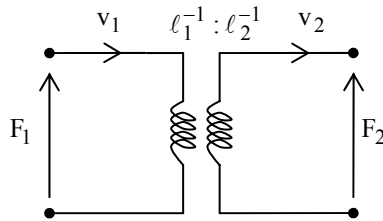

**Figure 11.12.** *Mechanical converter (lever)*

The equations governing the motion of such system (kinetic and dynamic) are

$$\frac{F_1}{F_2} = \frac{\ell_1^{-1}}{\ell_2^{-1}} \text{ and } \frac{v_1}{v_2} = \frac{\ell_2^{-1}}{\ell_1^{-1}}. \quad (11.36)$$

These laws are those of an ideal electrical converter of Figure 11.13 (see Appendix, A1).



**Figure 11.13.** *Electrical converter equivalent to the lever*

### 11.3.2. Electromechanical analogies

The methods in electro-acoustics extensively use circuit diagrams (equivalent to the mechanical and acoustical systems). Section 11.2, dealing with the conversion processes, presents the electric circuits where the electrical and mechanical quantities appear together. Accordingly, it is convenient to express the laws governing mechanical systems in the form of equivalent electric circuits (following the example in the previous section) in order to achieve a uniform and global representation of complex electro-acoustic systems (where the mechanical, acoustical and electrical components are strongly coupled). It is the object of this section to present the methods leading to those circuits, equivalent to the common electro-acoustic systems.

#### 11.3.2.1. Analogies of impedance and admittance

##### 11.3.2.1.1. Impedance analogy

The associations in an analogy of impedance are:

- to a force  $f$  is associated a voltage  $u$ ,
- to a velocity  $v$  is associated an electric current  $i$ ,
- to a displacement  $\xi$  is associated an electric charge  $q$ .

Consequently:

– to a mass  $m$  is associated a self-inductance  $L$ , leading to the equivalent mechanical laws

$$f_m = m \frac{dv}{dt} \text{ and } u_L = L \frac{di}{dt},$$

$$E_m = \frac{1}{2}mv^2 \text{ and } E_L = \frac{1}{2}Li^2,$$

– to a compliance  $C$  (m/N) is associated the capacitance  $C$  (farad), leading to the equivalent laws

$$f_c = \xi / C \text{ and } u_c = q / C ,$$

$$E_c = \frac{1}{2} C f_c^2 \text{ and } E_c = \frac{1}{2} C u_c^2 ,$$

– to a mechanical reactance  $r$  is associated the electrical resistance  $R$  , leading to:

$$f_r = r v \text{ and } u_r = R i ,$$

$$E_r = \frac{1}{2} r v^2 \text{ and } E_R = \frac{1}{2} R i^2 .$$

#### 11.3.2.1.2. Admittance analogy

The associations in an analogy of admittance are:

- to a force  $f$  is associated an electric current  $i$  ,
- to a velocity  $v$  is associated a voltage  $u$  ,
- to a displacement  $\xi$  is associated the indefinite integral of the voltage  $\int u dt$  .

Consequently,

– to a mass  $m$  is associated the electric capacitance  $C$  , leading to the equivalent laws

$$f_m = m \frac{dv}{dt} \text{ and } i_c = C \frac{du}{dt} ,$$

$$E_m = \frac{1}{2} m v^2 \text{ and } E_c = \frac{1}{2} C u^2 ,$$

– to a compliance  $C$  (m/N) is associated the self-inductance  $L$  , leading to

$$f_c = \frac{1}{C} \int v dt \text{ and } i_L = \frac{1}{L} \int u dt ,$$

$$E_c = \frac{1}{2} C f_c^2 \text{ and } E_L = \frac{1}{2} L i^2 ,$$

– to a mechanical resistance  $r$  is associated the electrical conductance  $(1/R)$  , leading to

$$f_r = r v \text{ and } i_R = (1/R) u ,$$

$$E_r = \frac{1}{2} r v^2 \quad \text{and} \quad E_R = \frac{1}{2} \left( \frac{1}{R} \right) u^2.$$

11.3.2.2. Application of the analogies to mechanical systems with localized constants

11.3.2.2.1. Mechanical systems with equal force on all elements

The derivation of the equivalent electrical diagrams is, for the sake of the example, carried out for the mechanical circuit represented in Figure 11.10. The law (11.34b) is valid for both the equivalent circuit by impedance analogy (Figure 11.14(a)) and the equivalent circuit by admittance analogy (Figure 11.14(b)).

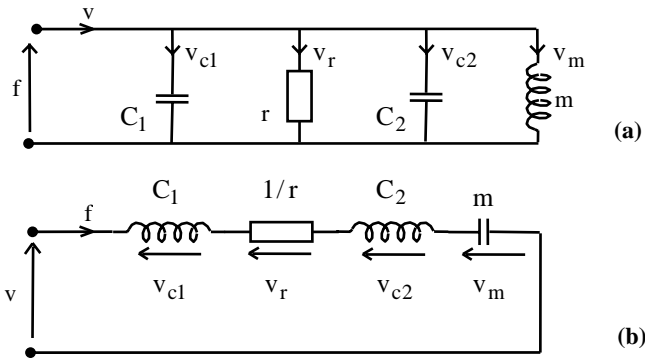
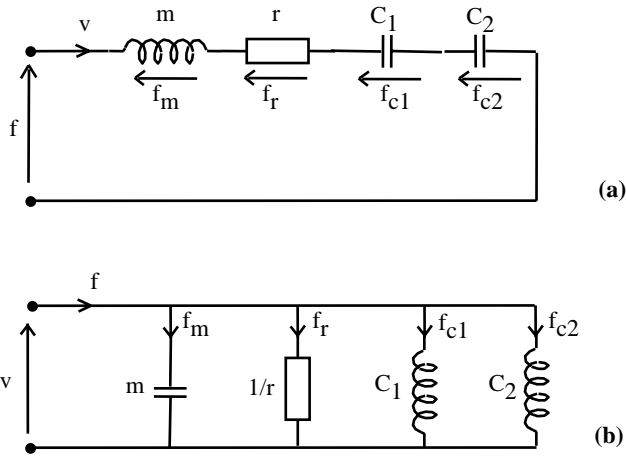

**Figure 11.14.** Equivalent electrical circuits obtained by analogy of (a) impedance type and (b) admittance type with  $v_{c1} = i\omega C_1 f$ ,  $v_r = f / r$ ,  $v_{c2} = j\omega C_2 f$  and  $v_m = f / (j\omega m)$

The admittance analogy presents two advantages over the impedance analogy: it respects the structure of the mechanical systems considered, as well as the notion of electrical potential of reference as electrical earth. Nevertheless, it is more intuitive to associate an electrical current with a mechanical velocity rather than with a force.

11.3.2.2.2. Mechanical systems with the same velocity of all elements

The mechanical system considered, as an example, is represented in Figure 11.11. The law (11.35b) is valid for both the equivalent circuit obtained by impedance analogy (Figure 11.15(a)) and the one obtained by admittance analogy (Figure 11.15(b)).

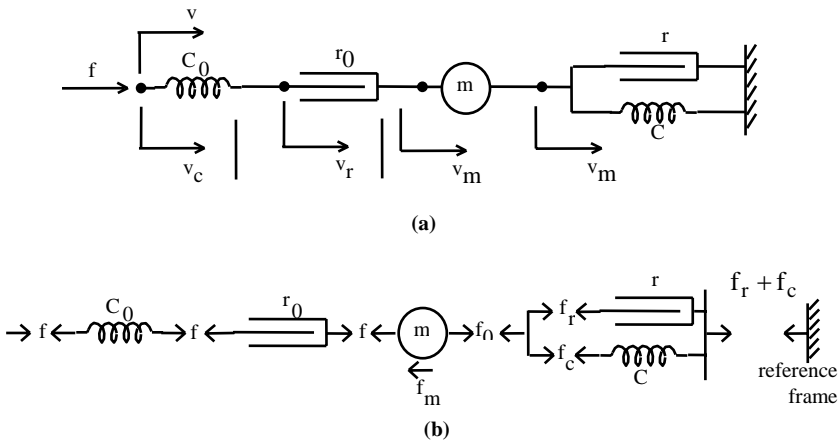

**Figure 11.15.** Equivalent electrical circuits obtained by analogy of (a) impedance and (b) admittance with  $f_m = j\omega m v$ ,  $f_r = r v$ ,  $f_{c1} = v/(j\omega C_1)$  and  $f_{c2} = v/(j\omega C_2)$

Here again, the admittance analogy respects the structure of the mechanical system (where the mass  $m$  is suitably referenced with respect to the electrical ground).

### 11.3.2.3. Adapted mechanical diagrams

Once again, this notion is introduced by considering the example of Figure 11.16(a) and its equivalent form, Figure 11.16(b), and by adopting the notations of section 11.3.1.2.1.



**Figure 11.16.** (a) considered mechanical system, (b) distribution of the forces, with  $v_{c0} = j\omega C_0 f$ ,  $v_{r0} = f/r_0$ ,  $v_m = f_m/(j\omega m)$ ,  $f_r = r v_m$ ,  $f_C = v_m/(j\omega C)$ ,  $f_m = f - f_0$  and  $f_0 = f_r + f_C$



The diagram in Figure 11.16(a) can be represented by an adapted mechanical diagram, as shown in Figure 11.17, the structure of which is the “direct” image of the structure of the equivalent circuit, Figure 11.18, obtained by admittance analogy. However, it is important to note that the parallel configuration is not perfect since the excitation force  $f$  does not manifest itself in a source term in the electrical circuit.

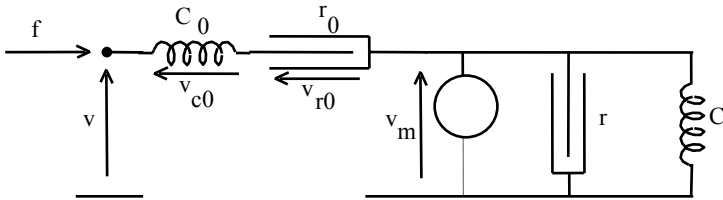

Figure 11.17. Adapted mechanical diagram

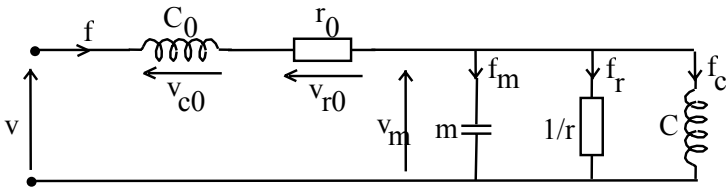
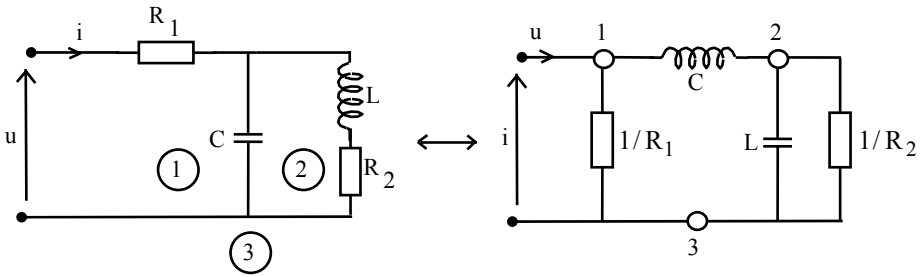

Figure 11.18. Equivalent electrical diagram obtained by admittance analogy

There exist simple techniques to obtain the equivalent electrical diagrams; however, they are beyond the scope of this book. Similarly, converting the result from one analogy to the other can be done by adopting the following method: taking a point in each loop (including the external one) of the original circuit, these points then become nodes of the new circuit and are linked together by the “transforms” of the electric lines common to their respective loop and the adjacent ones. The notion of “transform” includes both the transformation of a circuit built in series into a circuit built in parallel, of an inductance into a capacitance (and inversely), of a resistance “ $r$ ” into a resistance “ $1/r$ ”, and obviously of a voltage into a current (and inversely). However, a diagram (Figure 11.19) speaks a thousand words. This discussion, somewhat terse, on the topological duality of electrical circuits, remains limited. This section does not pretend to be exhaustive on this matter.



**Figure 11.19.** Conversion from an impedance analogy to an equivalent admittance analogy

Note: the previous discussion is entirely applicable to rotational motions where the angle  $\alpha$ , the moment force  $M$ , the moment of inertia  $J = \int \ell^2 dm$  replace, respectively, the displacement  $\xi$ , the force  $f$ , and the mass  $m$ . The other quantities, the properties and analogical circuits remain strictly the same as those previously presented.

**11.3.3. Digression on the one-dimensional mechanical systems with distributed constants: longitudinal motion of a beam**

11.3.3.1. Equations of motion

The system considered – represented in Figure 11.20 – is a beam of length  $L$ , cross-sectional area  $A$ , density  $\rho$ , and Young’s modulus  $E$ , all (apart from  $L$ ) functions of the position  $x$ . The beam is connected to a rigid frame at  $x = 0$  via a mass  $M$  and a spring of stiffness  $k$ , and at  $x = L$  via a linear dissipative resistance  $b$ .

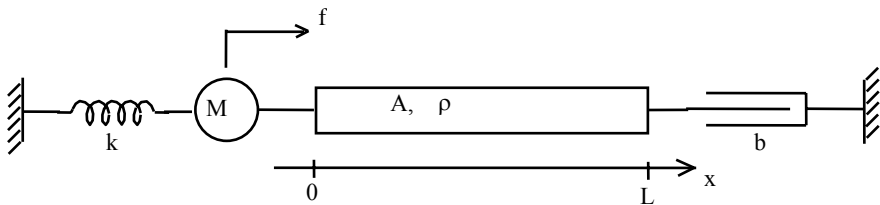

**Figure 11.20.** Beam and boundary conditions

According to the conventions adopted in section 11.3.1.2.1, the equations governing the longitudinal displacement  $\xi(x,t)$  can be obtained directly from Figure 11.21 which introduces the reaction forces between the different elements.

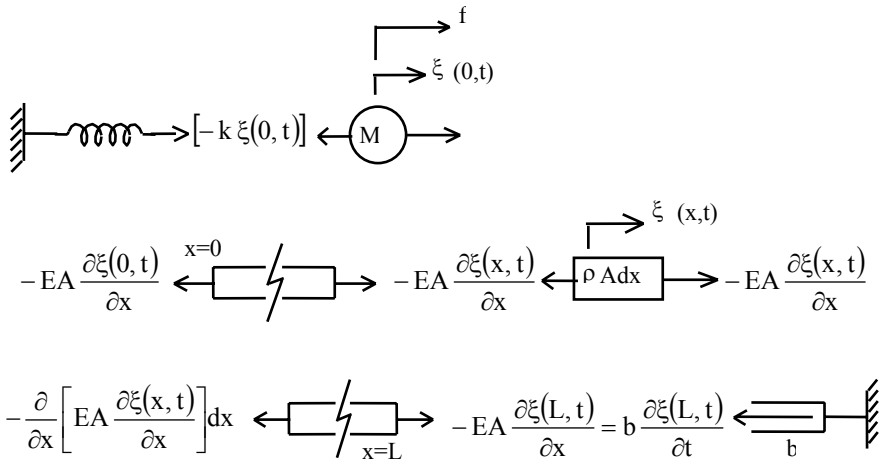

**Figure 11.21.** Reaction forces in the considered system (Figure 11.20)

One obtains

$$M \frac{\partial^2 \xi(0,t)}{\partial t^2} = EA \frac{\partial \xi(0,t)}{\partial x} - k \xi(0,t) + f, \text{ for } x = 0, \tag{11.37a}$$

$$\rho A \, dx \frac{\partial^2 \xi(x,t)}{\partial t^2} = \frac{\partial}{\partial x} \left[ EA \frac{\partial \xi(x,t)}{\partial x} \right] dx, \quad \forall x \in (0, L), \tag{11.37b}$$

$$EA \frac{\partial \xi(L,t)}{\partial x} = -b \frac{\partial \xi(L,t)}{\partial t}, \text{ for } x = L. \tag{11.37c}$$

These equations of motion can be verified using the principle of virtual work (usual notations):

$$\begin{aligned} 0 = \int_{t_1}^{t_2} dt \left( \delta \int_0^L \left[ \frac{1}{2} \rho A \left( \frac{\partial \xi}{\partial t} \right)^2 - \frac{EA}{dx} \int_0^{d\xi} (d\xi) d(d\xi)' \right] dx \right. \\ \left. + \delta \left[ \frac{1}{2} M \left( \frac{\partial \xi(0,t)}{\partial t} \right)^2 - \frac{1}{2} k (\xi(0,t))^2 \right] \right. \\ \left. + f \delta \xi(0,t) - b \frac{\partial \xi(L,t)}{\partial t} \delta \xi(L,t) \right), \end{aligned}$$

or

$$\begin{aligned}
 0 = \int_{t_1}^{t_2} dt \left( \int_0^L \left[ -\rho A \frac{\partial^2 \xi}{\partial t^2} + \frac{\partial}{\partial x} \left( EA \frac{\partial \xi}{\partial x} \right) \right] \delta \xi \, dx - EA \frac{\partial \xi(L,t)}{\partial x} \delta \xi(L,t) \right. \\
 \left. + EA \frac{\partial \xi(0,t)}{\partial x} \delta \xi(0,t) + \left[ -M \frac{\partial^2 \xi(0,t)}{\partial t^2} - k \xi(0,t) + f \right] \delta \xi(0,t) \right. \\
 \left. - b \frac{\partial \xi(L,t)}{\partial t} \delta \xi(L,t) \right), \quad \forall \delta \xi(x,t), \delta \xi(0,t), \delta \xi(L,t).
 \end{aligned}
 \tag{11.38}$$

11.3.3.2. *Circuit diagrams equivalent to the beam alone (with constant characteristics)*

Denoting  $dm = \rho A dx$  and  $dc = dx/(EA)$ , the diagram of the beam alone, the associated adapted diagram, and the equivalent electric circuit are obtained and given by Figures 11.22, 11.23 and 11.24 respectively.

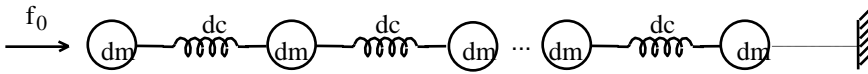

Figure 11.22. Mechanical diagram of the beam alone

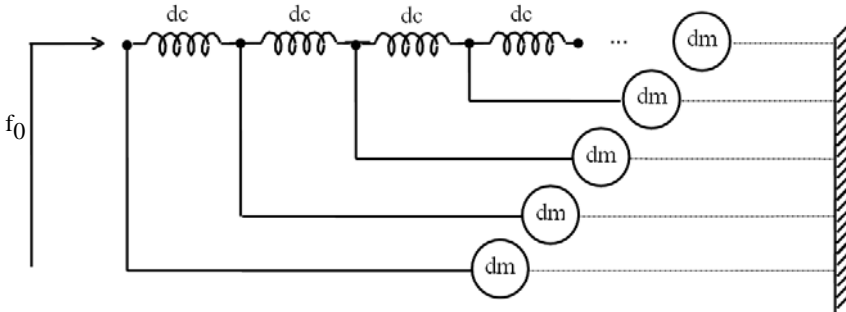

Figure 11.23. Adapted symbolic diagram of the beam alone

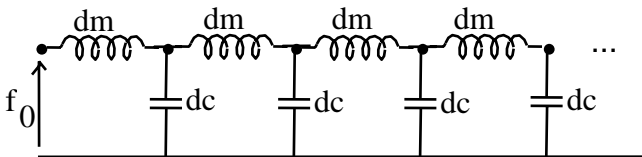

Figure 11.24. Equivalent circuit diagram

The input mechanical impedance of the system is in the form

$$Z = j\omega dm + \frac{1}{j\omega dc + \frac{1}{j\omega dm + \frac{1}{j\omega dc + \frac{1}{\dots}}}} \quad (11.39)$$

**11.4. Linear acoustic systems with localized and distributed constants**

**11.4.1. Linear acoustic systems with localized constants**

11.4.1.1. *The fundamental acoustical elements*

11.4.1.1.1. The acoustic mass

The acoustic mass is associated with the motion, here in one dimension, of a fluid element of length  $\ell$ , the dimensions of which are significantly smaller than the wavelength considered. The motion is induced by a difference  $\delta p$  between the input acoustic pressure  $p_e$  and the output acoustic pressure  $p_s$  (Figure 11.25). Euler’s linear equation (1.56) away from the sources,

$$\rho_0 \frac{\partial v}{\partial t} = - \frac{\partial p}{\partial z}, \quad (11.40)$$

becomes

$$m_a \frac{\partial w}{\partial t} = \delta p, \quad (11.41a)$$

or, in the frequency domain,

$$j\omega m_a w = \delta p, \quad (11.41b)$$

where

$m_a = \rho_0 \ell / S$  is the acoustic mass (see equation (3.160)),  
 $w = Sv$  is the acoustic flow,  
 $\delta p = p_e - p_s$ , with  $\delta p / \ell \cong -\partial p / \partial z$ .

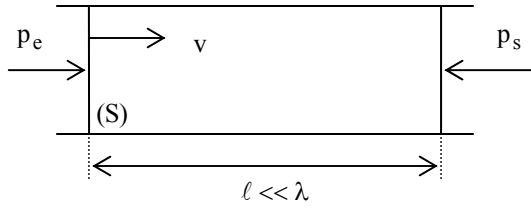

**Figure 11.25.** *The acoustic mass*

11.4.1.1.2. The acoustic compliance

The acoustic compliance is associated with the elastic reaction of a volume of fluid  $V$  (varying around a mean value  $V_0$ ), the dimensions of which are significantly smaller than the wavelength considered ( $\sqrt[3]{V} \ll \lambda$ ) and within which the density and pressure remain uniform (Figure 11.26). It is characteristic of a reaction to a flow variation through the boundary surface  $S$  associated with a uniform displacement  $\xi = \Xi / S$ .

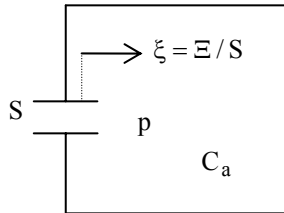

**Figure 11.26.** *The acoustic compliance*

The acoustic compliance can be expressed from the mass conservation law as follows. By considering that the density  $\rho$  is independent of the point considered,

$$0 = d(\rho V) = \rho dV + V d\rho = \rho_0 \Xi - \rho' V_0 = \rho_0 \Xi - V_0 p / c^2 \text{ (equation (1.55))},$$

$$\text{with } c_0^2 = \frac{\gamma}{\rho_0 \chi_T} = \frac{\gamma P_0}{\rho_0} \text{ (equations (1.45) and (1.52)).}$$

Thus, if one defines the stiffness  $s_a$  (or its reciprocal compliance  $C_a$ ) by

$$s_a = \frac{1}{C_a} = \frac{\gamma P_0}{V_0}, \tag{11.42a}$$

the preceding law becomes (equation (3.162))

$$p = s_a \Xi = \frac{1}{C_a} \Xi \quad \text{or} \quad p = s_a \int w dt, \quad (11.42b)$$

or, in the frequency domain,

$$p = \frac{1}{j\omega C_a} w, \quad (11.42c)$$

where  $p$  denotes the pressure variation,  $P_0$  the mean pressure, and  $V_0$  the mean volume. Equation (11.42b) is a particular case of equation (3.73).

#### 11.4.1.1.3. Acoustic resistance: capillary tubes and slots

According to the discussion in section 3.9, tubes and capillary slots, of a length significantly shorter than the wavelength, behave in a resistive way. On considering the discussion following equation (3.163b), the behavior of these capillary waveguides is governed by equation (3.149) in the frequency domain:

$$\partial p / \partial z + Z_v w = 0, \quad (11.43)$$

where  $\partial p / \partial z \cong -\delta p / \ell$  (ratio of the difference between input and output pressures to the length of the tube) and where  $Z_v$  is given by equations (3.148), (3.146) and (3.83) combined with (3.149) as

$$Z_v = \frac{1}{S} \frac{j k_0 \rho_0 c_0}{1 - K_v},$$

with

$$K_v = \frac{2}{k_v R} \frac{J_1(k_v R)}{J_0(k_v R)} \quad \text{for a cylindrical tube of radius } R,$$

$$K_v = \frac{\text{tg}(k_v \varepsilon / 2)}{k_v \varepsilon / 2} \quad \text{for a rectangular slot of thickness } \varepsilon,$$

$$k_v^2 = -i \rho_0 \omega / \mu \quad (\text{equation (2.85)}).$$

The expansions of these functions about the origin lead to the following expressions (equations (3.163a) and (3.164)):

$$\frac{\delta p}{w} \cong \frac{8\mu\ell}{\pi R^4} + j \frac{4}{3} \frac{\rho_0 \ell}{\pi R^2} \omega \cong \frac{8\mu\ell}{\pi R^4} = R_a \quad \text{for a capillary tube,} \quad (11.44a)$$

$$\frac{\delta p}{w} \cong \frac{12\mu\ell}{bh^3} + j\frac{6\rho_0\ell}{5bh}\omega \cong \frac{12\mu\ell}{bh^3} = R_a \text{ for a capillary slot of width } b \text{ and thickness } h. \tag{11.44b}$$

The behavior of these systems is resistive in nature with a resistance  $R_a$ .

The set of laws (11.41b), (11.42c), (11.44a), and (11.44b) defines the three fundamental elements of acoustic circuits of small dimensions compared with the wavelength, the acoustic mass  $m_a$ , the acoustic compliance  $C_a$ , and the acoustic resistance  $R_a$  that are widely used in electro-acoustics.

11.4.1.2. *Electro-acoustic analogies, equivalent electrical circuits*

11.4.1.2.1. Electro-acoustic analogies

The clear equivalence between mechanical and acoustical systems leads, of course, to the same electrical analogies for the acoustic systems as those presented in section 11.3.2.1. for the mechanical systems. Thus, the analogies of impedance and admittance types are briefly presented here in Table 11.1.

Acoustic quantity	Analogy of impedance	Analogy of admittance
Pressure $p$ , Flow $w$ , “Volume displacement” $\Xi$	Tension $u$ , Intensity $i$ , Charge $q$	Intensity $i$ , Tension $u$ , Indefinite integral $\int udt$
Acoustic mass $m_a$ $p = m_a \partial w / \partial t$	Inductance $L$ $u = L \partial i / \partial t$	Capacitance $C$ $i = C \partial u / \partial t$
Compliance $C_a$ $p = \frac{1}{C_a} \int wdt$	Capacitance $C$ $u = \frac{1}{C} \int idt$	Inductance $L$ $i = \frac{1}{L} \int udt$
Resistance $R_a$ $p = R_a w$	Resistance $R$ $u = R i$	Conductance $1/R$ $i = (1/R) u$
Acoustic impedance $Z_a$ $p/w = Z_a$	Impedance $Z$ $u/i = Z$	Admittance $Y$ $i/u = Y$

**Table 11.1.** *Electro-acoustic analogies*



Note: the use of the ideal converter allows the transformation of acoustic pressure  $p$  and acoustic flow  $w$  into the mechanical quantities force  $F$  and velocity  $v$ , as shown in Figure 11.27. This way, the mechanical impedance  $Z_{am}$  of an acoustic system is related to the acoustic impedance  $Z_a$  of the same system by

$$Z_{am} = \frac{F}{v} = \frac{pS}{w/S} = S^2 Z_a . \tag{11.45}$$

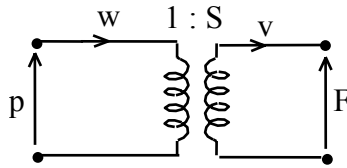

**Figure 11.27.** *Acoustical-mechanical conversion of a system*

11.4.1.2.2. Equivalent electronic circuits: some examples

The application of the principles and methods adopted for the presentation of the electromechanical conversions (section 11.3.2.2) is straightforward. Consequently, this section concerning the electro-acoustical conversions is limited to a few classic examples.

The functioning of Helmholtz resonator (Figure 11.28(a)) is governed, in the absence of a screen, by the following equation (see equations (6.235a) and (6.235b)):

$$p = m_a \frac{\partial w}{\partial t} + r_a w + \frac{1}{C_a} \int w dt = m_a \frac{\partial^2 \Xi}{\partial t^2} + r_a \frac{\partial \Xi}{\partial t} + \frac{\Xi}{C_a} , \tag{11.46a}$$

or, in the frequency domain, by

$$p = \left( j\omega m_a + r_a + \frac{1}{j\omega C_a} \right) w . \tag{11.46b}$$

The equivalent electrical circuit (impedance analogy) is given in Figure 11.28(b).

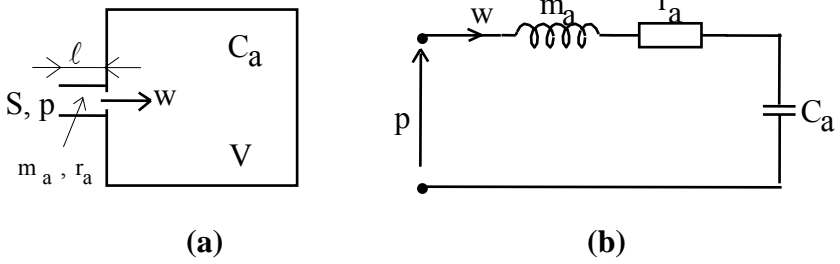

**Figure 11.28.** (a) Helmholtz resonator, and (b) equivalent electrical circuit obtained by impedance analogy

Figures 11.29(a) and (b) and 11.30(a) and (b) widen the previous results to encompass systems of Helmholtz resonators.

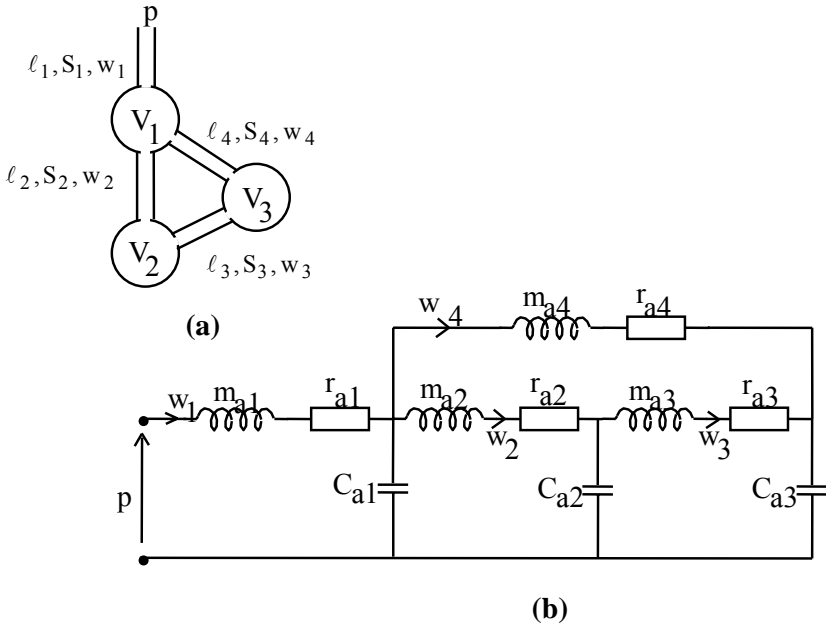

**Figure 11.29.** (a) combination of Helmholtz resonators, and (b) equivalent electrical circuit



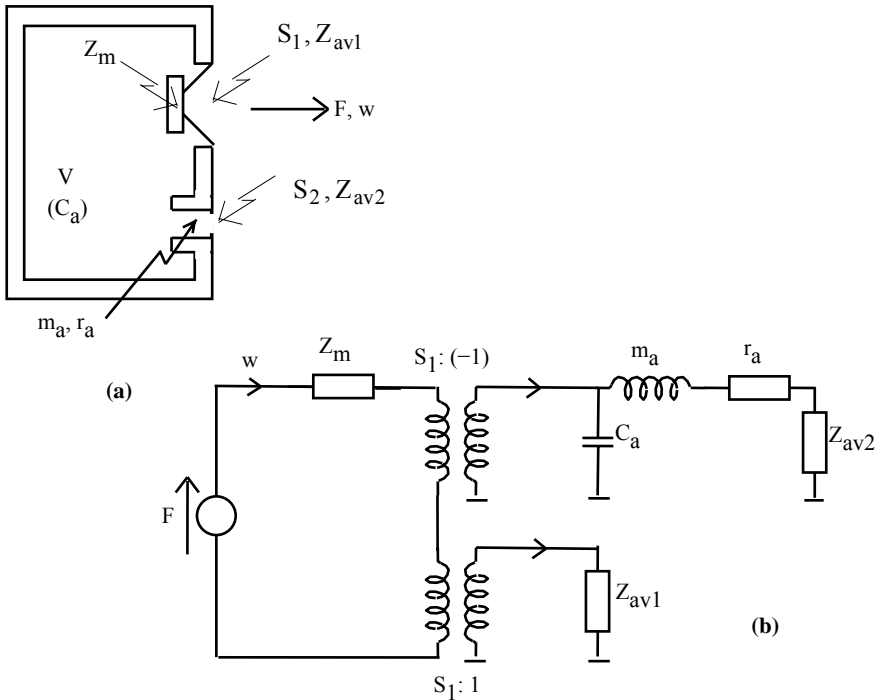

**Figure 11.32.** (a) loudspeaker built in a bass-reflex cabinet, (b) equivalent electrical circuit

**11.4.2. Linear acoustic systems with distributed constants: the cylindrical waveguide**

Following the example of the longitudinal motion of an elastic beam given in section 11.3.3, the propagation of plane waves in a cylindrical tube manifests itself as a system with distributed constants, modeled as a series of fluid elements (of infinitesimal thickness), each presenting a behavior that is elastic (stiffness  $dC_a$ ), inertial (mass  $dm_a$ ), and resistive (viscous resistance  $dr_{va}$  and thermal resistance  $dr_{ha}$ ). These characteristics are given by equations (3.149), (3.150), (3.156) and (3.157). The object here is to give the equivalent electrical circuits that are the manifestations of the behavior described in section 3.9 (equations (3.146) to (3.157)).

By adopting the common hypothesis that  $|Y_h Z_v| \ll 1$  and the change of notation ( $u \rightarrow w$ ), the circuit diagram equivalent to equations (3.149) and (3.150)

$$\frac{\partial p}{\partial z} + Z_v w = 0 \quad \text{and} \quad \frac{\partial w}{\partial z} + Y_h p = 0,$$

can be any of the forms in Figure 11.33.

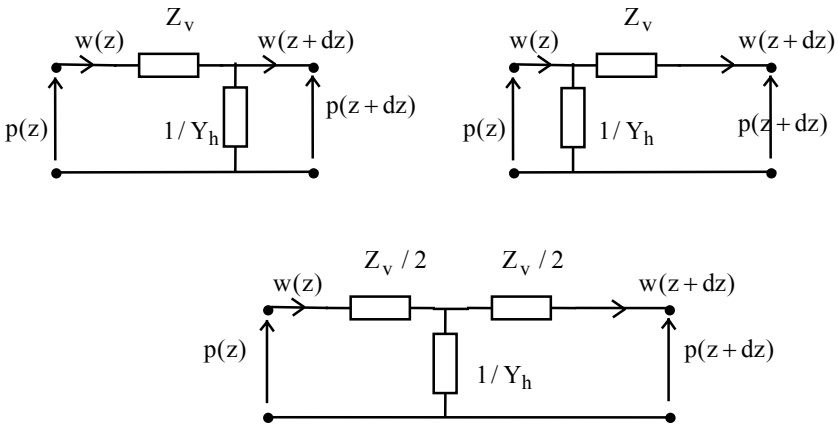

**Figure 11.33.** Equivalent quadrupoles for plane waves propagation in a tube ( $|k_{h,v}R| > 10$ )

The asymptotic expressions (3.156) and (3.157) for “large” tubes ( $|k_{h,v}R| > 10$ ) of  $Z_v$  and  $Y_h$  can be written in the following forms:

$$Z_v = dR_{va} + j\omega d m_a, \tag{11.47a}$$

$$Y_h = \frac{1}{dR_{ha}} + j\omega d C_a, \tag{11.47b}$$

with

$$dm_a \cong \rho_0 dz / S \text{ and } S = \pi R^2 \text{ (elementary acoustic mass),}$$

$$dR_{va} \cong \frac{\sqrt{2\rho_0\omega\mu}}{\pi R^3} \text{ (elementary viscous resistance),}$$

$$dC_a \cong \frac{Sdz}{\rho_0 c_0^2} = \frac{Sdz}{\gamma P_0} = \frac{dV_0}{\gamma P_0} \text{ (elementary acoustic compliance),}$$

$$\frac{1}{dR_{ha}} \cong (\gamma - 1) \frac{\pi R}{\rho_0 c_0^2} \sqrt{\frac{2\lambda\omega}{\rho_0 C_p}} dz \text{ (reciprocal of the elementary thermal resistance).}$$

The equivalent electrical diagrams for  $Z_v$  and  $1/Y_h$  are given in Figure 11.34.

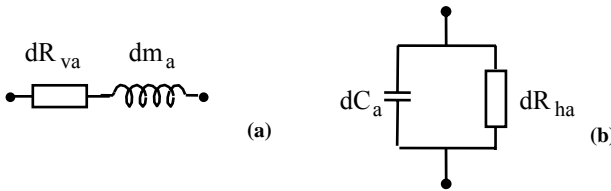

**Figure 11.34.** (a) representation of the impedance  $Z_v$ , (b) of the impedance  $1/Y_h$

### 11.5. Examples of application to electro-acoustic transducers

Three examples of transducers (loudspeakers or microphones) are addressed in this brief, but complete, presentation: the electrodynamic transducer (microphone or loudspeaker); the electrostatic microphone; and the “cylindrical” piezoelectric transducer. The systems considered here being “complete”, the electrical circuits appear in all cases closed.

#### 11.5.1. Electrodynamic transducer

##### 11.5.1.1. The transducer

An electrodynamic transducer is made of:

(i) a membrane (emitting or receiving) of mass  $M_m$  and surface area  $S_m$  under the action of a force  $F - F_a + f_i$  (see conventions on Figure 11.35), where:

$$F = pS_m \text{ is the force exerted by the pressure variation in the exterior fluid,}$$



and the total acoustic resistance

$$r_a = r_{a1} + r_{a2}, \tag{11.50}$$

respectively.

When the transducer works as a receiver, the component noted  $X_A$  is active (pressure generator) and the component  $X_E$  is passive (input impedance of the electric charge); when the transducer works as an emitter, the situation is the inverse: the component  $X_A$  is passive (impedance  $Z_r$  of the acoustic load) and the component  $X_E$  is active (Thevenin's generator  $e_g, R_g$ ).

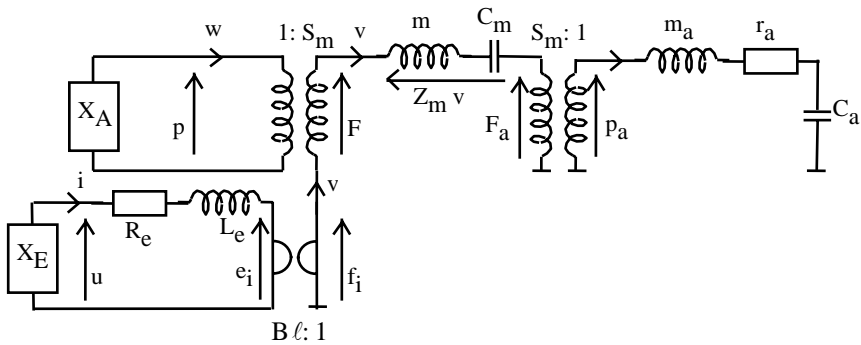

**Figure 11.36.** Equivalent electrical circuit (admittance) of an electrodynamic transducer (input and output are, in both pictures, on the left-hand side of the diagram)

### 11.5.1.2. The loudspeaker

In the forthcoming discussion, the following notations will be adopted:

$$Z_a = j\omega m_a + r_a + \frac{1}{j\omega C_a}, \tag{11.51}$$

$$Z_A = S_m^2 (Z_a + Z_r), \tag{11.52}$$

$$Z_M = j\omega m + \frac{1}{j\omega C_m} + S_m^2 Z_a = Z_m + S_m^2 Z_a, \tag{11.53}$$

$$Z_e = R_e + j\omega L_e. \tag{11.54}$$

These notations lead, when the transducer works as a loudspeaker (emitter), to

$$-(F - F_a) = S_m P_a - S_m P = +S_m^2 (Z_a + Z_r) v = Z_A v, \tag{11.55a}$$

$$f_i + F - F_a = Z_m v. \tag{11.55b}$$



The substitution of equation (11.55b) into equation (11.55a) gives

$$f_i = (Z_m + Z_A) v, \tag{11.56}$$

or, since  $f_i = B \ell i$ ,

$$v = \frac{B \ell i}{Z_m + Z_A}. \tag{11.57}$$

The substitution of equation (11.57) into:

$$e_g = B \ell v + (R_g + Z_e) i, \tag{11.58}$$

leads to

$$e_g = \left[ R_g + Z_e + \frac{B^2 \ell^2}{Z_m + Z_A} \right] i. \tag{11.59}$$

The electric impedance  $B^2 \ell^2 / (Z_m + Z_A)$  is called “motional impedance” and is, in particular, responsible for the significant variation of the impedance ( $e_g / i$ ) around the mechanical resonance frequency. By denoting  $f_a = F - F_a$  the acoustically-induced force ( $f_a = -f_i + Z_m v$ ), the above relations lead also to the following system of equations (adapted to the functioning as an emitter):

$$\begin{pmatrix} e_g \\ f_a \end{pmatrix} = \begin{pmatrix} R_g + Z_e & B \ell \\ -B \ell & Z_m \end{pmatrix} \begin{pmatrix} i \\ v \end{pmatrix}. \tag{11.60}$$

The above equations satisfy the equivalent electrical circuit in Figure 11.36, summarized in Figure 11.37.

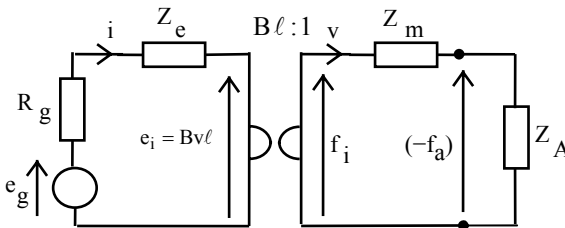
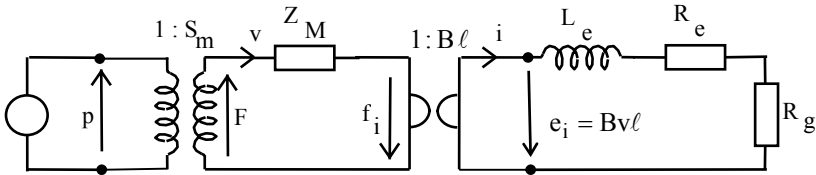

**Figure 11.37.** Representation of the system of equations (11.60)

11.5.1.3. *The microphone*

The analogical circuit of Figure 11.36 leads directly the circuit presented in Figure 11.38 where

$$\begin{aligned}
 \frac{1}{Y_M} &= Z_M = j\omega m + \frac{1}{j\omega C_m} + S_m^2 Z_a, \\
 &= j\omega m + \frac{1}{j\omega C_m} + j\omega S_m^2 m_a + S_m^2 r_a + \frac{S_m^2}{j\omega C_a}, \\
 &= j\omega(m + S_m^2 m_a) + S_m^2 r_a + \frac{C_m C_a / S_m^2}{j\omega(C_m + C_a / S_m^2)}.
 \end{aligned}
 \tag{11.61}$$



**Figure 11.38.** Representation of the microphone

11.5.1.4. *Discussion*

11.5.1.4.1. Pressure sensitivity of a microphone

The pressure sensitivity  $\eta$  of a microphone is directly derived from equation (11.61) as

$$\eta = \frac{e_i}{p} = Bl S_m Y_M = \frac{Bl S_m}{j\omega m_x + r_x + \frac{1}{j\omega C_x}},
 \tag{11.62}$$

(the expressions of the quantities  $m_x$ ,  $r_x$  and  $C_x$  are easily obtained from equation (11.61)). The representation of the admittance  $Y_M$  in logarithmic scale is given by Figure 11.39.

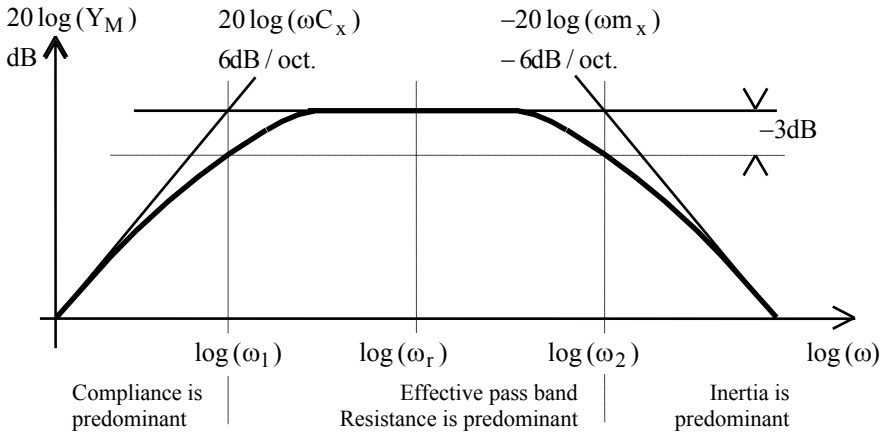

**Figure 11.39.** Pressure sensibility of an electrodynamic microphone

The behavior of this type of microphone is resistive. A wide pass-band

$$\Delta\omega = \omega_2 - \omega_1 = \frac{r_x}{m_x} - \frac{1}{r_x C_x},$$

implies that the resistance  $r_x$  has a large value. However, a high sensitivity (depending on  $1/r_x$  for  $\omega = \omega_r = 1/\sqrt{m_x C_x}$ ) implies a “small” resistance. A compromise should therefore be made. The angular frequencies  $\omega_1$  and  $\omega_2$  are cut-off frequencies at -3dB, or, in terms of levels,

$$-\left[ 20 \log \frac{1}{r_x} - 20 \log \frac{1/r_x}{|1+j|} \right] = 20 \log \frac{1}{\sqrt{2}} = -3\text{dB}.$$

11.5.1.4.2. Pressure output of a loudspeaker

A similar approach as above can be adopted to calculate the efficiency of a loudspeaker with respect to the frequency. This efficiency can be directly obtained from equations (11.58) and (11.55a and b) and from the expression of the radiation impedance  $Z_{rad} = -S_m P / v = S_m^2 Z_r$ . Thus

$$\frac{p}{-e_g} = \frac{B\ell}{S_m(R_g + Z_e)} \frac{Z_{rad}}{Z_{rad} + Z_M + \frac{B^2\ell^2}{R_g + Z_e}}.$$

For a radiation impedance corresponding to a radiation in an infinite space (Rayleigh's radiation impedance for example, equation (6.151)), this type of loudspeaker presents the behavior illustrated in Figure 11.40.

Note: for a loudspeaker to exhibit such output, the membrane area must be greater than that shown in Figure 11.35.

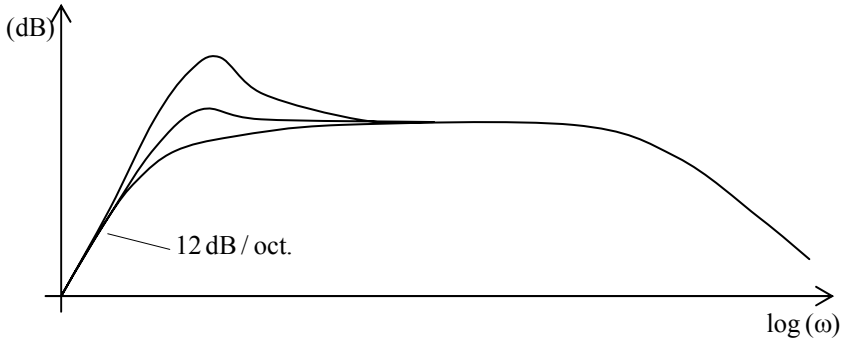

**Figure 11.40.** Pressure output of an electrodynamic loudspeaker according to the frequency (logarithmic scales)

The behavior of such a loudspeaker at low frequencies is of the second order and resistive in the normal area of use. The compliance of the mobile part governs the output of the loudspeaker at low frequencies while its inertia is predominant at high frequencies. In the effective pass-band, the efficiency is limited to a few percent by a small radiation resistance compared to the mechanical resistance of the system.

Typically, the pass band spreads over three to six octaves, even if in practice two to three loudspeakers are used to cover the audible range. When working as a receiver, a diaphragm of small dimensions is enough, widening the frequency range to higher frequencies.

### 11.5.2. The electrostatic microphone

An electrostatic microphone is made of:

- (i) a diaphragm of mass  $m_m$ , compliance  $C_m$  and surface area  $S$  under the action of an external acoustic pressure  $p$ ;
- (ii) a perforated back electrode (grid) characterized by the acoustic mass  $m_{a1}$  of the fluid in the perforations and by the associated acoustic resistance  $r_{a1}$ ;
- (iii) a “quasi-closed” back cavity of compliance  $C_{a1}$ ; and

(iv) a capillary aperture equalizing the static pressure characterized by its radiation impedance  $Z_{a2}$ , its acoustic mass  $m_{a2}$ , and its acoustic resistance  $r_{a2}$  (that tends to infinity above few hertz).

The system delivers an electric signal  $u$  (voltage) to the electrical frame represented in Figure 11.14. In this assembly, a high resistance  $R_p$  avoids the short-circuit for the signal  $u$  and maintains the polarization  $U_0$  required for the microphone to operate (section 11.2.4). The high capacitance  $C_L$  provides the decoupling of the continuous signal between the “front” and the “back” halves of the assembly while presenting a short-circuit for the signal  $u$ . The impedance  $Z_s$  represents the input impedance of the preamplifier.

It is convenient here to note that the same system can be used as an emitter. Then, a voltage generator  $e_s = -u + Z_s i$  must be inserted in the circuit line containing the impedance  $Z_s$  and the pressure generator must be replaced by the radiation impedance.

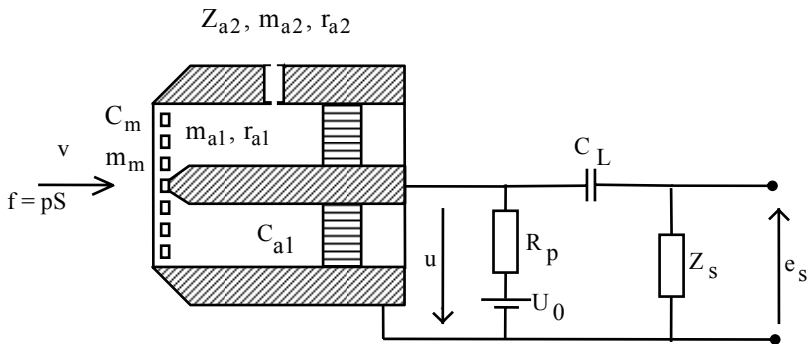
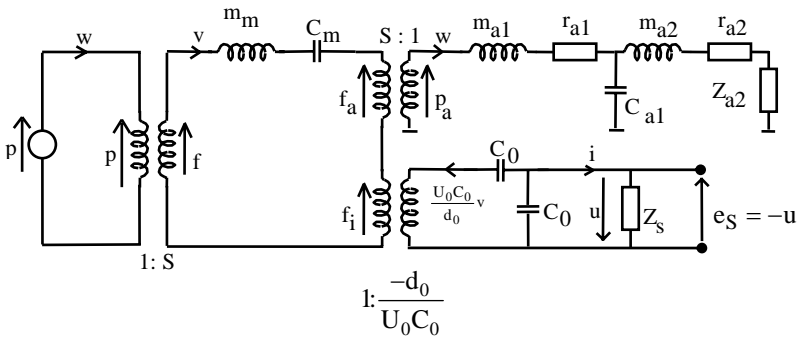

Figure 11.41. Electrostatic microphone

The equivalent electric diagram of this (the electric polarization is not shown) microphone, obtained using the same approach as in section 11.2.4 and in particular equation (11.33) and Figure 11.8, is given in Figure 11.42.

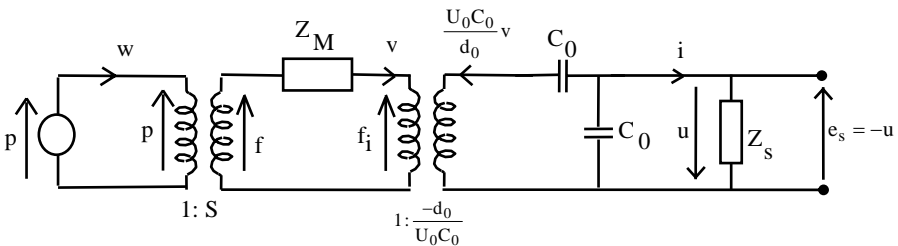

**Figure 11.42.** Equivalent electric circuit of an electrostatic microphone

By denoting the acoustic impedance  $Z_a$  of the circuit containing the factors  $m_{a1}$ ,  $r_{a1}$ ,  $m_{a2}$ ,  $r_{a2}$ ,  $C_{a1}$  and  $Z_{a2}$  (top right of Figure 11.42) and  $Z_m$  the impedance associated to the factors  $m_m$  and  $C_m$  ( $Z_m = j\omega m_m + 1/(j\omega C_m)$ ), the mechanical impedance  $Z_M$  of the mechano-acoustical assembly is given by

$$Z_M = Z_m + S^2 Z_a, \tag{11.63}$$

and the analogical circuit of Figure 11.42 is reduced to the one in Figure 11.43.



**Figure 11.43.** Equivalent electrical circuit of an electrostatic microphone

The equations of coupling (11.33a and b), according to the fact that

$$f = f_i + Z_M v, \tag{11.64}$$

become

$$u = \frac{1}{jC_0\omega} i + \frac{1}{j\omega d_0/U_0} v, \quad (11.65a)$$

$$f = \frac{1}{j\omega d_0/U_0} i + Z_M v. \quad (11.65b)$$

If one writes that  $f = pS$ ,  $i = -u/Z_s$  and eliminates the variable  $v$  in both equations, it leads to

$$\frac{p}{u} = \left( \frac{d_0 Z_M}{C_0 U_0} - \frac{1}{j\omega d_0/U_0} \right) \frac{1}{SZ_s} + \frac{j\omega d_0}{SU_0} Z_M.$$

By considering that the value of the input impedance  $Z_s$  of the preamplifier is always great ( $Z_s \rightarrow \infty$ ), the above equation leads to the following expression of the microphone's efficiency  $\eta$ :

$$\eta = \frac{e_s}{p} \cong j \frac{U_0 S}{d_0} \frac{1}{\omega Z_M}. \quad (11.66)$$

The study of the function  $(\omega Z_M)$ , written in the form

$$\omega Z_M = jM\omega^2 + R_M\omega + \frac{1}{jC_M},$$

shows that the microphone exhibits:

(i) an elastic behavior at low frequencies since

$$\frac{1}{|\omega Z_M|} \cong C_M \text{ for } \omega \ll \frac{1}{\sqrt{MC_M}};$$

(ii) an inertial behavior at high frequencies since

$$\frac{1}{|\omega Z_M|} \cong \frac{1}{M\omega^2} \text{ for } \omega \gg \frac{1}{\sqrt{MC_M}};$$

(iii) a resistive behavior at the frequency  $\omega = \frac{1}{\sqrt{MC_M}}$ ,

$$\frac{1}{|\omega Z_M|} \cong \frac{\sqrt{MC_M}}{R_M}$$

It is only at low frequencies that the efficiency is frequency independent (Figure 11.44): the microphone then behaves elastically within the effective pass-band. A more detailed study of the impedance  $Z_M$  shows that the presence of pressure equalizing perforations ( $Z_{a2}, m_{a2}, r_{a2}$ ) triggers the efficiency drop at the vicinity of  $\omega = 0$  (typically for frequencies smaller than 1 Hz). In practice, the cut-off frequency  $1/\sqrt{MC_M}$  takes a value between 20 kHz and 200 kHz depending on the type of microphone.

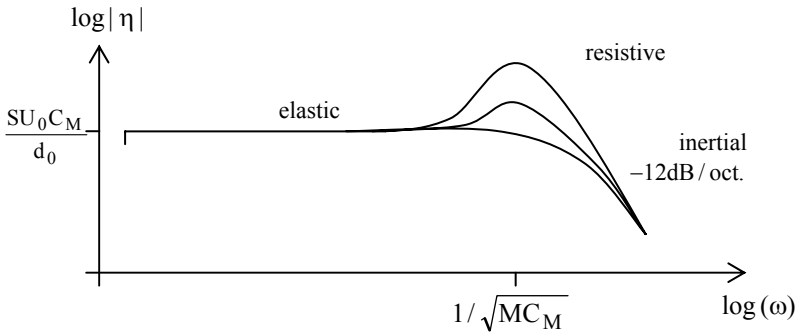

**Figure 11.44.** Efficiency of an electrostatic microphone with respect to frequency (logarithmic scales)

Note: used as an emitter, the behavior of an electrostatic transducer is still governed by the same coupling equations (11.65). However,  $u = Z_s i - e_s$  (Thevenin's generator  $e_s$ ,  $Z_s$  at the input) and  $f = Z_{rad} v$  (where  $Z_{rad}$  represents the mechanical radiation impedance). The efficiency  $r$  of the loudspeaker is then characterized by

$$r = \frac{p}{(-e_s)} = \frac{Z_{ray} v}{S e_s} = - \frac{C_0 U_0}{S d_0} \frac{Z_{ray}}{Z_{ray} + Z_M - \frac{C_0 U_0^2}{j \omega d_0^2}}$$



### 11.5.3. Example of piezoelectric transducer

By adding the inertia of the piezoelectric membrane and the reactions from the internal ( $r < R$ ) and external ( $r > R$ ) acoustic media, the problem considered here becomes the one described in section 11.2.2. To the coupling equations (11.21a and b) in the frequency domain

$$u = \frac{1}{j\omega C_0} i - \frac{1}{j\omega C_0 / K_0} v, \quad (11.67a)$$

$$f_i = \frac{1}{j\omega C_0 / K_0} i - \frac{1}{j\omega} \left( \frac{1}{C} + \frac{K_0^2}{C_0} \right) v, \quad (11.67b)$$

one needs to associate the fundamental law of dynamics (equilibrium of the forces), that is, denoting  $m = hbR\varphi\rho$  the mass of the membrane,

$$mj\omega v = f_i + bR\varphi(p_{\text{int}} - p_{\text{ext}}), \quad (11.68)$$

where the left-hand side term represents the inertial force and the right-hand side term contains the piezoelectric force  $f_i$ , where  $p_{\text{ext}}$  is the external pressure (created or imposed according to whether the transducer works as an emitter or receiver) and where the internal pressure  $p_{\text{int}}$  is expressed as a function of the impedance  $Z_{\text{int}}$  of the back cavity

$$p_{\text{int}} = -Z_{\text{int}} v. \quad (11.69)$$

The set of equations (11.67) to (11.69) leads to the following coupling equations:

$$i = K_0 v + j\omega C_0 u, \quad (11.70a)$$

$$K_0 u = \left( j\omega m + \frac{1}{j\omega C} \right) v + bR\varphi(Z_{\text{int}} v + p_{\text{ext}}). \quad (11.70b)$$

The equivalent electrical diagram is immediately obtained and is represented in Figure 11.45, completed on the left-hand side by a Thevenin's generator, if working as an emitter ( $e_g = 0$  if working as a receiver,  $Z_g$  representing then the input impedance of the charge amplifier), and completed on the right-hand side (element noted G) by the acoustic radiation impedance  $bR\varphi Z_{\text{ext}}$  if working as an emitter and by a pressure generator  $p_{\text{ext}}$  otherwise.

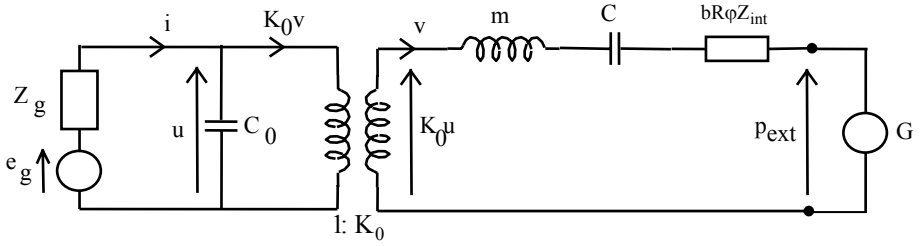

**Figure 11.45.** *Equivalent electrical circuit of a piezoelectric transducer*

The derivations of the efficiency, when the transducer works as a receiver and emitter, are similar to those presented in sections 11.5.1 and 11.5.2.

## Chapter 11: Appendix

### A.1. Reminder about linear electrical circuits with localized constants

The notations used in this Appendix are universal and will consequently not be explained. Nevertheless, it is convenient to note that the electric potential represented by an arrow is defined by the potential at the head minus the potential at the tail of the arrow.

The three fundamental poles in electricity are (Figure 11.46(a), (b) and (c)):

- (i) the resistance  $R = u / i$  , dissipating the energy  $Ri^2$  ;
- (ii) the capacitance  $C = \frac{1}{u} \int i dt$  , storing the energy  $\frac{1}{2}Cu^2$  ; and
- (iii) the inductance  $L = \frac{u}{di/dt}$  , storing the energy  $\frac{1}{2}Li^2$  .

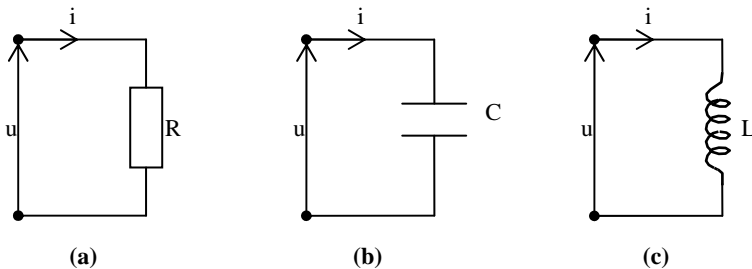

**Figure 11.46.** *The three fundamental electrical dipoles: the resistance (a), the capacitance (b) and the inductance (c)*

While the ideal converter (Figure 11.47(a)) satisfies

$$\frac{n_1}{n_2} = \frac{u_1}{u_2} = \frac{i_2}{i_1} = \frac{\sqrt{u_1/i_1}}{\sqrt{u_2/i_2}} = \sqrt{\frac{Z_1}{Z_2}},$$

the gyrator circuit (Figure 11.47(b)) satisfies

$$\frac{n_1}{n_2} = \frac{u_1}{i_2} = \frac{u_2}{i_1}.$$

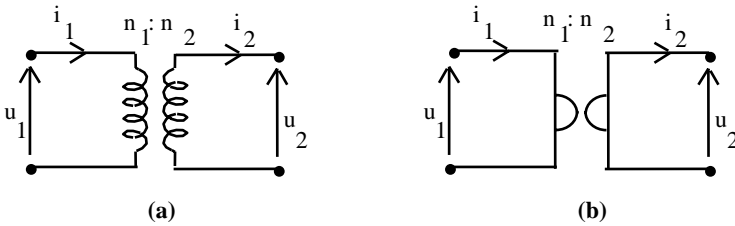

Figure 11.47. Ideal converter (a), and gyrator (b)

The Thevenin's generator charged by the impedance  $Z_c$  (Figure 11.48(a)) satisfies the following equations:

$$u_s = \frac{Z_c}{Z_c + Z_i} u \text{ and } i_s = \frac{1}{Z_c + Z_i} u,$$

while the Norton's generator, charged by the impedance  $Z_c$  (Figure 11.48(b)) satisfies

$$u_s = \frac{Z_i Z_c}{Z_i + Z_c} i \text{ and } i_s = \frac{u_s}{Z_c} = \frac{Z_i}{Z_i + Z_c} i.$$

There is complete equivalence between these equations if  $u = Z_i i$ .

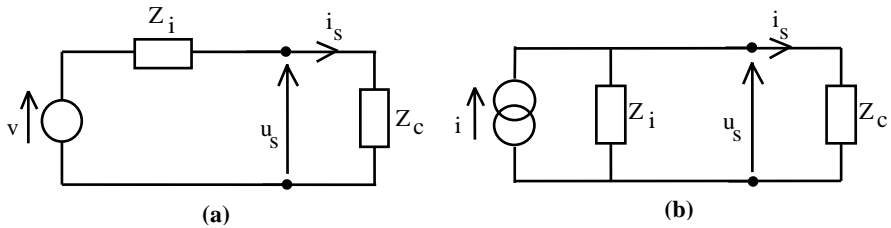

**Figure 11.48.** *Thevenin's generator (a), and Norton's generator (b)*

The local electrical behavior of a line with distributed constants (such as coaxial cables, for example) presents the profile given in Figure 11.49.

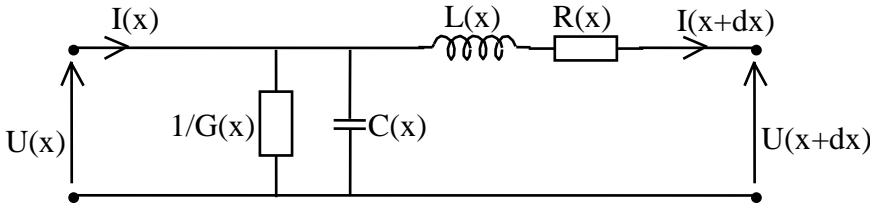

**Figure 11.49.** *Equivalent electrical diagram of an element  $dx$  of a line with distributed constants*

### A.2. Generalization of the coupling equations

The electromagnetic (11.14), piezoelectric (11.21), electrodynamic (11.60), and electrostatic (11.65) coupling equations can be written in the general form

$$e = Z_e i + Z_{em} v,$$

$$f = Z_{me} i + Z_m v,$$

with  $Z_{em} = -Z_{me}^*$ , where  $e$  and  $i$  are electrical quantities (voltage and current) and where  $f$  and  $v$  are mechanical quantities (external force applied to the mobile assembly and velocity).

The property  $Z_{em} = -Z_{me}^*$  can be demonstrated by writing the energy balance of the system. If one assumes, for example, that the source of energy of the system

is the generator of voltage “e” and one writes the energy equations associated with equations (11.71), one obtains

$$\operatorname{Re}(e i^*) = \operatorname{Re}(Z_e) |i|^2 + \operatorname{Re}(Z_{em} v i^*),$$

$$\operatorname{Re}(f v^*) = \operatorname{Re}(Z_{me} i v^*) + \operatorname{Re}(Z_m) |v|^2.$$

The interpretation of these equations is the following:

$\operatorname{Re}(e i^*)$  represents the energy provided by the electric generator,

$\operatorname{Re}(Z_e) |i|^2$  represents the energy dissipated by electric Joule effect,

$\operatorname{Re}(Z_{em} v i^*)$  represents the electrical energy converted into mechanical energy,

$[-\operatorname{Re}(f v^*)]$  represents the mechanical energy dissipated by radiation, for example,

$\operatorname{Re}(Z_m) |v|^2$  represents the mechanical energy dissipated by friction,

$[-\operatorname{Re}(Z_{me} i v^*)]$  represents the energy received by the mechanical system of electrical origin.

From this interpretation, one can easily deduce that:

$$\operatorname{Re}(Z_{em} v i^*) = -\operatorname{Re}(Z_{me} i v^*),$$

$$\text{or } \operatorname{Re}(Z_{em} v i^*) = -\operatorname{Re}(Z_{me}^* i^* v),$$

$$\text{thus } \operatorname{Re}(Z_{em} + Z_{me}) \operatorname{Re}(v i^*) = \operatorname{Im}(Z_{em} - Z_{me}) \operatorname{Im}(v i^*).$$

This equality is only verified if each term is equal to zero, which implies the sought relationship

$$Z_{em} = -Z_{me}^*.$$

*This page intentionally left blank*

## Bibliography

- ABRAMOWITZ M., STEGUN L.A., *Handbook of Mathematical functions*, Dover, 1965.
- ALLARD J.-F., *Propagation of Sound in Porous Media*, Elsevier Applied Science, 1993.
- BERANEK L., *Acoustics*, American Institute of Physics, 1954.
- BOUASSE H., *Tuyaux et résonateurs*, Blanchard, 1986.
- BOUIX M., *Les discontinuités du rayonnement électromagnétique*, Dunod, 1960.
- BRACEWELL R., *The Fourier Transform and its Applications*, McGraw-Hill, 1948.
- BREKHOVSKIKH L.M., *Waves in Layered Media*, Academic Press, 1980.
- BRILLOUIN L., *Wave Propagation and Group Velocity*, Academic Press, 1960.
- BRUNEAU M., *Manuel d'Acoustique Fondamentale*, Hermès, 1998.
- CREMER L., *The physics of the Violin*, MIT Press Cambridge, 1984.
- CREMER L., HECKL M. and UNGAR E.E., *Structure-Borne Sound*, Springer-Verlag, 1973.
- DOWLING A.P., FLOWERS WILLIAMS J.E., *Sound and Sources of Sound*, Ellis Horwood, 1983.
- FAHY F., *Sound and Structural Vibration*, Academic Press London, 1985.
- FILIPPI P. et al., *Acoustique Générale*, Les Editions de Physique, 1994.
- FLETCHER N., *The Physics of Musical Instruments*, Springer-Verlag, 1991.
- FOCK A., *Acoustique*, Armand Colin, 1934.
- GERMAIN P., *Mécanique, vol. 1 & 2, coll. Cours de l'Ecole Polytechnique*, Ellipses, 1986.
- GESPA N., *La diffusion acoustique par des cibles élastiques*, Cedocar, 1987.
- GOLDSTEIN M.E., *Aeroacoustics*, McGraw-Hill, 1976.
- GUELFAND I.M., CHILOV G.E., *Les distributions*, Dunod, 1962.
- GUSEV V., KARABUTOV A., *Laser Optoacoustics*, American Institute of Physics, 1993.
- JESSEL M., *Acoustique théorique*, Masson, 1973.
- JONES D., *Acoustic and Electromagnetic Waves*, Clarendon Press, 1986.



- JULLIEN Y., *Vibrations des systèmes élastiques*, GALF-Naturalia biologica, 1971.
- JUNGER M.C., PERULLI M., *Eléments d'acoustique physique*, Maloine, 1978.
- KUTTRUFF H., *Room Acoustics*, E&FN SPON, 1991.
- LESUEUR C., *Rayonnement acoustique des structures*, Eyrolles, 1988.
- LIENARD P., *Décibels et indices de bruit*, Masson, 1974.
- LIGHTHILL J., *Waves in Fluids*, Cambridge University Press, 1978.
- MASON W.P., THURSTON R.N., *Physical Acoustics*, Academic Press, 1984.
- MERHAUT J., *Theory of Electroacoustics*, McGraw-Hill, 1981.
- MEYER E., *Physical and Applied Acoustics*, Academic Press, 1972.
- MIKLOWITZ J., *The Theory of Elastic Waves and Waveguides*, North Holland, 1978.
- MORSE P.M., FESHBACH H., *Methods of Theoretical Physics*, McGraw-Hill, 1953.
- MORSE P.M., INGARD K.U., *Theoretical Acoustics*, McGraw-Hill, 1968.
- MUNJAL M., *Acoustics of Ducts and Mufflers*, John Wiley, 1987.
- NELSON P., *Active Control of Sound*, Academic Press, 1992.
- PIERCE A.D., *Acoustics: an Introduction to its Physical Principles and Applications*, McGraw-Hill, 1981.
- RAYLEIGH J.W.S., *The Theory of Sound*, Dover, 1945.
- RODDIER F., *Distributions et Transformations de Fourier*, Ediscience, 1971.
- ROSSI M., *Electroacoustique, Traité d'Electricité de l'Ecole Polytechnique de Lausanne*, Vol. XXI, Presses Polytechniques Romandes, 1986.
- ROYER D., DIEULESAINT E., *Ondes élastiques dans les solides. Propagation libre et guidée*, Masson, 1996.
- RUDENKO D.V., SOLUYAN S.I., *Theoretical Foundations of Non-Linear Acoustics*, Plenum Publishing, 1977.
- SAINT-JEAN B., *Electrotechnique et machines électriques*, Eyrolles, 1977.
- SCHWARTZ L., *Théories des distributions*, Hermann, 1966.
- SKUDRZYK E., *Simple and Complex Vibratory Systems*, The Pennsylvania State University Press, 1968.
- SKUDRZYK E., *The Foundations of Acoustics*, Springer-Verlag, 1971.
- ŠKVOR Z., *Vibrating Systems and their Equivalent Circuits*, Elsevier, 1991.
- SNOWDON J.-C., *Vibration and Shock in Damped Mechanical Systems*, John Wiley, 1968.
- TEMKIN S., *Elements of Acoustics*, John Wiley, 1981.
- TIMOSHENKO S., YOUNG D.H., WEAVER W.J.R., *Vibration Problems in Engineering*, John Wiley, 1974.
- ZWIKKER I., KOSTEN C.W., *Sound Absorbing Materials*, Elsevier, 1949.

# Index

## A, B

acoustic  
  non-linear, 511  
  systems, 604  
adiabatic, 36  
analytical signal, 466  
  approximation, 34  
Babinet's principle, 364  
beam, 601  
Bessel functions  
  cylindrical, 230  
  spherical, 248  
boundary, 42, 112  
  conditions, 85  
  layer, 84, 89, 112  
Bürger's equation, 537

## C

capillary  
  cylindrical tube, 146  
  slit, 140  
Cartesian coordinates, 169  
cavity, 131, 336  
  circular waveguide, 238  
  rectangular, 481  
  small, 131, 320  
  spherical, 262  
closed spaces, 465  
  frequency domain, 468

  time domain, 478  
compressibility, 27  
  conservation, 101  
Curle's solution, 570  
cylindrical  
  coordinates, 227  
  guide, 141, 148

## D

damping, 19  
decibels, 18  
deformation, 57  
diffraction  
  by a screen, 362  
  by a semi-infinite screen (edge),  
  369  
  by a straight edge, 376  
  cylinder (by a), 236  
  diffused field, 497, 504  
  Keller's theory, 379  
  MacDonald's theory, 374  
  Sommerfeld's theory, 371, 374  
  sphere (by a), 258  
diffusion  
  bulk, 357  
  surface, 360  
dipole, 254  
Dirac notation, 223  
discontinuities, 102, 206

dispersion relation, 560  
 dissipation process, 170  
 dissipative fluid, 77, 111, 170  
 Doppler effect, 547

## E

eigenvalue problems, 217  
 electrical circuits, 626  
 electroacoustics, 577  
   analogies, 607, 612  
   conversions, 591  
 electrodynamic  
   conversion, 578, 588, 591  
   transducer, 613, 617  
 electromagnetic conversion, 578  
 electromechanical analogies, 596, 601  
 electrostatic  
   conversion, 589  
   microphone, 619  
 energy, 30, 43, 68  
   conservation of, 30, 102  
   density, 43, 203  
   flow, 43  
   flux, 203  
   kinetic, 68  
   potential, 68  
   transfer, 557  
 enthalpy, 69  
 entropy, 56  
   continuity equation, 56  
   equation, 79, 102  
   motion, 112  
 equation of propagation, 33, 79  
 Euler equation, 29  
 Eulerian description, 25

## F

Fermat's principle, 403  
 fractional derivatives, 545  
 Fraunhofer's approximation, 333, 364  
 frequency, 17

Fresnel's  
   approximation, 334, 366  
   integrals, 335, 369  
 Fubini's solution, 531

## G, H

Green's function, 118, 279, 553  
 gyrometer (acoustic), 163  
 Hankel functions  
   cylindrical, 230  
   spherical, 248  
 heat diffusion, 69, 85  
   Fourier equation, 69  
 Helmholtz resonator, 342  
   absorption, 353  
   amplification, 354  
   diffusion, 352  
   reverberation, 351  
 horn, 210  
 Huygens's principle, 315

## I

impedance, 40  
 initial values problems, 310  
 integral formalism, 277, 296, 551  
 intensity, 18, 241  
 interface, 187  
   conditions, 106  
   fluid-solid reflection and transmission, 450

## L

Lagrangian description, 25  
 layer, 136  
   thin fluid, 136  
 Lechatelier's law, 24  
 Lighthill's equation, 568  
 linear, 34  
   longitudinal, 410  
 linearization method, 513  
 loudspeaker, 615  
   radiation, 330

**M, N**

mass conservation law, 27  
 mechanical systems, 592  
 membrane, 313, 318, 409, 419  
 modal  
   coupling, 477  
   density, 483  
   theory, 206, 239  
 monopole, 254  
   motion, 112  
 motion driving, 17  
 moving source, 309  
 multipole, 273  
 Navier-Stokes, 56  
   equation, 56  
 Neumann functions  
   cylindrical, 231  
   spherical, 248  
 non-homogeneous media  
   iconal (eikonal), 385  
   operator, 55

**O, P**

orthogonal functions, 222  
 parabolic wave equation, 405  
 piezoelectric  
   conversion, 583  
   transducer, 624  
 plate  
   bending motion, 420  
   radiation, 422  
   simply supported, 423  
 potential  
   double layer, 301  
   single layer, 301  
 pressure, 18  
 propagation, 33, 79  
   equation of, 33, 79

**Q, R**

quadripole, 272  
 radiation  
   from a baffled disk, 327  
   from a free disk, 322

random incidence, 183  
 reciprocity, 294  
 reflection coefficient, 112, 178  
 relaxation, 56, 72  
   molecular, 56, 72  
 reverberation time, 479  
 room acoustics  
   higher frequency range, 488  
   history of, 508  
   reverberation chambers, 505  
   statistical approximation, 497  
   transient regime, 494  
 rotation, 57

**S**

Sabine's absorption, 508  
 separated variables, 177  
 shear motion, 112  
   Sommerfeld's theory, 371, 374  
 spherical  
   coordinates, 227, 245  
   harmonics, 249  
   wave reflection, 184  
 Statistical Energy Analysis (SEA),  
   461  
 string, 310  
   hammered, 312  
   plucked, 312  
 subsonic uniform flows, 547

**T**

tensor  
   strain, 57  
   stress, 62  
 temperature effects, 397  
 thermal, 19  
   operator, 56  
   phenomena, 19  
 thermoacoustics, 155  
   engine, 155  
 thermodynamics, 20, 56  
   basis of, 20  
 thermomechanics, 20, 93  
 thin plane walls, 424

transmission coefficient, 191  
transparency, 426

- circular membrane, 448
- coincidence frequency, 429
- critical frequency, 429
- mass law, 429
- modal theory, 438
- multilayered systems, 434
- rectangular plate, 444
- thick plate, 457
- to diffused fields, 431
- transmission loss, 429

tube length correction, 339

## V

velocity

- group, 202, 241, 556
- phase, 201, 240, 556
- potential, 38
- vortical, 112

viscous, 19

- operator, 55
- phenomena, 20

## W

wave, 16

- evanescent, 197, 240
- flexural (bending), 413
- flexural (in membranes), 414
- flexural (in plates), 416
- helicoidal, 244
- longitudinal, 16, 410
- propagating, 197
- propagative, 173, 240
- quasi-longitudinal, 410
- transverse shear, 412
- transverse, 16

waveguide

- circular, 238
- electroacoustic analogies, 611
- rectangular, 194

wind effects, 401